

MODEL TX700T - COLOR TFT TOUCHSCREEN OPERATOR INTERFACE

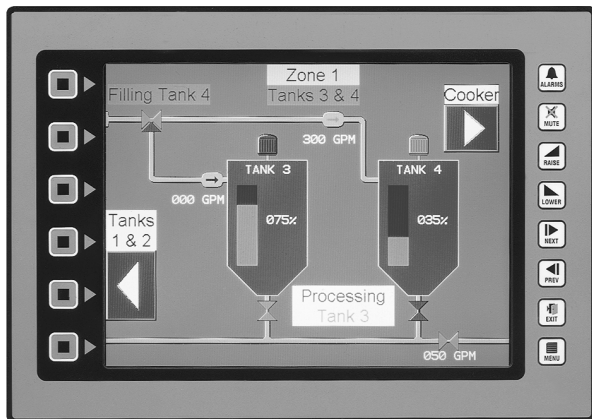

DESCRIPTION

Model TX700T Operator Terminal combines unique capabilities normally expected only from expensive SCADA packages, with dramatic ease of use. TX700T is configured using the same powerful EDICT97 Software as all Red Lion Paradigm Operator Interfaces. The results are savings in time to get challenging applications up and running, and frequent savings in hardware costs due to replacing many functions usually performed in separate expensive devices.

SAFETY SUMMARY

All safety regulations, local codes and instructions that appear in this and corresponding literature, or on equipment, must be observed to ensure personal safety and to prevent damage to either the instrument or equipment connected to it. If equipment is used in a manner not specified by the manufacturer, the protection provided by the equipment may be impaired.

Do not use this unit to directly command motors, valves, or other actuators not equipped with safeguards. To do so can be potentially harmful to persons or equipment in the event of a fault to the unit.



The protective conductor terminal is bonded to conductive parts of the equipment for safety purposes and must be connected to an external protective earthing system.



CAUTION: Risk of Danger.
 Read complete instructions prior to installation and operation of the unit.



CAUTION: Risk of electric shock.

- 10.4" BRIGHT, WIDE VIEWING ANGLE VGA COLOR DISPLAY
640 X 480 PIXELS CCFL TFT (16 colors)
- 200 X 200 CELL RESISTIVE TOUCHSCREEN
- POWERFUL 32-BIT PROCESSOR AND ACCELERATED GRAPHICS CONTROLLER FOR HIGH PERFORMANCE LEVELS
- MULTIPLE LANGUAGE SUPPORT (UP TO 8 LANGUAGES)
- ANIMATED PowerPoint® STYLE PAGE TRANSITIONS
- SLIDEOUT SOFTKEY MENUS
- 500 ALARM POINT LOGGER
- UNLIMITED PASSWORD PROTECTION
- REAL TIME CLOCK BATTERY BACKED
- FORM C RELAY OUTPUT
- EXPRESSION EVALUATION
- 32-BIT/FLOATING POINT MATH
- NEMA 4/IP65
- DIRECT NETWORK (Including Multiple Protocol) OR MODEM LINK TO PLC



UL Recognized Component,
 File # E179259

GENERAL SPECIFICATIONS

1. **POWER REQUIREMENTS:** 15 VDC to 30 VDC @ 15.25 W
 Power Up Current: 2.5 A for 4 msec max.
 Must use a Class 2 or SELV rated power supply.
2. **DISPLAY:** 640 x 480 pixels (10.4") CCFL Liquid Crystal TFT color full VGA display. Text formats up to 40 x 30 characters.
3. **KEYPAD:** 6 screen legendable soft keys, raise, lower, next, previous, exit, menu, alarms and mute keys are all embossed and have tactile feedback.
4. **TOUCHSCREEN:** Continuous resistive touch screen interface specified for up to 5 million operations. 200 X 200 touch cells.

ORDERING INFORMATION

MODEL NO.	DESCRIPTION	PART NUMBER
TX700T	640 X 480 CCFL, Full VGA Color TFT, 40 X 30, W/Touchscreen 736 K memory	TX700T00
—	EDICT-97 Development Kit. Includes Software, Manual and 9-pin RS232 Programming cables	SFEDT
—	Communication Cables	P895xxxZ
—	Battery Replacement	BAL3R004
—	Backlight Tube Replacement	Consult Factory

DIMENSIONS In inches (mm)

Tolerance: ±.010" (±0.25mm)

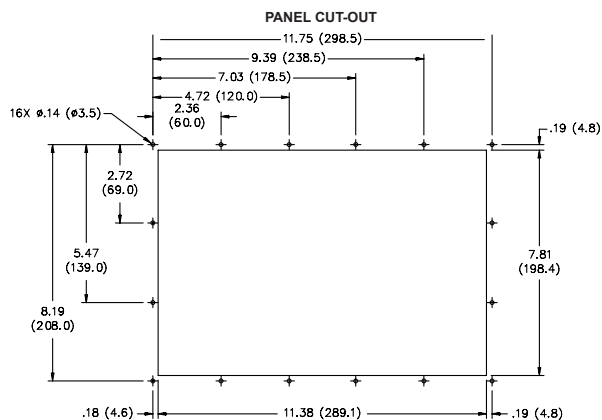
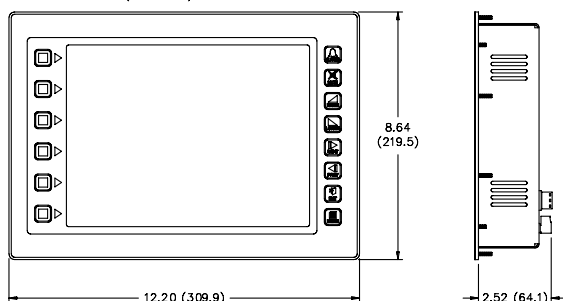

5. **MEMORY:** 736K (672k user) battery backed RAM (Battery life expectancy 3 years 50/50 on/off cycle).
6. **RELAY OUTPUT:** Form C relay output 1 A @ 120 VAC, 1 A @ 28 VDC
7. **MOUNTING REQUIREMENTS:**
Max. panel thickness is 0.375" (9.5 mm). For NEMA 4/IP65 sealing, a steel panel with a minimum thickness of 0.125" (3.175 mm) is recommended.

8. **CERTIFICATIONS AND COMPLIANCES:**

SAFETY

UL Recognized Component, File # E179259, UL61010-1, CSA 22.2 No. 61010-1 Recognized to U.S. and Canadian requirements under the Component Recognition Program of Underwriters Laboratories, Inc.

Type 4 Enclosure rating (Face only), UL50

IECEE CB Scheme Test Certificate # US/9737/UL,

CB Scheme Test Report # E179259-V01-S04

Issued by Underwriters Laboratories, Inc.

IEC 61010-1, EN 61010-1: Safety requirements for electrical equipment for measurement, control, and laboratory use, Part 1.

IP65 Enclosure rating (face only), IEC 529

ELECTROMAGNETIC COMPATIBILITY

Emissions and Immunity to EN 61326

Immunity:

Electrostatic discharge	EN 61000-4-2	Criterion A 4 kV contact discharge 8 kV air discharge
Electromagnetic RF fields	EN 61000-4-3	Criterion A 10 V/m
Fast transients (burst)	EN 61000-4-4	Criterion A 2 kV power 2 kV signal
Surge	EN 61000-4-5	Criterion A .5 kV L-L, 1 kV L&N-E power ² 1 kV signal
RF conducted interference	EN 61000-4-6	Criterion A 30 V/rms
Power frequency magnetic fields	EN 61000-4-8	Criterion A 30 A/m

Emissions:

Emissions	EN 55011	Class A
-----------	----------	---------

Notes:

1. *Criterion A: Normal operation within specified limits.*
2. *Surge; unit meets criteria A to 1 kV L-L and 2 kV L&N-E with a power line filter installed, RLC #LFIL0000 (Schaffner FN610) or equivalent.*

9. **ENVIRONMENTAL CONDITIONS:**

Operating Temperature: 0 to 40°C

Storage Temperature: -20 to 60°C

Operating and Storage Humidity: 20 to 80% max. RH (non-condensing) from 0°C to 50°C.

Altitude: Up to 2000 meters

10. **PHYSICAL DIMENSIONS:** L = 12.16" (308.5 mm), H = 8.59" (218 mm), D = 2.14" (66.8 mm).

11. **CONSTRUCTION:** Steel rear metal enclosure with NEMA 4/IP65 aluminum front plate when correctly fitted with the gasket provided. This unit is rated for NEMA 4/IP65 indoor use. Installation Category II, Pollution Degree 2

12. **WEIGHT:** 6.20 lb. (2.81 Kg.)

INPUT/OUTPUT COMMUNICATIONS SPECS

1. **SERIAL PORTS:** Data Format and Baud Rates for each port are individually software programmable up to 19200 baud.

Port 1: Programming Port - RS-232 on an RJ-11 jack.

Port 2: RS-232 Port on a Plug-In Screw Terminal Block

Port 3: RS-485 Port on a Plug-In Screw Terminal Block

(Up to 29 units can be connected and individually addressed.)

Note: LED Indicators show communications status on Ports 2 & 3

2. **COMMUNICATION MODES:** Any of the three ports can be used to communicate with Serial Devices.

Model - (TX700T) may communicate in Master mode with a different device protocol on each port (See Note & Exception).

However, only one of Ports 2 and 3 may be configured, if either is selected as a Slave protocol.

Note: Ports 2 and 3 may be configured as different device protocols in Master mode and Port 1 may be used simultaneously in Slave mode for a third device protocol.

Exception: If Allen Bradley DH485 is selected on either Port 2 or 3, only Port 1 will be available for a separate Device Protocol.

COMMON FEATURES FOR TOUCHSCREEN OPERATOR TERMINALS

PROGRAMMABILITY

Event Driven Configuration Tool

Edict 97, an extremely powerful Windows® 95/3.11 based software program, provides for the intuitive configuration of every aspect of the operator interface's behavior. The requirement for time consuming PLC ladder logic is drastically reduced by the unique event driven approach of EDICT 97. The capability of this program, in conjunction with the PLC and the Paradigm operator interface unit, ensures a great deal of advanced functionality for your system. This powerful PLC/Paradigm system provides many of the capabilities and features normally associated with the more complicated and costly PC/SCADA systems. Display pages are easily generated, including PLC and internal variables, text strings, or bar charts. All dynamic elements are also available as alarms, recipes, triggers, and reports for the run time software. After completion of the programming, the program is directly downloaded to the operator interface from your PC, without any compiling or saving requirement. When you require a change in your program, EDICT 97 loads only the change, not the entire program, saving valuable on-line time.

DYNAMIC DISPLAY PAGE ELEMENTS

Each display page has provisions to show static and dynamic information, including data variables, text messages, time, and date.

Data Variables can be either PLC derived or internally generated, either in data entry or display only mode. The Paradigm unit has an extremely powerful math capability, allowing the operator to manipulate the variables to meet the specific application's demands. If required, the display can be formatted to BCD, binary, hex, floating point, and string. Upper and lower limits of data entry variables are fully supported and password protected.

Text Message Animation enables several different types of animated text from a local or global message table to be displayed. The message displayed is dependent on the condition of the particular controlling expression. The controlling expression may be a PLC bit level, a timer value, preset counter condition, or any one of a wide variety of message triggers.

Time and Date in the Paradigm unit has the capability to display in any combination of year, month, day, hours, minutes, and seconds.

Bar Graphs in horizontal format are easily attached to data variables. The partial or full length bar graph displays can be scaled and offset to optimize the required display effect.

SECURITY

The password protection scheme provides the ultimate in tamper-proof capability. Access can be limited on a unit, page, recipe, or even individual data entries.

ALARMS

The Paradigm unit can monitor and log up to 500 alarms. Such triggers as a simple bit level transition, a PLC coil activation, or a complex application algorithm can activate an alarm. The alarms can be time and date stamped, with an automatic screen display and/or downloading to a printer for hard copy recording purposes.

RECIPE HANDLING

Recipe handling in the Paradigm Operator Interfaces can be tailored to your requirements. Using the "Data Files" section of Named Data, one can set up arrays with meaningful titles, and select, edit, and maintain, recipe data up to 8000 elements per file. In conjunction with User Programs, and the flexible data displays, the operator can select desired recipe, by number or by title, and either upload from, or download to, the target system. All the functions of EDICT97 are available, so the programmer can password protect the editing of the recipes and allow for the transfer of data from a host system.

REAL TIME SCHEDULE

Real time schedule allows for repetitive or one time tasks to take place in the system.

MULTIPLE LANGUAGE SUPPORT

This powerful feature allows users to program the text in their databases in up to 8 different languages. A system variable entry makes it easy for end users to select one of the preprogrammed languages. EDICT 97 features powerful language editing tools for easy implementation.

USER PROGRAMS

This feature offers the user the ability to incorporate custom application requirements via a powerful program language.

TOUCH KEY EDITING

All the interface keys can be programmed to perform virtually unlimited functions with each key, having multiple actions assigned to three types of key events: key pressed, key held down (auto repeat), and key released. Typical key actions would be Gotopage, set value, load recipe, view alarms, print report, and many more. TX700T keys can be defined flexibly as touch sensitive objects anywhere on a display page, or using any of the 6 screen legendable soft-keys.

COMMUNICATIONS

With over 80 communication drivers available, the Paradigm operator interface offers a wide range of connectivity, including PLCs, Variable Speed Drives, Temperature Controllers, Bar Code Readers, etc. Utilizing real PLC data references, the automatic comms configuration optimizes the system's communication performance. In the event that your specific driver does not appear on the Paradigm drivers list, let us know, as this list is always being expanded to meet our customers' needs.

COLOR GRAPHIC UNITS

In addition to all the features of the character-based units, the TX will provide exceptional value in displaying trend graphs, process schematics and flow, and others, limited only by the imagination of the designer. The programmer can use the built-in standard symbols, or construct them. A sequence of graphical symbols can be assigned to a PLC location, and the powerful software will step through the sequence without the necessity of programming multiple expressions for each bitmap. Some of the inherent features of the Graphical Display units are data logging, process symbols, such as tanks, valves, etc.

ANIMATED GRAPHICS

Graphical pages are constructed using both bitmaps and object graphics. Animation items such as trending, tank filling, horizontal and vertical bar graphs, valves, etc., make your display pages aesthetically pleasing as well as informative to the operator.

TOUCH-SCREEN

The TX700T is fitted with a continuous resolution resistive touch-screen, providing an effective resolution of over 200 by 200 cells. This allows touch-sensitive objects to be placed anywhere on the screen, without restricting your designs to the coarse grid employed by competitive products. The touch-screen is fully operable with gloved hands and is specified for up to 5 million operations.

HARDWARE INFORMATION

This bulletin contains a variety of information related to the installation and operation of the Operator Interface supplied. Ideally, you should read this document thoroughly before attempting to use the equipment. For information about the software aspects of the terminal, please consult other documentation.

CONTENTS OF PACKAGE

The Operator Interface is supplied in a packaging box containing the following...

- ◆ The interface terminal itself.
- ◆ A NEMA 4/IP65 rated mounting gasket.
- ◆ A bag containing panel hardware.
- ◆ This hardware bulletin.
- ◆ If any of these items are missing, please contact your supplier immediately.

POWER SUPPLY REQUIREMENTS

The Operator Interface requires a regulated 15 to 30 VDC power supply rated at 15.25 W or greater unless otherwise stated on the label.

- ◆ The terminal may take as little as 300 mA in certain circumstances, so be sure that the chosen power supply can operate correctly with this load. Large switch-mode supplies tend to need a certain minimum load before they will operate correctly.

In any case, it is very important that the power supply is mounted correctly if the unit is to operate reliably. A very high proportion of reported problems are caused by incorrect power supply installation, so please take care to observe the following points...

- ◆ The power supply must be mounted close to the unit, with usually not more than 6 feet of cable between the supply and the Operator Interface. Ideally, as short a length as is possible should be used.
- ◆ The wire used to connect the Operator Interface's power supply should be of at least 22 gage wire. If a longer cable run is used, you should use heavier gage wire. The routing of the cable should be kept away from large contactors, inverters and other devices which may generate significant electrical noise.

BATTERY BACKUP ISSUES

The Operator Interface is supplied with a Lithium Battery designed to maintain the internal memory and real-time clock during power outages. Assuming the operator interface terminal is powered up for 50% of the time, this battery should last over 4 years. A "Battery Low" system variable is available so that the programmer can choose specific action(s) to occur when the battery voltage drops below its nominal voltage.

It is possible to replace the battery without losing the contents of the Operator Interface's memory, but this does not reduce the importance of ensuring that a copy of the terminal's configuration is kept readily at hand to allow the terminal to be re-loaded in the case of mishaps. **Please remember that although an image of the database contents can be uploaded, this file is not editable, so the importance of keeping a copy on disk cannot be over stressed.**

CHANGING THE BATTERY

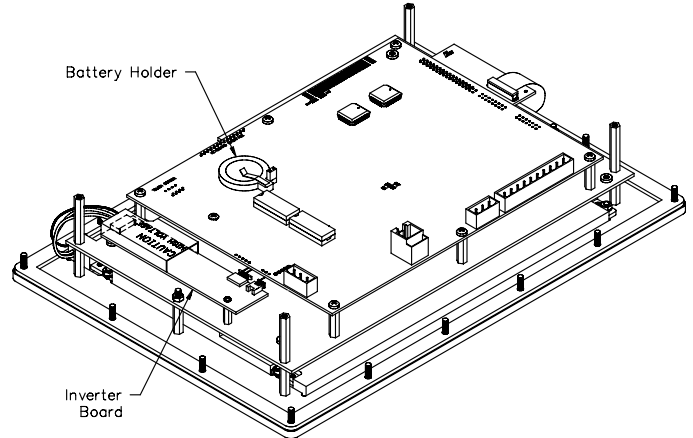

To change the internal battery, follow these steps...

- ◆ Remove the power and PLC communications connector from the unit.
- ◆ Remove the four screws from the rear cover and remove the rear cover.
- ◆ If you wish to avoid losing the terminal's configuration, reconnect the power connector and re-apply power. Note that this will require the panel to be powered-up and, as such, only suitably qualified service personnel should carry out this procedure.



CAUTION: RISK OF ELECTRIC SHOCK

The inverter board, attached to the mounting plate, supplies the high voltage to operate the backlight. Touching the inverter board may result in injury to personnel.

- ◆ The battery is located in a holder on the main circuit board. This should be clearly visible. Remove the battery from its holder.
- ◆ Place the new battery in the holder. The terminal's power supply can now be disconnected, if you re-applied power in the step above.
- ◆ Replace the lid, screws and connector by following the above procedure in reverse. You may like to make a note of the date the battery was replaced to allow planned maintenance to be carried out.
- ◆ If you did not keep the unit powered-up during battery replacement, hold down the EXIT and MUTE keys on the keyboard and cycle power to clear the internal memory. Release the keys and follow the menu guides to reset the unit. The unit is now ready for a configuration database to be reloaded.

Please note that the old battery must be disposed of in a manner which complies with your local waste regulations. Also, the battery must not be disposed of in fire or in a manner whereby it may be damaged and its contents come into contact with human skin.

INSTALLATION & CONNECTIONS

The unit meets NEMA 4/IP65 requirements for indoor use, when properly installed. The units are intended to be mounted into an enclosed panel.



The protective conductor terminal is bonded to conductive parts of the equipment for safety purposes and must be connected to an external protective earthing system.

INSTALLATION ENVIRONMENT

The unit should be installed in a location that does not exceed the maximum operating temperature and provides good air circulation. Placing the unit near devices that generate excessive heat should be avoided.

Continuous exposure to direct sunlight may accelerate the aging process of the bezel. The bezel should be cleaned only with a soft cloth and neutral soap product. Do NOT use solvents.

Do not use tools of any kind (screwdrivers, pens, pencils, etc.) to operate the keypad or touchscreen of the unit.

MOUNTING INSTRUCTIONS

The Operator Interfaces are designed for through-panel mounting. A neoprene gasket is provided, to enable sealing to NEMA 4/IP65 specification. The panel cut-out diagram for the model supplied is provided. All mounting holes should be drilled for 0.14" (3.5 mm) clearance. Care should be taken to remove any loose material from the mounting hole to avoid such material falling into the Operator Interface itself during installation.

CONNECTING TO A PLC

The Operator Interface is designed to operate with a PLC. A serial communication connection must be made between the operator interface terminal and PLC, and the details of this connection vary according to which PLC is used.

PLC TYPE

Details on how to connect to most PLCs are available on request from RLC.

CONNECTING TO AN IBM® PC/AT

The Operator Interface is programmed via software running on an IBM PC/AT or a compatible computer. The connection between the PC/AT and the operator interface terminal is made via a custom cable provided with the EDICT Development Kit. The cable is designed for a 9-pin serial port. Please contact your supplier if you require a 25-pin version.

PROGRAMMING PORT PIN OUT

The Operator Interface's programming port is sometimes used to connect other RS-232 devices, such as printers. The following illustration and table gives the pin-out of this port to enable such connections to be made.

RJ11 FEMALE	
PIN	NAME
1	RTS
2	Tx
3	GND
4	GND
5	Rx
6	CTS

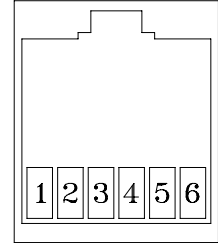

Rear View of Unit

The above table denotes the pin names of the programming port. When connecting, the pin name at the programming port is connected to the opposite of that pin name at the destination device.

TROUBLESHOOTING

For further technical assistance, contact technical support at the appropriate company numbers listed.

© 2002, RED LION CONTROLS, ALL RIGHTS RESERVED.

Information in this document is subject to change without notice and does not represent a commitment by Red Lion Controls. Software, which includes any database supplied therewith, described in this document may be furnished subject to a license agreement or a nondisclosure agreement. It is against the Law to copy the software except as specifically allowed in the license or nondisclosure agreement. No part of this document may be reproduced in any form or by any means, electronic or mechanical, including photocopying and recording, for any purpose, without the express written permission of Red Lion Controls.

PowerPoint and Windows are registered trademarks of Microsoft Corporation. Other product and company names mentioned herein may be the trademarks of their respective owners.

Disclaimer

Red Lion Controls, hereinafter referred to as RLC, will under no circumstances be responsible for direct, indirect, special, incidental or consequential damages, death or personal injury arising from the use or misuse of all or part of this documentation or the products and software described herein. Notwithstanding the above, RLC does not exclude any liability for death or personal injury caused by its negligence.

RLC does not warrant any of its software products to be free from error or to be fit for any particular purpose. Neither is the software guaranteed to provide operation without interruption. The customer's sole remedy in case of failure is the refund of the purchase price of the software.

The customer, in applying the products and software described herein, accepts that the products are wholly or partly programmable electronic systems that are inherently complex and which cannot thus be guaranteed to be free of errors. In doing so, the customer accepts the responsibility to ensure that the products are correctly programmed, configured, installed, commissioned, operated and maintained by competent and suitably trained staff and according to any instructions or safety instructions provided and as dictated by good engineering practices.

This documentation, and the software and products described herein, is subject to continuous development and improvement. All information is given in good faith, but RLC shall not be liable for any omissions or errors herein or within the software herein described.

Red Lion Controls
20 Willow Springs Circle
York PA 17402
Tel +1 (717) 767-6511
Fax +1 (717) 764-0839

Red Lion Controls BV
Basicweg 11b
NL - 3821 BR Amersfoort
Tel +31 (0) 334 723 225
Fax +31 (0) 334 893 793

Red Lion Controls AP
31, Kaki Bukit Road 3,
#06-04/05 TechLink
Singapore 417818
Tel +65 6744-6613
Fax +65 6743-3360