

ProducTVity Station™ – PLANT FLOOR COMMUNICATIONS SOLUTION



- READY TO DEPLOY PLANT FLOOR VISUALIZATION SYSTEM
- CREATES HI-DEFINITION KEY-PERFORMANCE INDICATOR AND ANDON MESSAGE BOARDS
- 720p DVI OUTPUT SUPPORTS 720 OR 1080 TVs WITH DVI OR HDMI INTERFACES
- 200+ COMMUNICATIONS DRIVERS FOR COMMUNICATING DIRECTLY WITH PLCs, DRIVES, ETC.
- SUPPORTS UP TO 16 CS-SERIES MODULES TO ACCEPT DIGITAL AND ANALOG SIGNALS
- BUILT-IN WEBSERVER ALLOWS REMOTE VIEW OR CONTROL FROM ANY INTERNET CONNECTED PC
- PROVIDES EMAIL AND SMS TEXT MESSAGE ALERTS
- INCLUDES 2GB COMPACTFLASH® CARD FOR RECORDING KPIs AND ANDON EVENTS
- SYNCs DATA LOGS TO FTP SERVERS AND MICROSOFT SQL SERVER®
- 32-BIT FLOATING POINT MATH ALLOWS CREATION OF VIRTUALLY ANY KEY PERFORMANCE INDICATOR
- INCLUDES HDMI CABLE AND HDMI/DVI ADAPTER TO SUPPORT ANY PC OR MONITOR

GENERAL DESCRIPTION

The ProducTVity Station is a ready to deploy solution for displaying productivity information, andon messaging, and process status on any off-the-shelf TV, PC monitor and even projectors. The PTV leverages over 200 communications drivers via three independent serial ports and an Ethernet port, to connect and collect data from virtually any PLC, drive, bar code scanner, etc. Its 720p (1280 x 780 resolution) DVI output is compatible with both 720p and 1080p/i TVs.

The ProducTVity Station's built-in data-logger can record any key-performance indicators, as well as andon events for later review. The PTV can synchronize the log files with any FTP server and/or Microsoft's SQL Server for further analysis.

The ProducTVity Station extends production monitoring to remote personnel by providing email and text alerts, and its built-in webservice allows productivity information to be monitored via any networked PC or smart-phone. If enabled, remote personnel can take partial or full control of the system remotely, allowing a maintenance person to effect changes without a site visit.

The ProducTVity Station ships complete with a 2GB CompactFlash card, as well as a DVI to HDMI cable (15'), and HDMI/DVI adapter. The PTV is programmed with Red Lion's popular Crimson® software.

SOFTWARE

The PTV is programmed with Crimson 3.0 software for Windows® XP Service Pack 2 or later platforms. The software is an easy to use, graphical interface which allows the configuration of communications, logging, and stunning visual displays through simple drag and drop steps.

CONTENTS OF PACKAGE

- ProducTVity Station
- Termination Plug
- Terminal Block for connecting power
- Rubber End Cap
- DVI to HDMI Cable (15')
- HDMI/DVI adapter
- 2 GB CompactFlash card

SAFETY SUMMARY

All safety related regulations, local codes and instructions that appear in the manual or on equipment must be observed to ensure personal safety and to prevent damage to either the instrument or equipment connected to it. If equipment is used in a manner not specified by the manufacturer, the protection provided by the equipment may be impaired.

Do not use the controller to directly command motors, valves, or other actuators not equipped with safeguards. To do so can be potentially harmful to persons or equipment in the event of a fault to the controller. An independent and redundant temperature limit indicator with alarm outputs is strongly recommended.

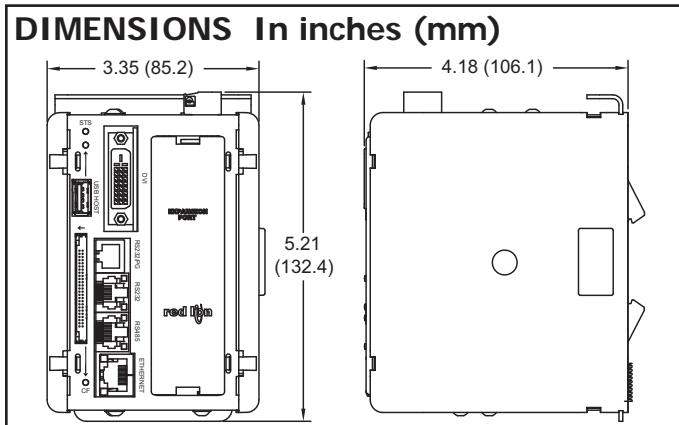
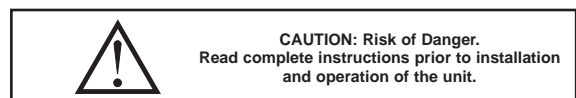

CompactFlash is a registered trademark of CompactFlash Association.

SPECIFICATIONS

- POWER:** 24 VDC \pm 10%
450 mA min. (1 module)
3.4 Amps max. (16 modules + Expansion Card)
Must use NEC Class 2 or Limited Power Source (LPS) rated power supply.
- COMMUNICATIONS:**
USB/PG Port: Adheres to USB 2.0 specification full speed only via Type B connection.



WARNING - DO NOT CONNECT OR DISCONNECT CABLES WHILE POWER IS APPLIED UNLESS AREA IS KNOWN TO BE NON-HAZARDOUS. USB PORT IS FOR SYSTEM SET-UP AND DIAGNOSTICS AND IS NOT INTENDED FOR PERMANENT CONNECTION.

USB Host Port: Complies with Universal Serial Bus Specification Rev 2.0. Support data transfers at full-speed. Hardware over current protected (0.5 A max).

DVI Port: Digital Visual Interface version 1.3, single link, provides a digital video feed, with a resolution of 1280 horizontal x 720 vertical pixels, progressive scan, adhering to CEA-861-E (720 p). DDC support, HDCP is not supported. Color depth is 32 K.

Serial Ports: Format and Baud Rates for each port are individually software programmable. Serial ports are individually isolated.

Communication port to port 1500 VAC
Communication ports to power 1000 VDC
Communication ports to earth 1000 VDC

Note: PTV dielectric withstand test per 1 minute. Communication ports: RS232/PG, RS232 port, RS485 port, Ethernet port and option cards.

RS232/PG Port: RS232 port via RJ12

COMMS Ports: RS422/485 port via RJ45, and RS232 port via RJ12

DH485 TXEN: Transmit enable; open collector. $V_{OH} = 15$ VDC, $V_{OL} = 0.5$ V @ 25 mA max.

Ethernet Port: 10 BASE-T / 100 BASE-TX

RJ45 jack is wired as a NIC (Network Interface Card). The jack shield is electrically connected to Earth ground, but the port is isolated.

3. LEDs:

STS – Status LED indicates condition of master.
USB HOST – HOST LED indicates port status/activity.
TX/RX – Transmit/Receive LEDs show serial activity.
Ethernet – Link and activity LEDs.
CF – CompactFlash LED indicates card status and read/write activity

4. MEMORY:

On-board User Memory: 128 Mbytes of non-volatile Flash memory.
On-board RAM: 64 Mbytes
Memory Card: CompactFlash Type II slot for Type I and Type II cards.

- REAL-TIME CLOCK:** Typical accuracy is less than one minute per month drift. Crimson's SNTP facility allows synchronization with external servers.
Battery: Lithium Coin Cell. Typical lifetime of 10 years at 25 °C.

A "Battery Low" system variable is available so that the programmer can choose specific action(s) to occur when the battery voltage drops below its nominal voltage.

This unit is NOT field serviceable. All work must be done by a qualified technician.

6. ENVIRONMENTAL CONDITIONS:

Operating Temperature Range: 0 to 45°C
Storage Temperature Range: -30 to +70°C
Operating and Storage Humidity: 80% max relative humidity, non-condensing, from 0 to 50°C
Altitude: Up to 2000 meters

- CONSTRUCTION:** Case body is black high impact plastic and stainless steel. For indoor use only. Installation Category II, Pollution Degree 2.
- POWER CONNECTION:** Removable wire clamp screw terminal block.
Wire Gage Capacity: 24 AWG to 12 AWG
Torque: 4.45 to 5.34 in/lb (0.5 to 0.6 N-m)
- MOUNTING:** Snaps onto standard DIN style top hat (T) profile mounting rails according to EN50022 -35 x 7.5 and -35 x 15.

10. CERTIFICATIONS AND COMPLIANCES:

SAFETY

Check each module's specifications to determine system compliance.

IEC 61010-1, EN 61010-1: Safety requirements for electrical equipment for measurement, control, and laboratory use, Part 1.

ELECTROMAGNETIC COMPATIBILITY

Emissions and Immunity to EN 61326: 2006: Electrical Equipment for Measurement, Control and Laboratory use.

Immunity to Industrial Locations:

Electrostatic discharge	EN 61000-4-2	Criterion B 4kV contact discharge 8kV air discharge
Electromagnetic RF fields	EN 61000-4-3	Criterion A ³ 10V/m (80 MHz to 1 GHz) 3 V/m (1.4 GHz to 2 GHz) 1 V/m (2 GHz to 2.7 GHz)
Fast transients (burst)	EN 61000-4-4	Criterion B power 2kV I/O signal 1kV I/O signal connected to power 2kV
Surge	EN 61000-4-5	Criterion B power 1 kV L to L, 2 kV L to G signal 1 kV
RF conducted interference	EN 61000-4-6	Criterion A 3 Vrms

Emissions:

Emissions EN55011 Class A

Notes:

- Criterion A: Normal operation within specified limits.*
- Criterion B: Temporary loss of performance from which the unit self-recovers.*
- Certain modules with analog input and/or output signals may have their signals deviate during disturbance but self-recover when disturbance is removed (refer to individual modules for details).*

- WEIGHT:** 1.313 lb (596 g)

HARDWARE INSTALLATION

DIN rail should be mounted horizontally so that the unit's ventilation holes are vertical in relation to cabinet orientation. A minimum clearance of 1 inch (25.4 mm) should be maintained above and below the unit in order to ensure proper thermal regulation. A minimum top clearance of 3.00 inch is needed when using the USB/PG port.

The unit shall be installed inside a UL Listed Industrial Control Panel or similar type of enclosure. A minimum 3.2 mm distance shall be maintained between the hazardous live parts of the equipment and accessible parts of the fire/electrical enclosure.

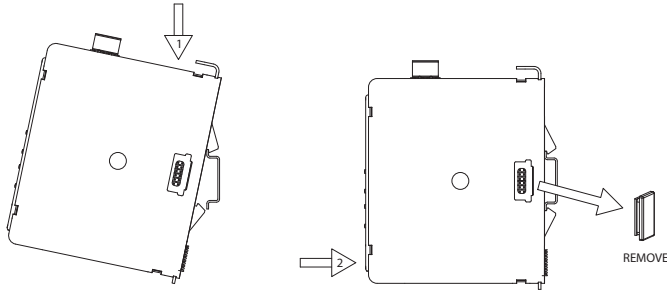

Figure 1 - Attach PTV Station To DIN Rail and Remove Rubber End Cap

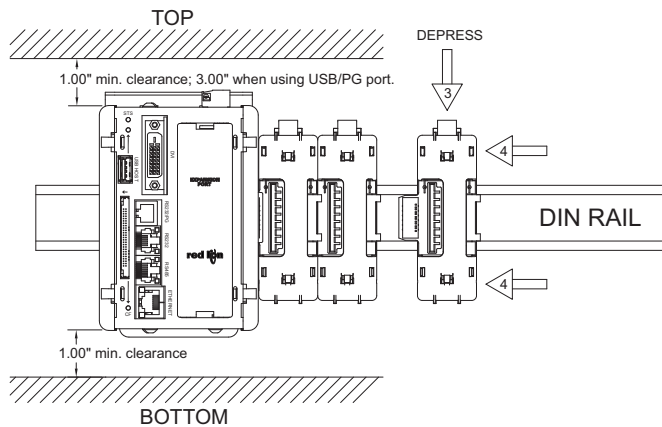

Figure 2 - Attach Slave Bases To DIN Rail

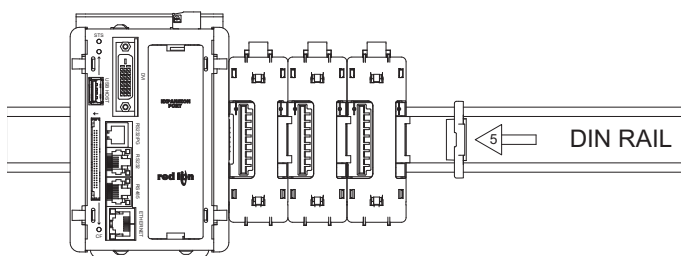

Figure 3 - Attach Termination Plug*
* Supplied with PTV Station.

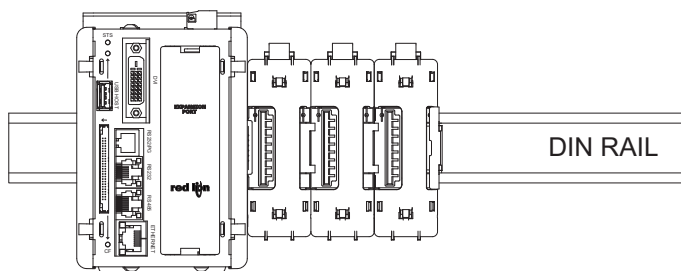
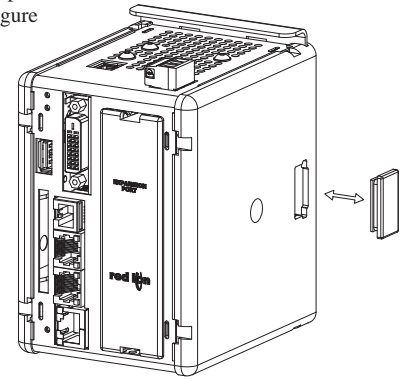

Figure 4 - Installation Complete

PROTOCOL CONVERSION

Mount the PTV as shown under Hardware Installation Figure 1 above. Install the rubber end cap. The end cap protects the pins from damage. Configure the PTV for zero modules.



POWER SUPPLY REQUIREMENTS

It is very important that the power supply is mounted correctly if the unit is to operate reliably. Please take care to observe the following points:

- The power supply must be mounted close to the unit, with usually not more than 6 feet (1.8 m) of cable between the supply and the master. Ideally, the shortest length possible should be used.
- The wire used to connect the PTV's power supply should be at least 22-gage wire. If a longer cable run is used, a heavier gage wire should be used. The routing of the cable should be kept away from large contactors, inverters, and other devices which may generate significant electrical noise.
- A power supply with an NEC Class 2 or Limited Power Source (LPS) and SELV rating is to be used. This type of power supply provides isolation to accessible circuits from hazardous voltage levels generated by a mains power supply due to single faults. SELV is an acronym for "safety extra-low voltage." Safety extra-low voltage circuits shall exhibit voltages safe to touch both under normal operating conditions and after a single fault, such as a breakdown of a layer of basic insulation or after the failure of a single component has occurred.

Visit www.redlion.net for a complete list of our PSDR Series of NEC Class 2 power supplies.

EMC INSTALLATION GUIDELINES

Although Red Lion Controls Products are designed with a high degree of immunity to Electromagnetic Interference (EMI), proper installation and wiring methods must be followed to ensure compatibility in each application. The type of the electrical noise, source or coupling method into a unit may be different for various installations. Cable length, routing, and shield termination are very important and can mean the difference between a successful or troublesome installation. Listed are some EMI guidelines for a successful installation in an industrial environment.

1. To reduce the chance of noise spikes entering the unit via the power lines, connections should be made to a clean source. Connecting to circuits that also power loads such as contactors, relays, motors, solenoids etc. should be avoided.
2. The unit should be mounted in a metal enclosure, which is properly connected to protective earth.
3. Use shielded (screened) cables for all Signal and Control inputs. The shield (screen) pigtail connection should be made as short as possible. The connection point for the shield depends somewhat upon the application. Listed below are the recommended methods of connecting the shield, in order of their effectiveness.
 - a. Connect the shield to earth ground (protective earth) at one end where the unit is mounted.
 - b. Connect the shield to earth ground at both ends of the cable, usually when the noise source frequency is over 1 MHz.
 - c. Connect the shield to common of the master and leave the other end of the shield unconnected and insulated from earth ground.
4. Never run Signal or Control cables in the same conduit or raceway with AC power lines, conductors feeding motors, solenoids, SCR controls, and heaters, etc. The cables should be run through metal conduit that is properly grounded. This is especially useful in applications where cable runs are long and portable two-way radios are used in close proximity or if the installation is near a commercial radio transmitter. Also, Signal or Control cables within an enclosure should be routed as far away as possible from contactors, control relays, transformers, and other noisy components.

5. Long cable runs are more susceptible to EMI pickup than short cable runs. Therefore, keep cable runs as short as possible.
6. In extremely high EMI environments, the use of external EMI suppression devices is effective. The following EMI suppression devices (or equivalent) are recommended:

Ferrite Suppression Cores for signal and control cables:

- Fair-Rite part number 0443167251 (RLC part number FCOR0000)
- TDK part number ZCAT3035-1330A
- Steward part number 28B2029-0A0

Line Filters for input power cables:

- Schaffner part number FN2010-1/07 (RLC part number LFIL0000)
- Schaffner part number FN670-1.8/07
- Corcom part number 1 VR3

Visit RLC's web site at www.redlion.net for more information on EMI guidelines, Safety and CE issues as they relate to Red Lion Controls products.

WIRING

POWER CONNECTION

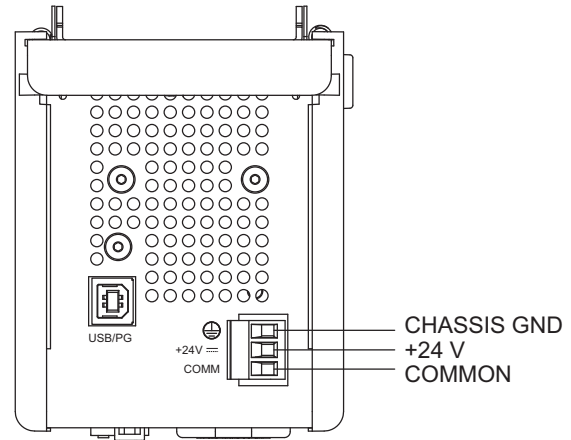

PROGRAMMING PORTS

RS232/PG

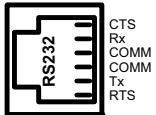

USB/PG



ETHERNET

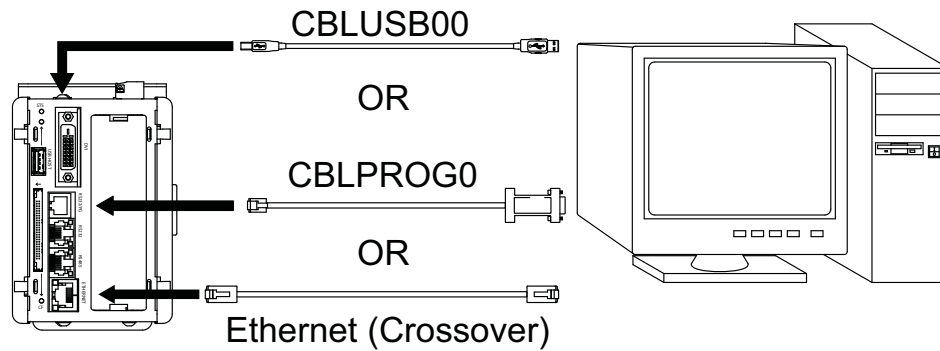

COMMUNICATION PORTS

RS232/PG

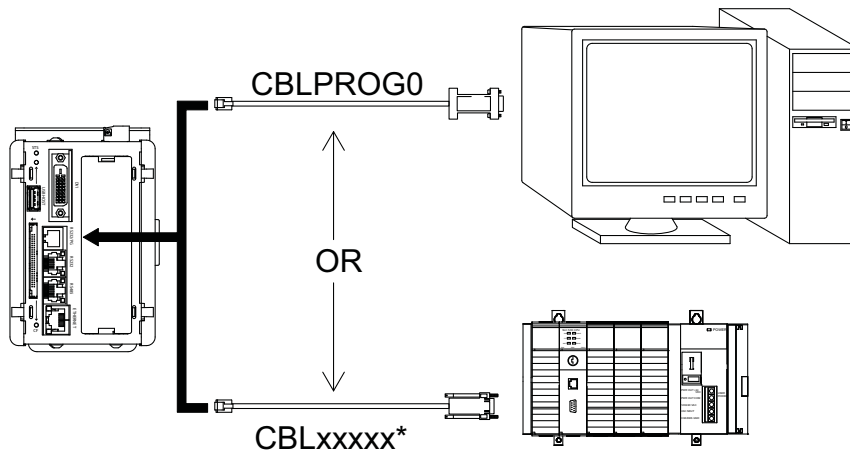
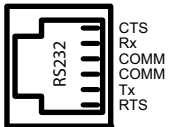

RS232

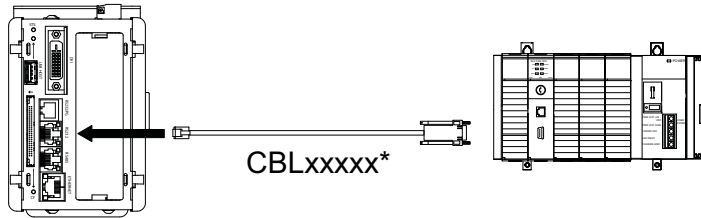
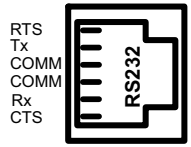

* Use appropriate communications cable. See Ordering Information for descriptions of the available cables.

RS485

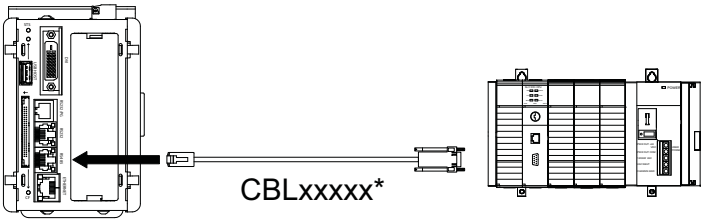
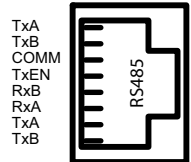

WARNING: Do **NOT** use a standard DH-485 cable to connect this port to Allen Bradley equipment.

ETHERNET CONNECTION

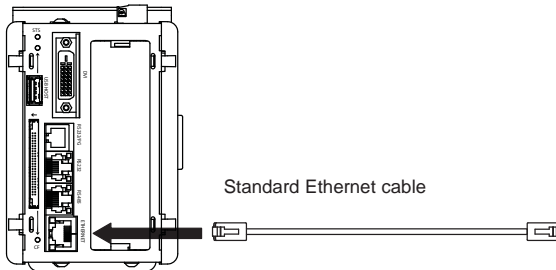

DVI PORT CONNECTION

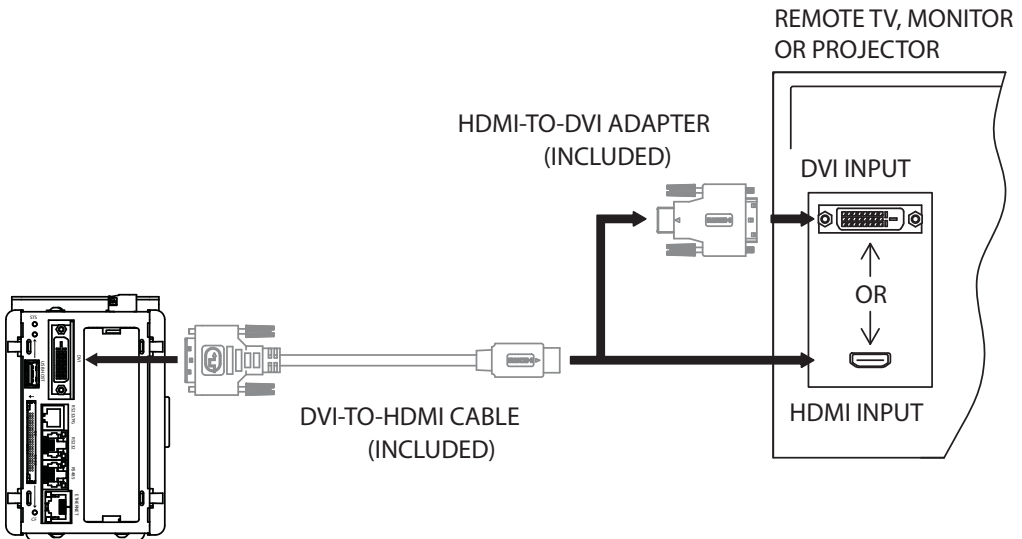
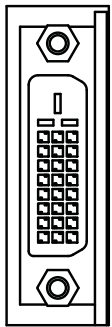

PTV PORT PIN OUTS

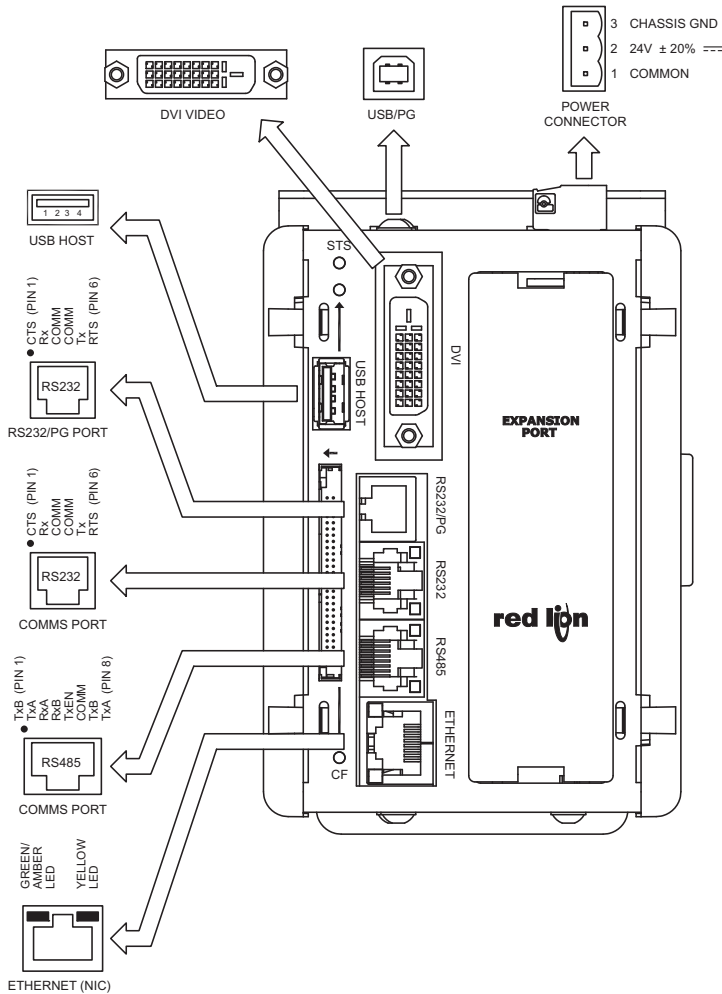

TROUBLESHOOTING

If for any reason you have trouble operating, connecting, or simply have questions concerning your new PTV, contact Red Lion's technical support. For contact information, refer to the back page of this bulletin for phone and fax numbers.

EMAIL: techsupport@redlion.net
 Web Site: <http://www.redlion.net>

COMMUNICATING WITH THE PTV STATION

CONFIGURING A PTV

The PTV is configured using Crimson software. Crimson is available as a free download from Red Lion's website. Updates to Crimson for new features and drivers are posted on the website as they become available. By configuring the PTV using the latest version of Crimson, you are assured that your unit has the most up to date feature set. Crimson software can configure the PTV through the RS232/PG port, USB/PG port, Ethernet or CompactFlash. The USB/PG port is connected using a standard USB cable with a Type B connector.

The driver needed to use the USB port will be installed with Crimson. The RS232/PG port uses a programming cable made by Red Lion to connect to the DB9 COM port of your computer. If making your own cable, refer to the "PTV Port Pin Outs" for wiring information.

The CompactFlash can be used to program a PTV by placing a configuration file and firmware on the CompactFlash card. The card is then inserted into the target PTV and powered. Refer to the Crimson literature for more information on the proper names and locations of the files.

CABLES AND DRIVERS

Red Lion has a wide range of cables and drivers for use with many different communication types. A list of these drivers and cables along with pin outs is available from Red Lion's website. New cables and drivers are added on a regular basis. If making your own cable, refer to the "PTV Port Pin Outs" for wiring information.

USB, DATA TRANSFERS FROM THE COMPACTFLASH CARD



WARNING - USB PORT IS FOR SYSTEM SET-UP AND DIAGNOSTICS AND IS NOT INTENDED FOR PERMANENT CONNECTION.

In order to transfer data from the CompactFlash card via the USB port, a driver must be installed on your computer. This driver is installed with Crimson and is located in the folder C:\Program Files\Red Lion Controls\Crimson x.x\Device\ after Crimson is installed. This may have already been accomplished if your PTV was configured using the USB port.

Once the driver is installed, connect the PTV to your PC with a USB cable, and follow "Mounting the CompactFlash" instructions in the Crimson user manual.

Note that using the USB port for frequent data transfers is not recommended. For frequent data transfers it is recommended that the Ethernet connection be used. Through the Ethernet connection a web page can be set up to view logged data. Refer to the Crimson manual for details.

Note: The USB port is for system set-up and diagnostics and is not intended for permanent connection.

ETHERNET COMMUNICATIONS

Ethernet communications can be established at either 10 BASE-T or 100 BASE-TX. The PTV's RJ45 jack is wired as a NIC (Network Interface Card). For example, when wiring to a hub or switch use a straight-through cable, but when connecting to another NIC use a crossover cable.

The Crimson manual contains additional information on Ethernet communications.

RS232 PORTS

The PTV has two RS232 ports. There is the RS232/PG port and the COMMS port. Although only one of these ports can be used for programming, both ports can be used for communications with a PLC. The RS232/PG port can be used for either master or slave protocols.

RS422/485 PORT

The PTV has one RS422/485 port. This port can be configured to act as either RS422 or RS485.

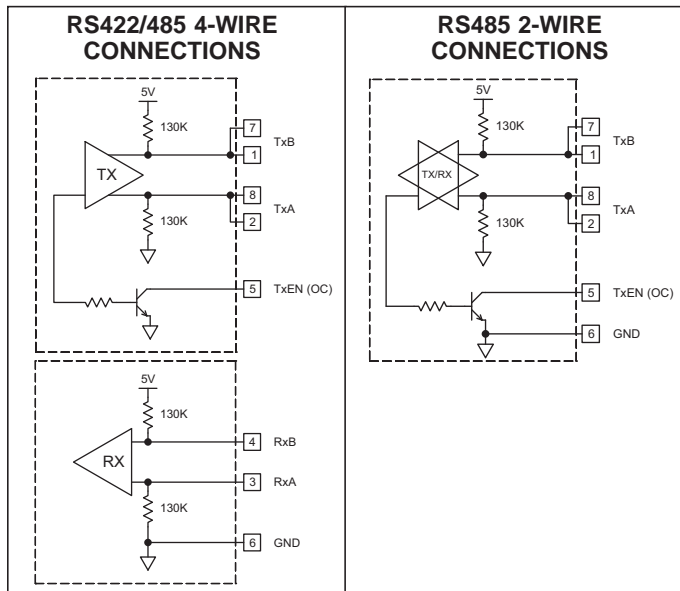

Note: All Red Lion devices connect A to A and B to B. Refer to www.redlion.net for additional information.

DH485 COMMUNICATIONS

The PTV's RS422/485 COMMS port can also be used for Allen Bradley DH485 communications.

WARNING: DO NOT use a standard DH485 cable to connect this port to Allen Bradley equipment. A cable and wiring diagram are available from Red Lion.

LEDS

STS – STATUS LED

The green Status LED provides information regarding the state of the PTV, as well as the rest of the system. This includes indication of the various stages of the start-up routine (power-up), and any errors that may occur.

Startup Routine

LED	INDICATION
Rapidly Flashing	PTV is currently running the boot loader and/or being flash upgraded by Crimson.
Steady	PTV is operating properly.

Error States

LED	INDICATION
1 blink, pause, repeat	One or more slave modules are missing from the system. PTV and installed modules will perform normally in this state.
2 blinks, pause, repeat	Missing configuration, or configuration being updated by Crimson.
3 blinks, pause, repeat	Quantity of module bases does not match configuration file. PTV will not communicate with the modules until the error is corrected.
4 blinks, pause, repeat	Termination plug not installed, or one or more bases are malfunctioning. PTV will not communicate with the modules until the plug is reinstalled, and power is cycled.

CF LED

LED	INDICATION
Off	No CompactFlash Card is present.
Steady	Valid CompactFlash card is present.
Flashing Rapidly	CompactFlash card is being checked.
Flickering	Unit is writing to the CompactFlash, either because it is storing data, or because the PC connected via the USB port has locked the drive. ¹
Flashing Slowly	Incorrectly formatted CompactFlash card present.

1. Do not turn off power to the unit while this light is flickering. The unit writes data in two minute intervals. Later Microsoft operating systems will not lock the drive unless they need to write data; Windows 98 may lock the drive any time it is mounted, thereby interfering with logging. Refer to "Mounting the CompactFlash" in the Crimson User Manual.

USER COMMUNICATION PORTS - TX/RX LEDS

LED	INDICATION
GREEN	Transmitting
RED	Receiving

Note: LEDs are not available on the Programming Port: RS232/PG.

ETHERNET LEDS

LED	INDICATION
YELLOW (Solid)	Link Established
YELLOW (Flashing)	Network Activity
GREEN	10 BASE-T Communications
AMBER	100 BASE-TX Communications

COMPACTFLASH® CARD

CompactFlash socket is a Type II socket that can accept either Type I or II cards. Use cards with a minimum of 4 Mbytes and a maximum of 2 Gbytes with the PTV's CompactFlash socket. Cards are available at most computer and office supply retailers. CompactFlash can be used for configuration transfers, data logging, and trending.

Information stored on a CompactFlash card can be read by a card reader attached to a PC. This information is stored in IBM (Windows®) PC compatible FAT16 file format.

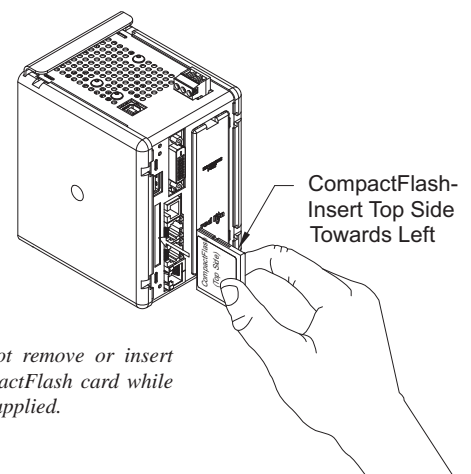

Note: Do not remove or insert the CompactFlash card while power is applied.

NOTE

For reliable operation of this and other Red Lion products, one of the following brands of CompactFlash card must be used...

SimpleTech SMART® Modular
SanDisk® Silicon Systems

Not all of the above manufacturers offer CompactFlash cards recognized to UL standards, which may be required for your application.

ORDERING INFORMATION

TYPE	MODEL NO.	DESCRIPTION	PART NUMBER
ProductVity Station	PTV ¹	Plant Floor Communications Solution	PTV00000
Communications Cables (10 feet)	CBL	RS232 Programming Cable	CBLPROG0
		USB Cable	CBLUSB00
		Communications Cables ²	CBLxxxx
Video Cable (15 feet)	CBL	DVI-to-HDMI cable w/HDMI-to-DVI adaptor (Included in PTV00000)	CBLVID00
Power Supply	PSDR	DIN Rail Mounted Power Supply	PSDRxxxx
Accessories	XCCN	CANopen option card for ProductVity Station, Modular Controller or Data Station Plus	XCCN0000
	XCDN	DeviceNet option card for ProductVity Station, Modular Controller or Data Station Plus	XCDN0000
	XCENET	Ethernet option card for ProductVity Station, Modular Controller or Data Station Plus	XCENET00
	XCGSM	GSM Cellular option card for ProductVity Station, Modular Controller or Data Station Plus	XCGSM000
	XCPB	PROFIBUS option card for ProductVity Station, Modular Controller or Data Station Plus	XCPBDP00
	XCRS	RS232/485 option card for ProductVity Station, Modular Controller or Data Station Plus	XCRS0000
	G3CF	CompactFlash Card ³	G3CFxxxx
		Rail Stops (Qty 2)	RSRSTP00
		Replacement Base	CSBASE00
		Replacement Termination Plug	CSTERM00
	Replacement Rubber End Cap	CSBUNG00	

Notes:

¹ For a complete list of PID modules & data acquisition modules, go to www.redlion.net/link/wp.asp?ID=6162.

² For a complete list of communications drivers and cables, go to www.redlion.net/link/wp.asp?ID=6163.

³ Industrial grade two million write cycles. SMART Modular Technologies model SG9CF (UL Listed Directory Category NWGQ).

LIMITED WARRANTY

The Company warrants the products it manufactures against defects in materials and workmanship for a period limited to two years from the date of shipment, provided the products have been stored, handled, installed, and used under proper conditions. The Company's liability under this limited warranty shall extend only to the repair or replacement of a defective product, at The Company's option. The Company disclaims all liability for any affirmation, promise or representation with respect to the products.

The customer agrees to hold Red Lion Controls harmless from, defend, and indemnify RLC against damages, claims, and expenses arising out of subsequent sales of RLC products or products containing components manufactured by RLC and based upon personal injuries, deaths, property damage, lost profits, and other matters which Buyer, its employees, or sub-contractors are or may be to any extent liable, including without limitation penalties imposed by the Consumer Product Safety Act (P.L. 92-573) and liability imposed upon any person pursuant to the Magnuson-Moss Warranty Act (P.L. 93-637), as now in effect or as amended hereafter.

No warranties expressed or implied are created with respect to The Company's products except those expressly contained herein. The Customer acknowledges the disclaimers and limitations contained herein and relies on no other warranties or affirmations.

Red Lion Controls
Headquarters
20 Willow Springs Circle
York PA 17406
Tel +1 (717) 767-6511
Fax +1 (717) 764-0839

Red Lion Controls
Europe
Printerweg 10
NL - 3821 AD Amersfoort
Tel +31 (0) 334 723 225
Fax +31 (0) 334 893 793

Red Lion Controls
India
54, Vishvas Tenement
GST Road, New Ranip,
Ahmedabad-382480 Gujarat, India
Tel +91 987 954 0503
Fax +91 79 275 31 350

Red Lion Controls
China
Unit 101, XinAn Plaza
Building 13, No.99 Tianzhou Road
ShangHai, P.R. China 200223
Tel +86 21 6113-3688
Fax +86 21 6113-3683