



# APPLICATION SOLUTION **PAXP #01**

## **ASPHALT MANUFACTURING AMPS MONITORING APPLICATION**

Heated silos are utilized at an asphalt manufacturing plant to store the required asphalt for the following day's state, local, or private asphalt projects. If necessary, 24 hour manufacturing may be required to maintain the 200 ton and 300 ton silos to full capacity. Less wear on the silos is realized when silos are full. When a truck is positioned beneath the silo and filled, the asphalt falls from the middle of the silo because of the coned shape. Since the asphalt falls from the sides into the middle, it does not slide down the sides, which would create wear of the steel silo, thus extending the life of the silo. To replenish the silo, a long conveyor is used to carry the asphalt from the manufacturing process to the top of the silo 50 feet high. Previously, an operator monitored the current draw of the motor driving the conveyor. If he noticed the current draw increased to a specific maximum, indicating a binding on the conveyor had occurred, he would pause the manufacturing process to free the binding. The problem with this method is when the operator needs to be away from his station performing other duties and a conveyor motor binds up, damage was done to the motor because the bind in the conveyor was not recognized.

### **PRODUCTS USED: PAXP0000, PAXCDS10, CTL0502F**

The solution is the Red Lion Controls PAXP Process Input Panel Meter and the PAXCDS10 Dual Relay Setpoint Card. The CTL0502F 50 A /4-20 mA Fixed Case Current Transformer is chosen because the distance from the CT to the meter is 100 feet and this CT can be powered by the PAXP.



### **HOW IT WORKS**

The PAXP is scaled to display motor current draw in amps. A field installable dual setpoint card, PAXCDS10, is added to the PAXP and the setpoints are configured to trigger relay outputs for a warning buzzer and a complete process shut down if the binding problem is not corrected. Normal current load of the conveyor system is around 30 amps. A warning buzzer setpoint is programmed if the current draw exceeds 45 amps. The output will reset automatically as the current decreases as a result of the bind freeing it or the operator responding to the alarm and correcting the problem. A 5 amp hysteresis can be used which results in the buzzer being triggered at 45 amps and automatically turning off if the current decreases below 40 amps. If the binding problem did not correct itself or the operator was tending to other duties, the current draw would increase to the system shut down setpoint of 65 amps, and the system would automatically shut down, saving costly motor repairs. The system shut down setpoint is configured to latch and is only reset manually after the problem is corrected. A momentary set of contacts may be used to unlatch the relay or a front panel button may be configured to release the latched relay.

## DESIGN ADVANTAGES

Setpoint levels were selected to protect equipment and allow enough time for the operator to respond to the advance warning of impending problems. The operator may now perform other duties away from the system without the constant interruptions he previously experienced while conducting visual monitoring.

## DIP SWITCH OR JUMPER SETTINGS

All are at factory settings.

## PROGRAMMING (Only non-factory settings shown)

### Pro 1-INP

INP 1 : 4.000

dSP 1 : 0

INP 2 : 20.000

dSP 2 : 100 (reading for 20 mA input)

### Pro 2-FNC

USr-1 : PLoC

USt-2 : r-2 (reset latched SP2 remote)

rSt : r-2 (reset latched SP2 front button)

### Pro 6-SPt

SPSEL : SP-1

Act-1 : AU-HI

SP-1 : 45

HyS-1 : 5

rSt-1 : Auto (auto turn of alarm)

SPSEL : SP-2

Act-2 : AU-HI

SP-2 : 65

rSt-2 : LAtC2 (latch shut down)

## WIRING DIAGRAM

All wiring must be according to the installation guidelines listed in the product's specifications. For the setpoint outputs to function an external isolated voltage source (not shown below) must be connected in series.

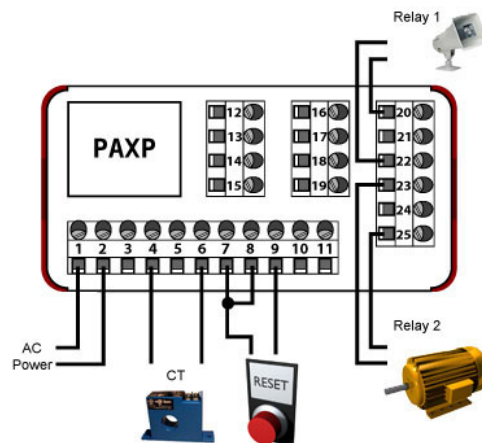

This application note is intended to be an example. Your specific application may require changes in products, programming and/or wiring. For specific assistance, you may contact your local Red Lion products supplier or Red Lion Controls Technical Support at 717-767-6511.