

Mitsubishi A/Q Series TCP/IP Master Driver

Information Sheet for Crimson v2.0

Compatible Devices

Mitsubishi A* or Q series PLC fitted with appropriate Ethernet communications module.

Verified Device

Mitsubishi Q02H CPU via QJ71E71-100 Module
Mitsubishi A3A CPU via AJ71E71N-B2 *

Supported Communication Modes

Only Binary Code communications are supported.

Accessible Data

Prefix	Description	Access
X	Input	Read / Write
Y	Output	Read / Write
M	Internal Relay	Read / Write
F	Annunciator	Read / Write
B	Link Relay	Read / Write
D	Data Register	Read / Write
W	Link Register	Read / Write
T	Timer Current Value	Read / Write
C	Counter Current Value	Read / Write

Cable Information

Standard 10-Base-T Ethernet Cable

* Note: Some compatible devices require a ladder program in order to achieve successful Ethernet communications. Sample programs can be found on the following page.

Sample Ladder Program (MELSEC – A Series)

Initial Processing

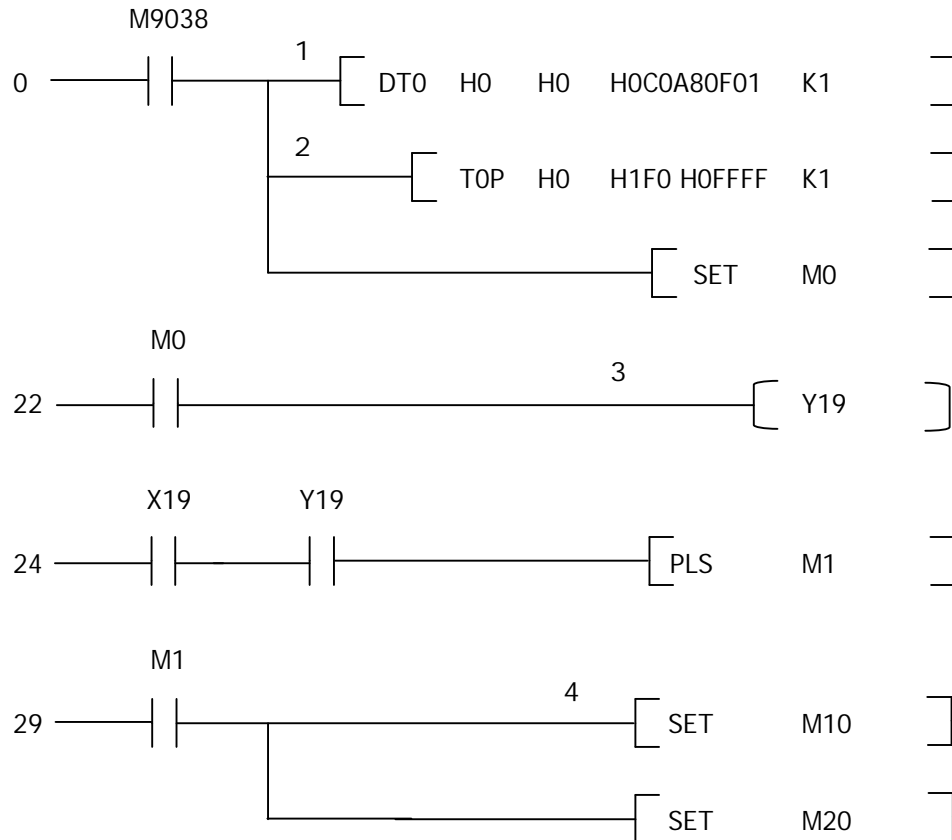

- 1) Set the IP Address to “192.168.15.1”
- 2) Enable Communication Instruction during STOP for all connections.
- 3) Turn on Initial Request signal.
- 4) After Initial Complete signal, set the TCP/IP port to WAIT-OPEN.

Sample Ladder Program (MELSEC – A Series) continued

TCP/IP Open Processing

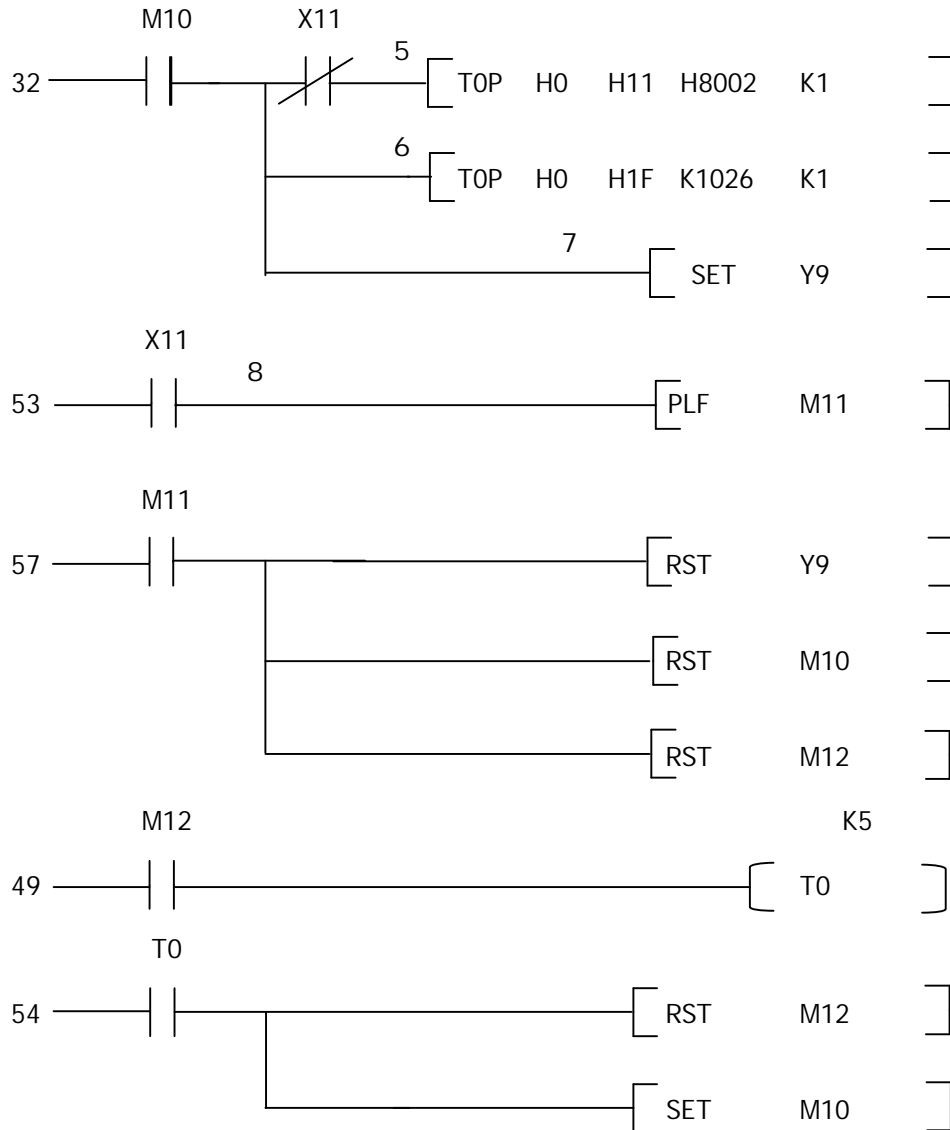

- 5) Set Connection 1 protocol.
- 6) Set Connection 1 local port.
- 7) Turn on Open Request.
- 8) When Open Complete signal turns off, turn Open Request off once and repeat step 7 after 0.5 seconds.