

## Model G15 - Graphite® Series 15" Color Touchscreen Operator Interface Terminal Installation Guide



FOR USE IN HAZARDOUS LOCATIONS:  
 Class I, Division 2, Groups A, B, C, and D  
 Class II, Division 2, Groups F and G  
 Class III, Division 2  
 T4



II 3 G Ex ic nA IIC T4 Gc  
 II 3 D Ex tc IIIC T135°C Dc  
 -20°C ≤ T<sub>AMB</sub> ≤ 60°C  
 DEMKO 14 ATEX 1387X  
 IECEx UL 15.0035X  
 UL22UKEX2574X

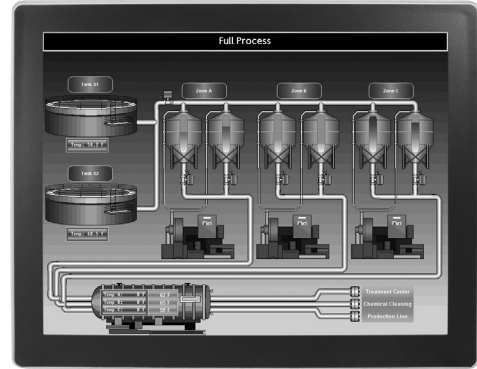
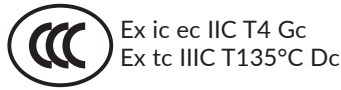

See the Red Lion website at [www.redlion.net](http://www.redlion.net) for full user manual, Crimson® software and software manual.



**WARNING - EXPLOSION HAZARD** - Substitution of components may impair suitability for Class I, Division 2

### SAFETY SUMMARY

All safety related regulations, local codes and instructions that appear in this document or on equipment must be observed to ensure personal safety and to prevent damage to either the device or equipment connected to it.

Do not use these products to replace proper safety interlocking. No software-based device (or any other solid-state device) should ever be designed to be responsible for the maintenance of personnel safety or consequential equipment not equipped with safeguards. Red Lion disclaims any responsibility for damages, either direct or consequential, that result from the use of this equipment in a manner not specified.

**CAUTION: Risk of Danger.**  
 Read complete instructions prior to installation and operation of the unit.

**WARNING - EXPLOSION HAZARD** - Do not disconnect equipment unless power has been switched off or area is known to be non-hazardous.

### ORDERING INFORMATION

DESCRIPTION	PART NUMBER
15" Color Touch Screen, Indoor Use	G15C0000
15" Color Touch Screen, Indoor Use, Additional Ethernet and Serial Port	G15C1100

### SPECIFICATIONS

#### POWER:

Input Voltage	10V	24V	30V
Typical Power HMI only:	18 W	18 W	18 W
Maximum Power HMI only:	23 W	24 W	24 W
Available Power for Modules:	33W		
Max Power HMI with Module(s):	56 W	58 W	58W

Must use a Class 2 circuit according to National Electrical Code (NEC), NFPA-70 or Canadian Electrical Code (CEC), Part I, C22.1

### DIMENSIONS In inches (mm)

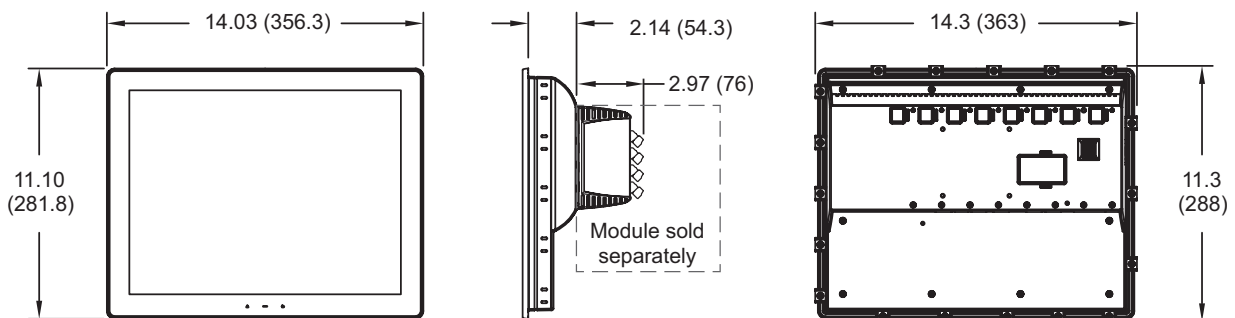

or a Limited Power Supply (LPS) according to IEC/EN 60950-1 or Limited-energy circuit according to IEC/EN 61010-1.

Power connection via removable three position terminal block.

**ENVIRONMENTAL CONDITIONS:**

Operating Temperature Range: -20 to 60 °C T<sub>AMB</sub>, or lowest range among equipment used in your Graphite system.

Consult the user manual or [www.redlion.net/Optemp](http://www.redlion.net/Optemp) for further details.

Storage Temperature Range: -20 to 70 °C T<sub>AMB</sub>

Vibration to IEC 68-2-6: Operational 5-500 Hz, 4 g

Shock to IEC 68-2-27: Operational 40 g (10 g, modules w/ relays)

Operating and Storage Humidity: 0 to 85% max. RH non-condensing

Altitude: Up to 2000 meters

Installation Category II, Pollution Degree 2 as defined in IEC/EN 60664-1.

**CERTIFICATIONS AND COMPLIANCES:**

CE Approved

EN 61326-1 Immunity to Industrial Locations

Emission CISPR 11 Class A

IEC/EN 61010-1

RoHS Compliant

ATEX Approved

⊕ II 3 G Ex ic nA IIC T4 Gc

⊕ II 3 D Ex tc IIIC T135°C Dc

DEMKO 14 ATEX 1387X

EN 60079-0, -11, -15, -31

IECEX Approved

Ex ic nA IIC T4 Gc

Ex tc IIIC T135°C Dc

IECEX UL 15.0035X

IEC 60079-0, -11, -15, -31

UKEX Approved

UL22UKEX2574X

CCC Approved

These products have obtained CCC certification and meet

the requirements of GB/T3836.1-2021, GB/T3836.3-2021, GB/T3836.4-2021, and GB/T3836.31-2021

UL Listed: File #E302106

UL Hazardous: File #E317425

Type 4X Indoor / IP66 Enclosure rating (Face only) for all models

IP20 Enclosure rating (Rear of unit)

**ABS Type Approval for Shipboard Applications**

**CONNECTIONS:** High compression cage-clamp terminal block

Wire Strip Length: 0.3" (7.5 mm)

Wire Gauge Capacity: One 14 AWG (1.63 mm) solid, two 18 AWG (1.02 mm) or four 20 AWG (0.81 mm)

**CONSTRUCTION:** Cast aluminum enclosure with NEMA 4X/IP66 rating for indoor use only when correctly fitted with the gasket provided. These devices have only been evaluated for low risk of mechanical impact.

**WEIGHT:** 7.73 lb. (3.5 Kg)

**OPERATOR INTERFACE INSTALLATION**

**MOUNTING INSTRUCTIONS**

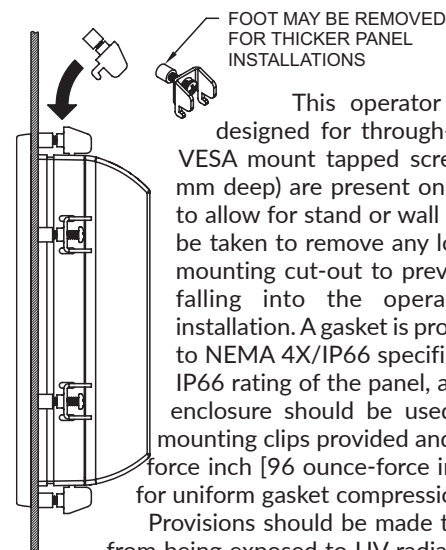

This operator interface is primarily designed for through-panel mounting. Four VESA mount tapped screw-holes (M4 x 0.7, 5 mm deep) are present on the rear of the panels to allow for stand or wall mounting. Care should be taken to remove any loose material from the mounting cut-out to prevent that material from falling into the operator interface during installation. A gasket is provided to enable sealing to NEMA 4X/IP66 specification. To maintain the IP66 rating of the panel, an equivalently IP rated enclosure should be used. Install the eighteen mounting clips provided and tighten to 6.0 pound-force inch [96 ounce-force inch] (0.68 N m) evenly for uniform gasket compression.

Provisions should be made to prohibit the product from being exposed to UV radiation while in use. Care should be taken not to rub or buff the touchscreen surface in a way that might cause the accumulation of static charges.

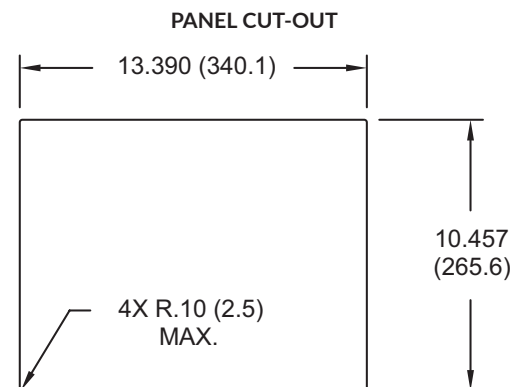
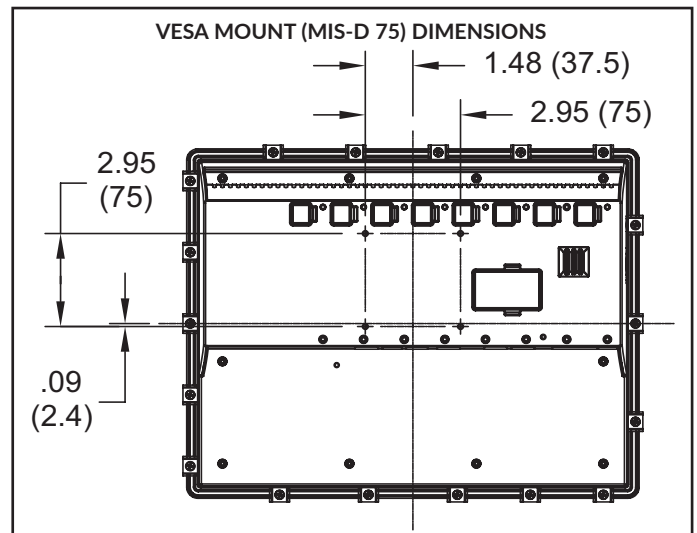

All tolerances ±.059" (±1.5 mm)

For hazardous location installation the following shall be taken into consideration:

- When used in a Zone 22 environment, the device shall be panel mounted in at least Zone 22 IECEX/ATEX-Certified tool accessible enclosure with a minimum ingress protection rating of at least IP64 as defined in IEC/EN 60529.
- When used in a Zone 2 environment, the device shall be panel mounted in at least Zone 2 IECEX/ATEX-Certified tool accessible enclosure with a minimum ingress protection rating of at least IP54 as defined in IEC/EN 60529.
- This device is open-type and must be mounted in a suitable dusttight end-enclosure in accordance with articles 500 and 502 of the NEC and positioned so only the face of the display is exposed.
- Must be wired using Division 2 wiring methods as specified in article 501-4(b), 502-4(b), and 503-3(b) of the National Electric Code, NFPA 70 for installation within the United States, or as specified in section 19-152 of Canadian Electrical Code for installation in Canada.

**CONNECTING TO EARTH GROUND**

Each operator panel has a chassis ground terminal on the back of the unit. Your unit should be connected to earth ground. Steps should be taken beyond connecting to earth ground to eliminate the buildup of electrostatic charges.

The chassis ground is not connected to signal common of the unit. Maintaining isolation between earth ground and signal common is not required to operate your unit. But, other equipment connected to this unit may require isolation between signal common and earth ground. *To maintain isolation between signal common and earth ground care must be taken when connections are made to the unit.* For example, a power supply with isolation between its signal common and earth ground must be used. Also, plugging in a USB cable may connect signal common and earth ground.<sup>1</sup>

<sup>1</sup> USB's shield may be connected to earth ground at the host. USB's shield in turn may also be connected to signal common.

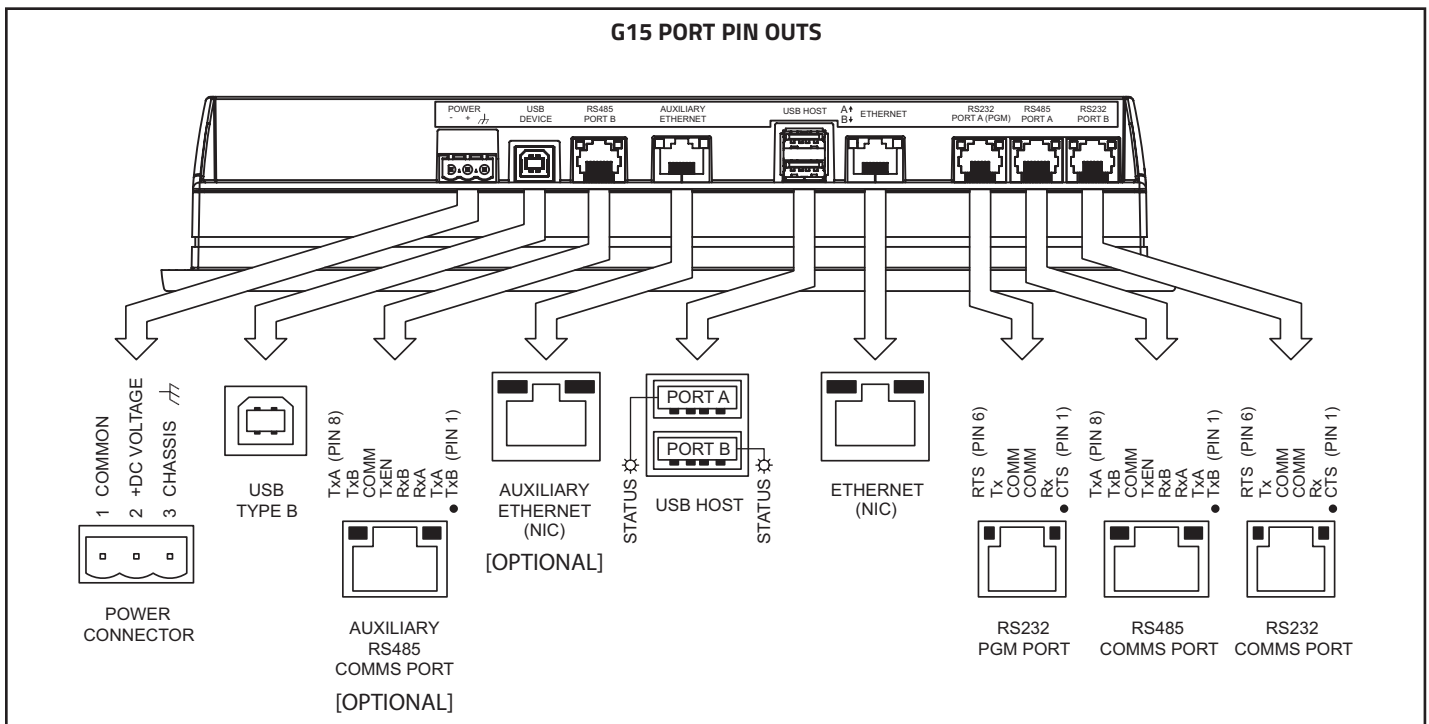

**POWER SUPPLY REQUIREMENTS**

The G15 requires a 10-30 VDC power supply. Your unit may draw considerably less than the maximum rated power depending upon the features being used. As additional features are used your unit will draw increasing amounts of power. Items that could cause increases in current are modules, additional on-board communications, SD card, and other features programmed through Crimson.

To ensure you do not exceed the capacity of your Graphite host power supply, calculate the total power consumption required for all of your planned modules. Each module's maximum power consumption is listed in the Specifications of their Product Bulletin. The total power available for modules is listed in the specifications of the Graphite host.

In any case, it is very important that the power supply is mounted correctly if the unit is to operate reliably. Please take care to observe the following points:

- The power supply must be mounted close to the unit, with usually not more than 6 feet (1.8 m) of cable between the supply and the operator interface. Ideally, the shortest

length possible should be used.

- The wire used to connect the operator interface's power supply should be at least 22-gage wire suitably rated for the temperatures of the environment to which it is being installed. If a longer cable run is used, a heavier gage wire should be used. The routing of the cable should be kept away from large contactors, inverters, and other devices which may generate significant electrical noise.
- A power supply with an NEC Class 2 or Limited Power Source (LPS) and SELV rating is to be used. This type of power supply provides isolation to accessible circuits from hazardous voltage levels generated by a mains power supply due to single faults. SELV is an acronym for "safety extra-low voltage." Safety extra-low voltage circuits shall exhibit voltages safe to touch both under normal operating conditions and after a single fault, such as a breakdown of a layer of basic insulation or after the failure of a single component has occurred. A suitable disconnect device shall be provided by the end user.

## I/O MODULE INSTALLATION

The physical order of all installed modules must match the modules order in Crimson. Torque screws to 6.0 pound-force inch [96 ounce-force inch] (0.68 N m).

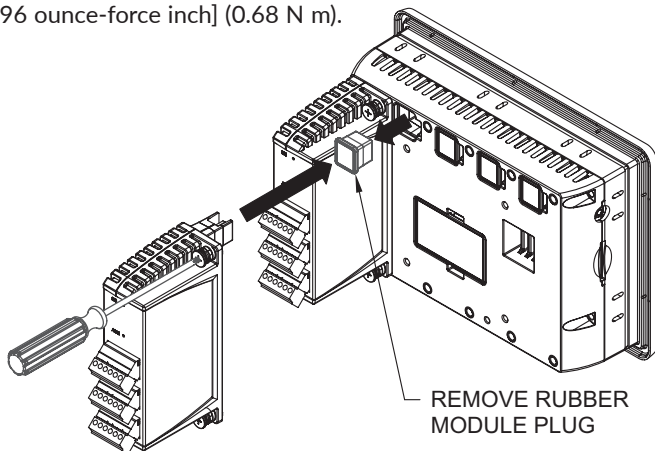

**WARNING:** Disconnect all power to the unit before installing or removing modules.

## INSERTION/REMOVAL OF THE SD CARD

Insert the SD card into the slot provided with the card oriented as shown. The card is inserted properly when the end of the card is flush with the Graphite case. To remove the SD card, push in slightly on the card.

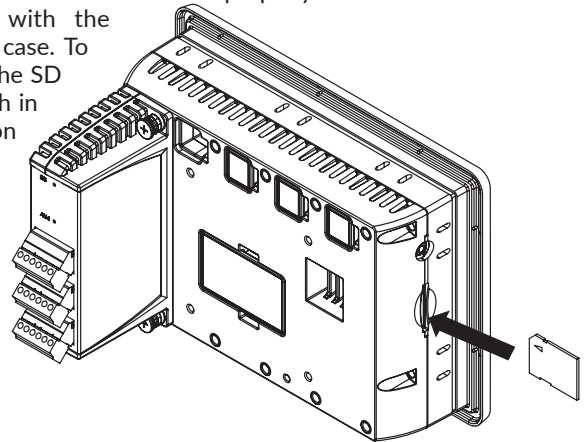

## BATTERY & TIME KEEPING

**WARNING - EXPLOSION HAZARD -** Disconnect power and ensure the areas is known to be non-hazardous before servicing/replacing the unit and before installing or removing I/O wiring and battery.

## COMMUNICATING WITH THE G15 CONFIGURING A G15

The G15 is configured using Crimson® software. Crimson is available as a no charge download from Red Lion's website. Crimson updates for new features and drivers are posted on the website as they become available. By configuring the G15 using the latest Crimson version, you are assured that your unit has the most up to date feature set. Crimson software can configure the G15 through the RS232 PGM port, USB port, or SD card

The USB port is connected using a standard USB cable with a Type B connector. The driver needed to use the USB port will be installed with Crimson.

The RS232 PGM port uses a programming cable made by Red Lion to connect to the DB9 COM port of your computer. If you choose to make your own cable, use the "G15 Port Pin Out Diagram" for wiring information.

The SD can be used to program a G15 by placing a configuration file and firmware on the SD card. The card is then inserted into the target G15 and powered. Refer to the Crimson literature for more information on the proper names and locations of the files.

## USB, DATA TRANSFERS FROM THE SD CARD

**WARNING -** Do not connect or disconnect cables while power is applied unless area is known to be non-hazardous. USB device port is for system set-up and diagnostics and is not intended for permanent connection.

In order to transfer data from the SD card via the USB port, a driver must be installed on your computer. This driver is installed with Crimson and is located in the folder C:\Program Files\Red Lion Controls\Crimson 3.0\Device\ after Crimson is installed. This may have already been accomplished if your G15 was configured using the USB port.

Once the driver is installed, connect the G15 to your PC with a USB cable, and follow "Mounting the SD" instructions in the Crimson 3 user manual.

A battery is used to keep time when the unit is without power. Typical accuracy (at 25°C) of the Graphite time keeping is less than one minute per month drift. The battery of a Graphite unit does not affect the unit's memory, all configurations and data is stored in non-volatile memory.

### Changing the Battery

To change the battery of a Graphite, first remove power to the unit. Remove the battery cover. Grasp the top edge of the battery and push to the left to remove the battery from the holder. Lift the battery out and replace with a new battery.

Replace the battery cover, and re-apply power. Using Crimson or the unit's keypad, enter the correct time and date.

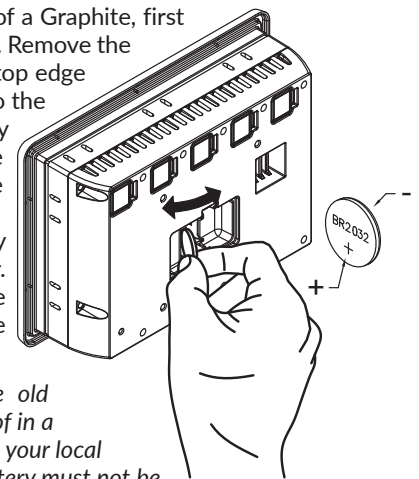

\* Please note that the old battery must be disposed of in a manner that complies with your local waste regulations. The battery must not be disposed of in fire, or in a manner whereby it may be damaged and its contents could come into contact with human skin.

The battery used by the panel is a lithium type BR2032.

## RED LION CONTROLS TECHNICAL SUPPORT

If for any reason you have trouble operating, connecting, or simply have questions concerning your new product, contact Red Lion's technical support.

Support: [support.redlion.net](http://support.redlion.net) Inside US: +1 (877) 432-9908  
 Website: [www.redlion.net](http://www.redlion.net) Outside US: +1 (717) 767-6511

Red Lion Controls, Inc.  
 35 Willow Springs Circle York, PA 17406