

Model GMJ1939 - Graphite® J1939 Module Installation Guide



- Configured using Crimson® software (version 3.0 or later)
- Digitally isolated J1939 port capable of communicating with any J1939 device
- Powered and configured from Graphite host device
- Built-in termination resistor selectable through a switch

UL LISTED
 IND. CONT. EQ.
 E317425

FOR USE IN HAZARDOUS LOCATIONS:
 Class I, Division 2, Groups A, B, C, and D
 T4

UL US LISTED
 IND. CONT. EQ.
 E302106



UK CA **CE** **Ex** II 3 G Ex nA IIC T4 Gc
 -40°C ≤ T_{AMB} ≤ 75°C
 DEMKO 14 ATEX 1387X
 IECEx UL 15.0035X
 UL22UKEX2574X

GENERAL DESCRIPTION

The model GMJ1939 is a J1939 communication module designed for use with the Graphite products. The module provides the Graphite host device a J1939 communications port. It is built with digital isolation to protect the Graphite host device from the J1939 bus and vice versa. It provides the ability to communicate to any J1939 device. The GMJ1939 module has a termination resistor built-in, and is selectable through a switch. The connector is pluggable for easy removal of the GMJ1939 module from the J1939 bus, without disturbing communications with other devices on the bus.

The modules connect and communicate via proprietary USB connection to the various Graphite devices. The Graphite devices, equipped with serial ports as well as Ethernet port(s), allows the system to share data with PCs, PLCs and SCADA systems. The maximum number of modules varies for each Graphite device, see specific model for details. Remove power from the host device before installing or replacing any modules.

CONFIGURATION

The Graphite is configured with Windows® compatible Crimson 3 software. The software is an easy to use, graphical interface which provides a means of configuration and commissioning of new systems, as well as routine module re-calibration.

SAFETY SUMMARY

All safety related regulations, local codes and instructions that appear in this document or on equipment must be observed to ensure personal safety and to prevent damage to either the device or equipment connected to it.

Do not use these products to replace proper safety interlocking. No software-based device (or any other solid-state device) should ever be designed to be responsible for the maintenance of personnel safety or consequential equipment not equipped with safeguards. Red Lion disclaims any responsibility for damages, either direct or consequential, that result from the use of this equipment in a manner not specified.

 **CAUTION: Risk of Danger.**
 Read complete instructions prior to installation and operation of the unit.

 **WARNING - EXPLOSION HAZARD** - Do not disconnect equipment unless power has been switched off or area is known to be non-hazardous.

 **WARNING - EXPLOSION HAZARD** - Substitution of components may impair suitability for Class I, Division 2

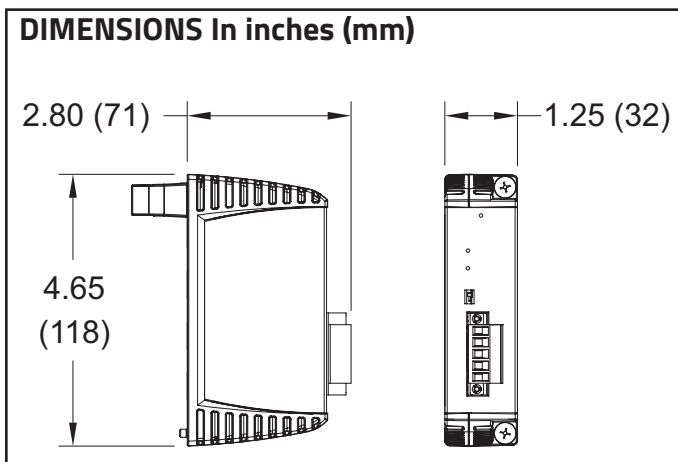

ORDERING INFORMATION

DESCRIPTION	PART NUMBER
Graphite Module, J1939 Interface	GMJ19390

A listing of the entire Graphite family of products and accessories can be found at www.redlion.net.

SPECIFICATIONS

1. **POWER REQUIREMENTS:** Power will be supplied by the Graphite host device. Some modules, depending on usage may consume high levels of power. This may limit the total number of modules that can be installed on a single Graphite host. Check the Graphite module and Graphite host data sheets for specific usage and power requirements.

GMJ1939 Max Power: 1.2 W

2. **COMMUNICATIONS:**

J1939 Port: The J1939 port has format and baud rates that are software programmable up to 250K baud and is digitally isolated. 124 ohm, 1W termination is provided through a switch. This port may be configured for various J1939 protocols.

Isolation from GMJ1939 Communication ports to Graphite host device: 1000 VDC for 1 minute.

3. **ENVIRONMENTAL CONDITIONS:**

Operating Temperature Range: -40 to +75 °C T_{AMB}, or lowest range among equipment used in your Graphite system. Consult the user manual or www.redlion.net/OpTemp for further details.

Storage Temperature Range: -40 to +85 °C T_{AMB}

Operating and Storage Humidity: 85% max relative humidity, non-condensing

Altitude: Up to 2000 meters

4. **CERTIFICATIONS AND COMPLIANCES:**

CE Approved

EN 61326-1 Immunity to Industrial Locations
IEC/EN 61010-1
RoHS Compliant

ATEX Approved

II 3 G Ex nA IIC T4 Gc
DEMKO 14 ATEX 1387X
EN 60079-0, -15

IECEx Approved

Ex nA IIC T4 Gc
IECEx UL 15.0035X

IEC 60079-0, -15

UKEX Approved

UL22UKEX2574X

UL Listed: File #E302106

UL Hazardous: File #E317425

ABS Type Approval for Shipboard Applications

5. **CONSTRUCTION:** Case body is all metal construction.

6. **CONNECTIONS:** Removable wire clamp screw terminal block. Wire Gage: 28-14 AWG (0.32 mm - 1.63 mm) terminal gage wire.

Torque: 1.95-2.21 inch-lbs (0.22 - 0.25 N-m)

7. **MOUNTING:** Screws to host.

8. **WEIGHT:** 6.9 oz (196 g)

Block Diagram from GMJ1939

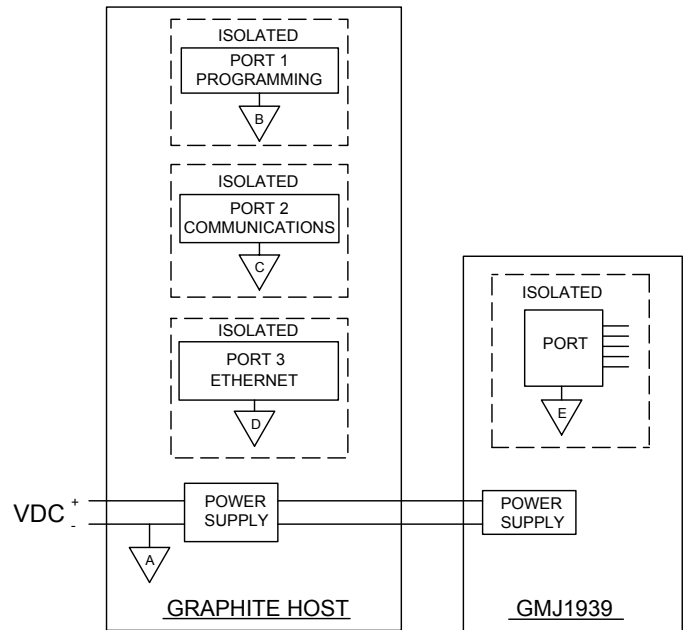

EMC INSTALLATION GUIDELINES

Although Red Lion Controls products are designed with a high degree of immunity to Electromagnetic Interference (EMI), proper installation and wiring methods must be followed to ensure compatibility in each application. The type of the electrical noise, source or coupling method into a unit may be different for various installations. Cable length, routing, and shield termination are very important and can mean the difference between a successful or troublesome installation. Listed are some EMI guidelines for a successful installation in an industrial environment.

1. A unit should be mounted in a metal enclosure, which is properly connected to protective earth.
2. Use shielded cables for all Signal and Control inputs. The shield connection should be made as short as possible. The connection point for the shield depends somewhat upon the application. Listed below are the recommended methods of connecting the shield, in order of their effectiveness.
 - a. Connect the shield to earth ground (protective earth) at one end where the unit is mounted.
 - b. Connect the shield to earth ground at both ends of the cable, usually when the noise source frequency is over 1 MHz.
3. Never run Signal or Control cables in the same conduit or raceway with AC power lines, conductors, feeding motors, solenoids, SCR controls, and heaters, etc. The cables should be run through metal conduit that is properly grounded. This is especially useful in applications where cable runs are long and portable two-way radios are used in close proximity or if the installation is near a commercial radio transmitter. Also,

Signal or Control cables within an enclosure should be routed as far away as possible from contactors, control relays, transformers, and other noisy components.

4. Long cable runs are more susceptible to EMI pickup than short cable runs.
5. In extremely high EMI environments, the use of external EMI suppression devices such as Ferrite Suppression Cores for signal and control cables is effective. The following EMI suppression devices (or equivalent) are recommended: Fair-Rite part number 0443167251 (Red Lion #FCOR0000) Line Filters for input power cables: Schaffner # FN2010-1/07 (Red Lion #LFIL0000)
6. To protect relay contacts that control inductive loads and to minimize radiated and conducted noise (EMI), some type of contact protection network is normally installed across the load, the contacts or both. The most effective location is across the load.
 - a. Using a snubber, which is a resistor-capacitor (RC) network or metal oxide varistor (MOV) across an AC inductive load is very effective at reducing EMI and increasing relay contact life.
 - b. If a DC inductive load (such as a DC relay coil) is controlled by a transistor switch, care must be taken not to exceed the breakdown voltage of the transistor when the load is switched. One of the most effective ways is to place a diode across the inductive load. Most Red Lion products with solid state outputs have internal zener diode protection. However external diode protection at the load is always a good design practice to limit EMI. Although the

use of a snubber or varistor could be used.
 Red Lion part numbers: Snubber: SNUB0000
 Varistor: ILS11500 or ILS23000

- Care should be taken when connecting input and output devices to the instrument. When a separate input and output common is provided, they should not be mixed. Therefore a sensor common should NOT be connected to an output

common. This would cause EMI on the sensitive input common, which could affect the instrument's operation.

Visit <http://www.redlion.net/emi> for more information on EMI guidelines, Safety and CE issues as they relate to Red Lion products.

HARDWARE INSTALLATION

The physical order of all installed modules must match the modules order in Crimson. Torque screws to 6.0 pound-force inch [96 ounce-force inch] (0.68 Nm).

WARNING: Disconnect all power to the unit before installing or removing modules.

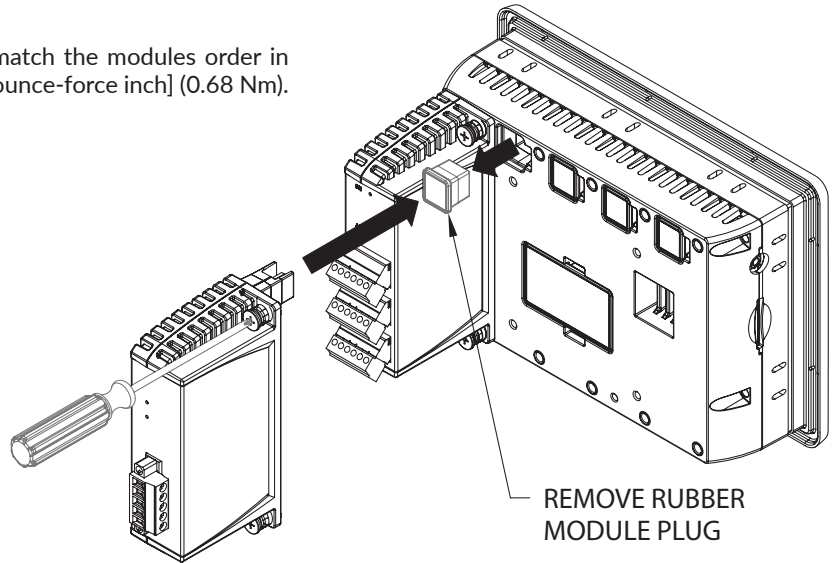

COMMUNICATING WITH THE GMJ1939 MODULE

CONFIGURATION

Programming is done via Crimson 3 software, a Windows® compatible configuration interface. Please see the Crimson manual for more information.

J1939 PORT PROTOCOLS

The GMJ1939 module has one J1939 port. This port may be configured for various J1939 protocols.

Figure 3. GMJ1939 PORT PIN OUTS

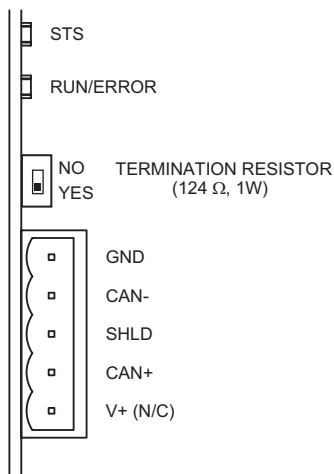

TERMINATION RESISTOR

An onboard termination resistor is selectable through a switch. The termination resistor is rated for 124Ω at 1W. If a different termination resistance is desired, slide the switch for no termination resistor. At this point you will be required to connect your own termination resistor between positions 2 and 4 of the five position connector.

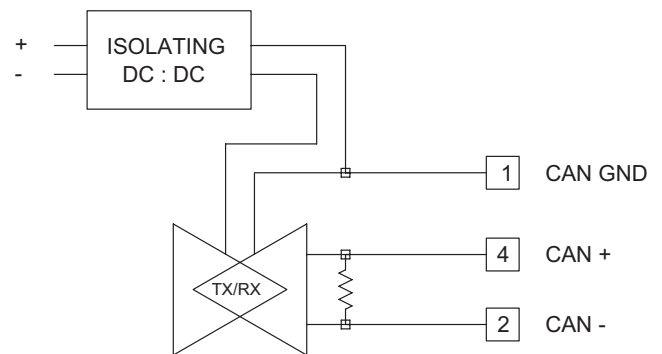

CAN GND

Position 1 of the pluggable connector provides a CAN ground connection. This terminal is isolated from the Graphite host device.

CAN-

Position 2 of the pluggable connector provides the CAN- bus line (active low). This terminal is isolated from the Graphite host device.

WARNING - EXPLOSION HAZARD - Do not connect or disconnect cables while power is applied unless area is known to be non-hazardous.

SHLD (CAN SHIELD)

Position 3 of the pluggable connector is provided for shield connections. This position is available to tie shield wires to earth ground. The SHLD position is connected through a series RC network to CHASSIS as noted in specification J1939-11. The SHLD connection is internally tied to the Graphite host device enclosure.

CAN+

Position 4 of the pluggable connector provides the CAN+ bus line (active high). This terminal is isolated from the Graphite host device.

V+ (OPTIONAL 24 VDC)

Position 5 of the pluggable connector is provided for optional 24 VDC connections. This position is available only to tie 24 VDC wires together. The GMJ1939 module neither provides 24 VDC power nor uses 24 VDC power through this connection. The V+ position is not connected to any circuitry internal to the GMJ1939 module or Graphite Host device.

LEDs

STS - STATUS LED

The Status LED is a green/red LED that provides information regarding the state of the module. This includes indication of the various stages of the start-up routine (power-up), as well as any errors that may occur.

Startup Routine

Flashing Red	Module is currently running the boot loader and/or being flash upgraded by Crimson.
Green	Module performing normally.

Error States

Flashing Green	Module has lost communication with the Host.
----------------	--

RUN/ERROR LED

Green	GMJ1939 module established communication with other J1939 devices (RUN) and is communicating normally.
Red	GMJ1939 module failed to establish communications with other J1939 devices (ERROR).

FIRMWARE UPGRADE

The module's firmware is stored in flash memory so that software/hardware conflicts are avoided, and so features can be added in the future.

During a download, Crimson compares its own library of firmware files with those stored in the module. If they do not match, Crimson will download the necessary firmware.

RED LION CONTROLS TECHNICAL SUPPORT

If for any reason you have trouble operating, connecting, or simply have questions concerning your new product, contact Red Lion's technical support.

Support: support.redlion.net

Website: www.redlion.net

Inside US: +1 (877) 432-9908

Outside US: +1 (717) 767-6511

Red Lion Controls, Inc.

35 Willow Springs Circle York, PA 17406

COPYRIGHT

©2023 Red Lion Controls, Inc. All rights reserved. Red Lion and the Red Lion logo are trademarks of Red Lion Controls, Inc. All other company and product names are trademarks of their respective owners.

LIMITED WARRANTY

(a) Red Lion Controls Inc. (the "Company") warrants that all Products shall be free from defects in material and workmanship under normal use for the period of time provided in "Statement of Warranty Periods" (available at www.redlion.net) current at the time of shipment of the Products (the "Warranty Period"). **EXCEPT FOR THE ABOVE-STATED WARRANTY, COMPANY MAKES NO WARRANTY WHATSOEVER WITH RESPECT TO THE PRODUCTS, INCLUDING ANY (A) WARRANTY OF MERCHANTABILITY; (B) WARRANTY OF FITNESS FOR A PARTICULAR PURPOSE; OR (C) WARRANTY AGAINST INFRINGEMENT OF INTELLECTUAL PROPERTY RIGHTS OF A THIRD PARTY; WHETHER EXPRESS OR IMPLIED BY LAW, COURSE OF DEALING, COURSE OF PERFORMANCE, USAGE OF TRADE OR OTHERWISE.** Customer shall be responsible for determining that a Product is suitable for Customer's use and that such use complies with any applicable local, state or federal law.

(b) The Company shall not be liable for a breach of the warranty set forth in paragraph (a) if (i) the defect is a result of Customer's failure to store, install, commission or maintain the Product according to specifications; (ii) Customer alters or repairs such Product without the prior written consent of Company.

(c) Subject to paragraph (b), with respect to any such Product during the Warranty Period, Company shall, in its sole discretion, either (i) repair or replace the Product; or (ii) credit or refund the price of Product provided that, if Company so requests, Customer shall, at Company's expense, return such Product to Company.

(d) **THE REMEDIES SET FORTH IN PARAGRAPH (c) SHALL BE THE CUSTOMER'S SOLE AND EXCLUSIVE REMEDY AND COMPANY'S ENTIRE LIABILITY FOR ANY BREACH OF THE LIMITED WARRANTY SET FORTH IN PARAGRAPH (a).**

BY INSTALLING THIS PRODUCT, YOU AGREE TO THE TERMS OF THIS WARRANTY, AS WELL AS ALL OTHER DISCLAIMERS AND WARRANTIES IN THIS DOCUMENT.