

▶▶▶ Industrial I/O Controller

PRODUCT HIGHLIGHTS

- Process Control, SCADA, and RTU functionality
- IEC 61131-3 programming with all five languages supported datalogging and peer-to-peer I/O transfers
- Ethernet, RS232, RS485 and local I/O Expansion
- Supports more than 40 Sixnet I/O modules Types
- Interface to other vendor's Modbus I/O
- Flexible communication
- Supports open Modbus/TCP, ASCII and RTU
- Supports telephone, wireless and other links
- Compact DIN-rail industrial package
- Zone 2 UL, CSA, CE and DNV rated
- -30 to +70°C operating temperature range

PERFORMANCE SPECIFICATIONS

- 32-bit CPU
- 16 Meg flash and 16 Meg dynamic RAM
- 512K battery-backed static RAM
- Up to 50,000 I/O registers
- Configuration and diagnostics from Sixnet I/O Toolkit software
- Datalogging support - Sixnet Sixlog
- IEC 61131 programming - Sixnet ISaGRAF

SixTRAK I/O (ST-BUS) PORT

- Up to 20 modules (640 I/O)
- SixTRAK I/O Specs - see individual data sheets
- ST-BUS Specs - see user manual for details

ETHERNET PORT

- 10/100 BaseTx auto-sensing
- Connection - RJ45 (TD, RD, CTS, RTS, CD, DTR, DSR, GND)
- Isolation - 1200 VRMS 1 minute
- Protocols - Modbus and Sixnet over TCP or UDP

SERIAL PORTS

- Up to 115,200 baud
- RS232 port RJ45 (TD, RD, CTS, RTS, CD, DTR, DSR, GND)
- RS485 port Screws (485+, 485-, GND) 2-wire half-duplex
- RS485 network - up to 32 (full-load) stations
- RS485 distance - up to 0.5 miles (1km)
- Flow control - hardware, software, half/full-duplex modem
- Protocols - Modbus RTU, Modbus ASCII, and Sixnet
- Modes - master, slave and passthru



ENVIRONMENTAL

- DIN rail or flat panel mount
- Power - 10-30 VDC; 3 watts typ. (less modules)
- Temperature -30 to +70°C (-40 to +85°C storage)
- Humidity 5% to 95% RH (non-condensing)
- Electrical safety UL508, CSA C22.2/14; EN61010-1
- EMI emissions FCC part 15, ICES-003, Class A; EN55022; EN61326-1; CE
- EMC immunity EN61326-1 (EN61000-4-2,3,4,6); CE
- Surge withstand IEEE-472 (ANSI C37.90)
- Vibration IEC68-2-6
- UL1604, CSA C22.2/213, Cenelec EN50021 Zone 2
- Marine/offshore tested and/or verified to meet various marine and maritime standards

All specifications are subject to change. Consult factory for latest info.

MECHANICAL DRAWING

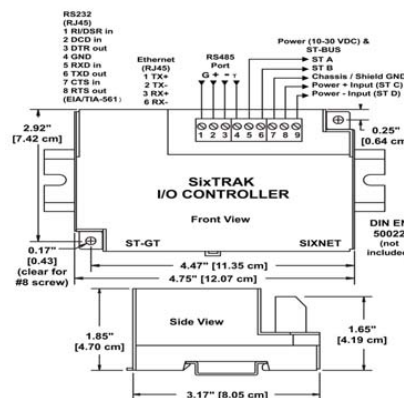

ORDERING INFORMATION

ST-GT-1210

SixTRAK I/O Controller