

# Monitor & Control Multiple EtherNet/IP Groups

Using ODVA Common Industrial Protocol to Enhance Performance

# Monitor & Control Multiple EtherNet/IP Groups

The variety of industrial applications that can be supported through the use of Ethernet technology continues to expand as the “Internet of Things” evolves into the “Industrial Internet of Things” and organizations work to improve operations through data integration. The networking requirements for applications can vary widely and most industrial networks will need to support a mix of Fast Ethernet (100Base) and Gigabit Ethernet (1000Base), or GigE, devices in the near future. After providing a foundation of industrial networking basics, this white paper will discuss when to choose GigE over Fast Ethernet through a series of application examples.

## Table of Contents

- Introduction** ..... **3**
- Typical EtherNet/IP Environment** ..... **3**
- Combining EtherNet/IP Networks** ..... **4**
- Using Port VLAN Routing to Isolate Control Networks** ..... **6**
- The Red Lion Advantage** ..... **8**

# Introduction

EtherNet/IP™ networks for I/O, drive and other control components are used in an increasing number of process control installations worldwide. This technology enables devices made by different vendors to communicate via standard Ethernet infrastructures that use the ODVA Common Industrial Protocol (CIP). These process networks can be monitored and controlled using a variety of switch-based topologies. The network configuration dictates performance, flexibility and connectivity to field devices when the PLC or Process Controller is not running. This whitepaper will discuss how to monitor and control multiple EtherNet/IP groups.



**"Red Lion N-Tron switches can be configured with multiple overlapping VLAN ports if more than one uplink port is required."**

# Typical EtherNet/IP Environment

As detailed in Figure 1, a typical EtherNet/IP environment represents a topology with field devices split between three EtherNet/IP controllers in a single PLC. The topology also breaks the control scheme into three separate networks that communicate with each other through the backplane of the PLC.

Control engineers will frequently build multiple EtherNet/IP networks for several reasons:

- System performance enhancements through increased bandwidth
- EtherNet/IP group multicast isolation

- Separate control levels such as I/O control, HMI supervision and enterprise communications
- Process control of individual network locations

A PLC that has been stopped intentionally or halted by a failure will force maintenance personnel to connect to each individual network to view connected field devices. This limits the ability of the system to use all of the troubleshooting options available in the switches and I/O. If commercial grade switches are used, MTBF is reduced from over one million to 25,000 to 50,000 hours with extreme conditions causing failure much sooner. This can complicate startup and data acquisition.

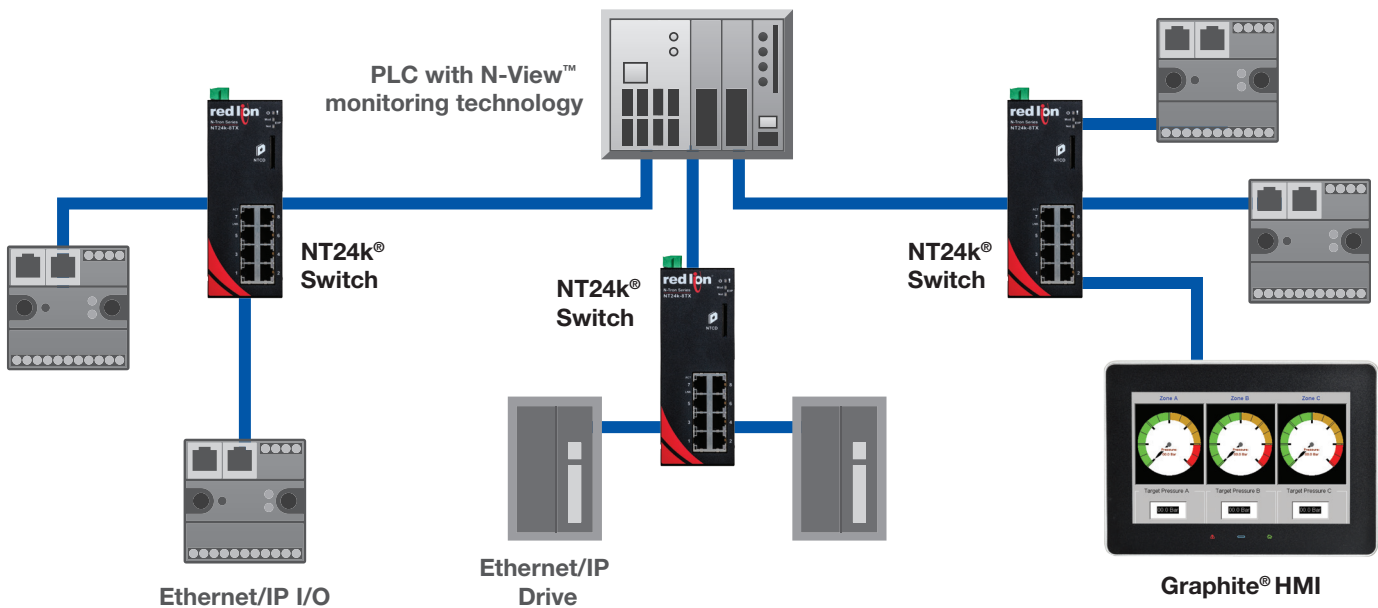

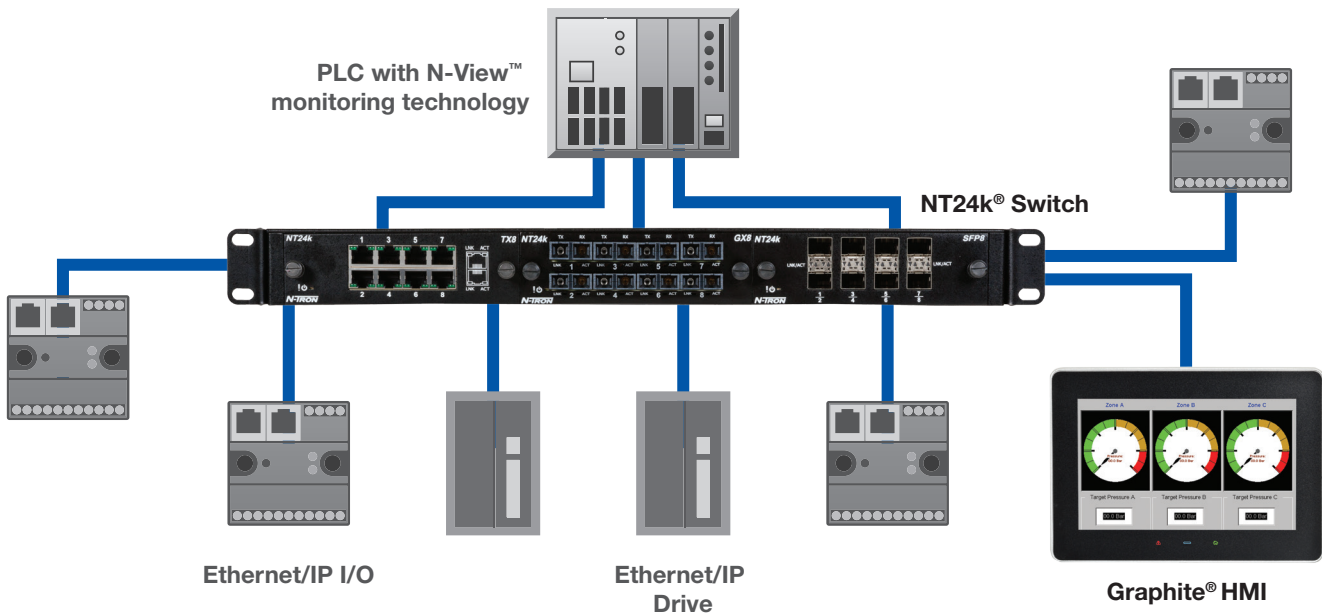

## Combining EtherNet/IP Networks

EtherNet/IP networks can be combined into a single topology that provides the ability to communicate directly to all devices during a PLC outage. The concerns listed above can be addressed by using network switches to combine EtherNet/IP control groups. As depicted in Figure 2, Red Lion N-Tron series NT24k switches are ideal for such applications.

As Figure 3 illustrates below, Red Lion N-Tron series NT24k switches can also be used to combine EtherNet/IP control groups over several switches located in different control areas. Red Lion N-Tron series NT24k switches are configured automatically in a multi-controller, EtherNet/IP environment. By detecting other managed Red Lion N-Tron series switches on the same network, each Red Lion N-Tron series switch is able to configure itself to handle the EtherNet/IP traffic in the most efficient manner.

In Figure 3, the three Red Lion N-Tron series NT24k-8TX Ethernet switches do not require user setup. NT24k switches require no IP address and will automatically perform the following EtherNet/IP setup:

- Internet Group Management Protocol (IGMP snooping) is enabled to allow each switch to route EtherNet/IP multicast packets efficiently through the switch.
- In networks using more than one switch, the switches vote and elect one switch to create IGMP queries periodically.

These queries will cause each IGMP Group Multicast consumer (each EtherNet/IP controller on the PLC) to send an IGMP group join signal to each connected switch. Each switch will log the EtherNet/IP group number transmitted by each controller. This group number is then stored along with the port number of the receiving port. Anytime an IGMP group multicast with this group number is detected entering the switch from field devices it will be routed to the proper consumer port.

- Each switch will detect the presence of another Red Lion N-Tron series switch connected to any of its ports and automatically establish bi-directional router port communication on these ports. The bi-directional router ports will forward all IGMP commands (IGMP group join and group leave commands) and IGMP multicasts to the other switches in the network so that these switches will know how to route IGMP multicasts across the network if necessary. IGMP commands are not forwarded to other switches unless the switch that receives these commands has established bi-directional router ports. If these ports are not setup properly the group multicasts from the field devices will be broadcast out all ports of the switches that have not received the group join routing information. This will cause devices that are sensitive to high traffic volumes (half duplex equipment, wireless products and RS-232/485 to Ethernet converters) to stop communicating properly and will cause general network congestion.

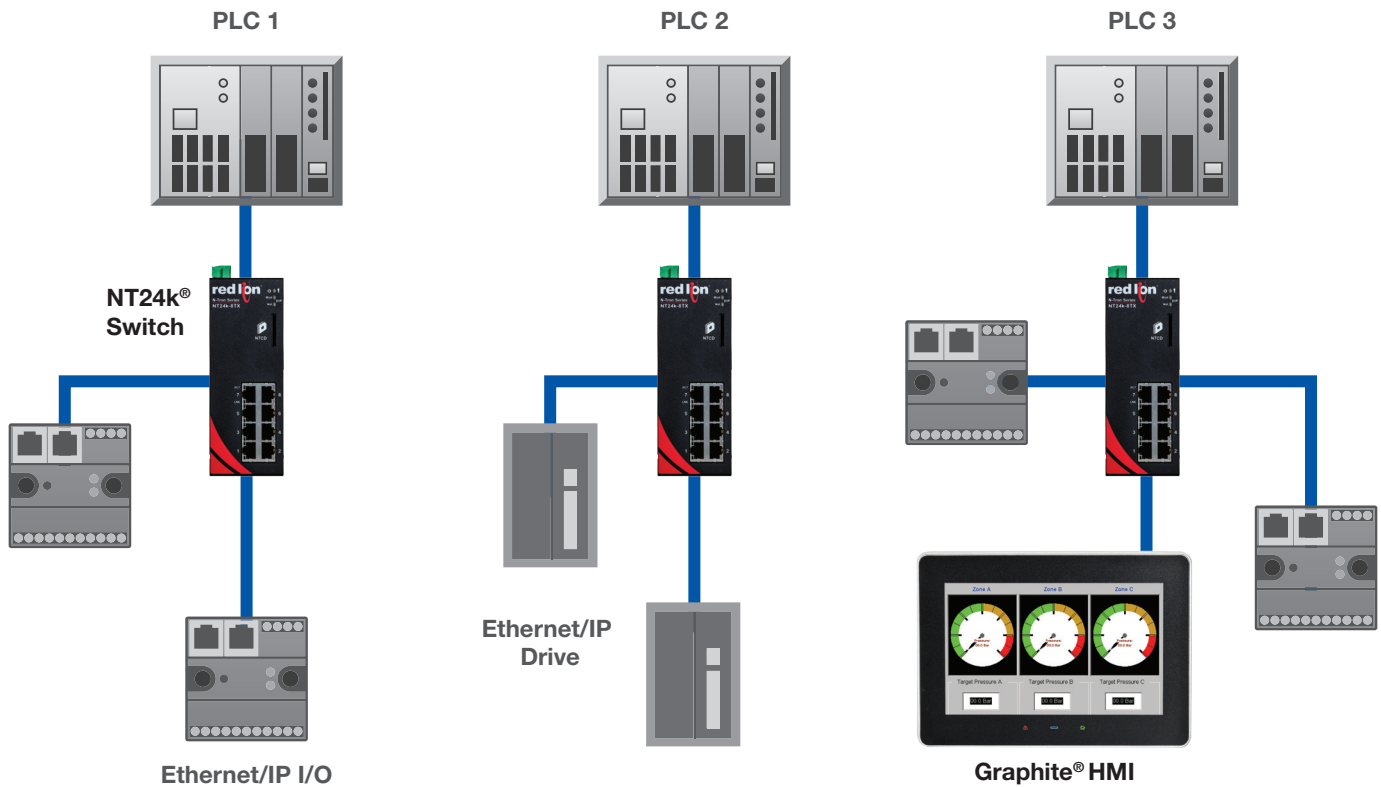

- A switch or router connected to an EtherNet/IP network may have no use for the EtherNet/IP multicasts being sent to it over the established bi-directional router ports; that is, it may have no IGMP consumer for the group in question. If these IGMP multicasts are sent to a network device over a bi-directional router port and this device has no consumers for the group address, it will broadcast these packets out through all ports. Red Lion N-Tron series switches with registered IGMP groups will prevent these group multicasts from being forwarded to ports with no IGMP consumer for that group by using an automatic port filtering feature (R-Filter), which prevents these multicasts from being transmitted out of a bi-directional router port that has not received an incoming IGMP group join for this group. R-Filter will also prevent these packets from flooding routers with unwanted traffic.

Once the Red Lion N-Tron series switches auto configure the network, the EtherNet/IP controllers will communicate with assigned field devices as shown in Figure 1. No unwanted traffic will be introduced into the control groups because each switch

will route EtherNet/IP multicasts only to the individual controller that requires the data. Communication between control groups is now possible without using the PLC backplane. This means that programming, setup and troubleshooting on the entire control network can be accomplished by connecting to any switch in the network. The HMI can directly monitor and control all CIP devices on the network and will be able to monitor the N-View OPC operational data from each NT24k switch in the control network. This flexibility is not possible when separate networks are used.

The N-View Ethernet heartbeats generated by each switch are multicasts and will not be transferred over the PLC backplane. Creating a single control network will allow data from all switches to be monitored from anywhere in the control network.

As Figure 4 shows, EtherNet/IP control schemes using multiple PLCs can be configured to use one network to improve access to all PLCs, CIP field devices and switches from any switch port on the network. The Red Lion N-Tron series NT24k switches will automatically isolate the EtherNet/IP multicasts from each control group and provide N-View OPC diagnostics from all switches.

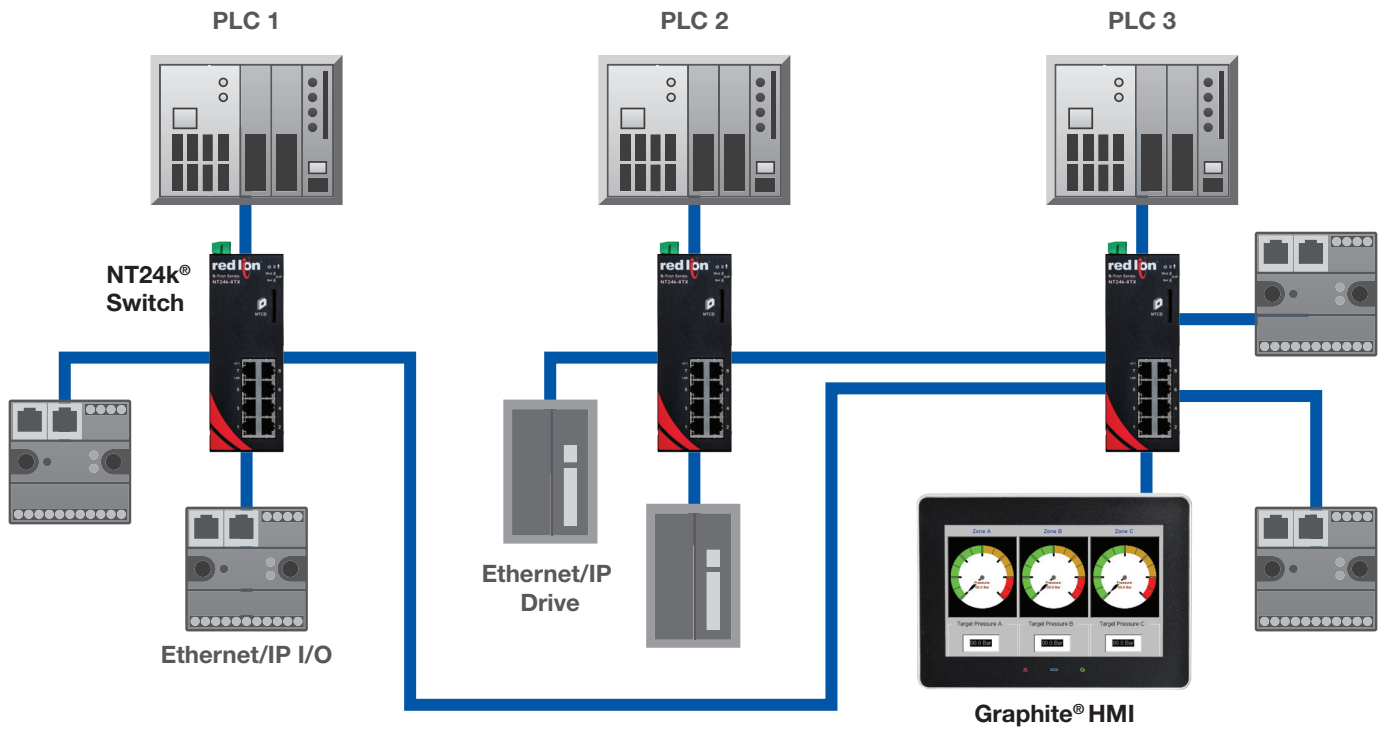

## Using Port VLAN Routing to Isolate Control Networks

Red Lion N-Tron series NT24k switches can be used to form separate VLAN networks isolating each EtherNet/IP control group. With typical industrial Ethernet switches, it is necessary to control EtherNet/IP multicast traffic. This is not the case with a network consisting of Red Lion N-Tron series 500-A, 700, or NT24k switches, but it may be desirable for security reasons

to isolate the plant floor from the HMI network or the enterprise network. As depicted in Figure 5, the overlapping port VLAN feature allows VLAN routing on a selected port enabling this port to communicate across a multiple port VLANs configuration with no external router necessary.

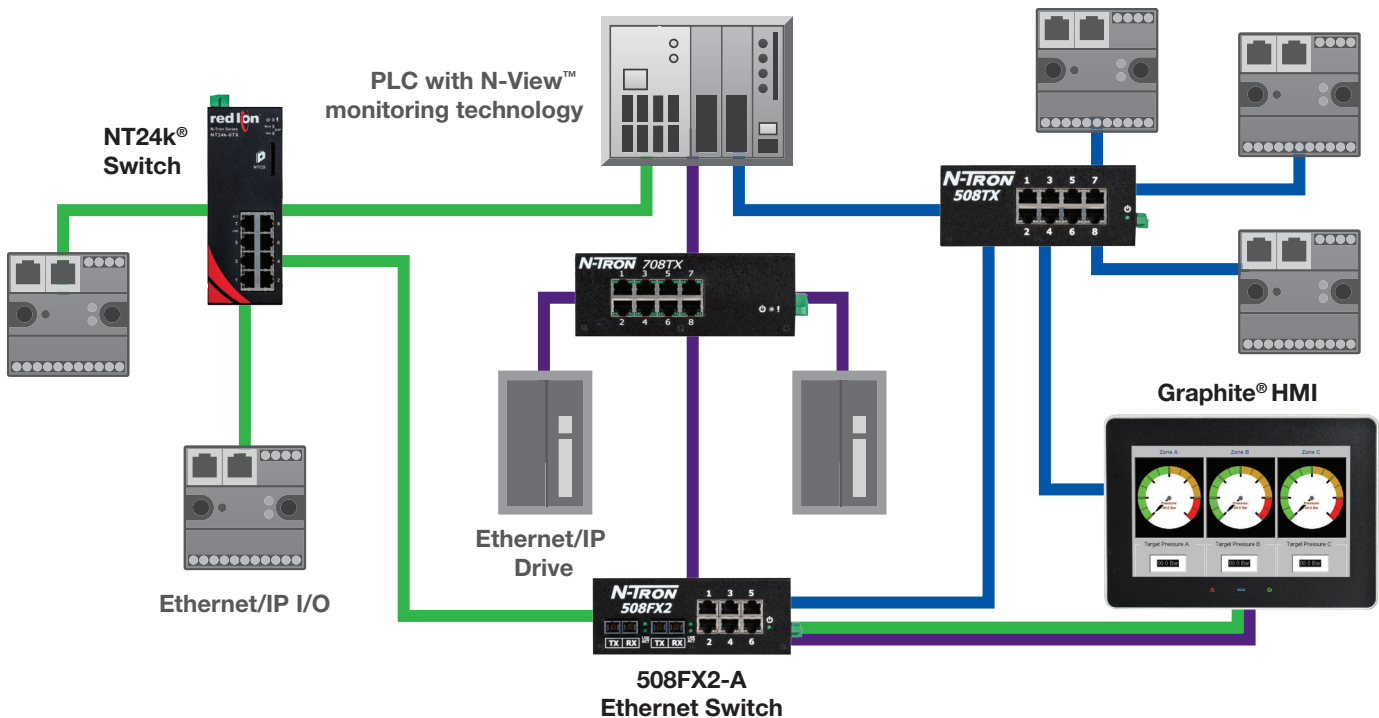

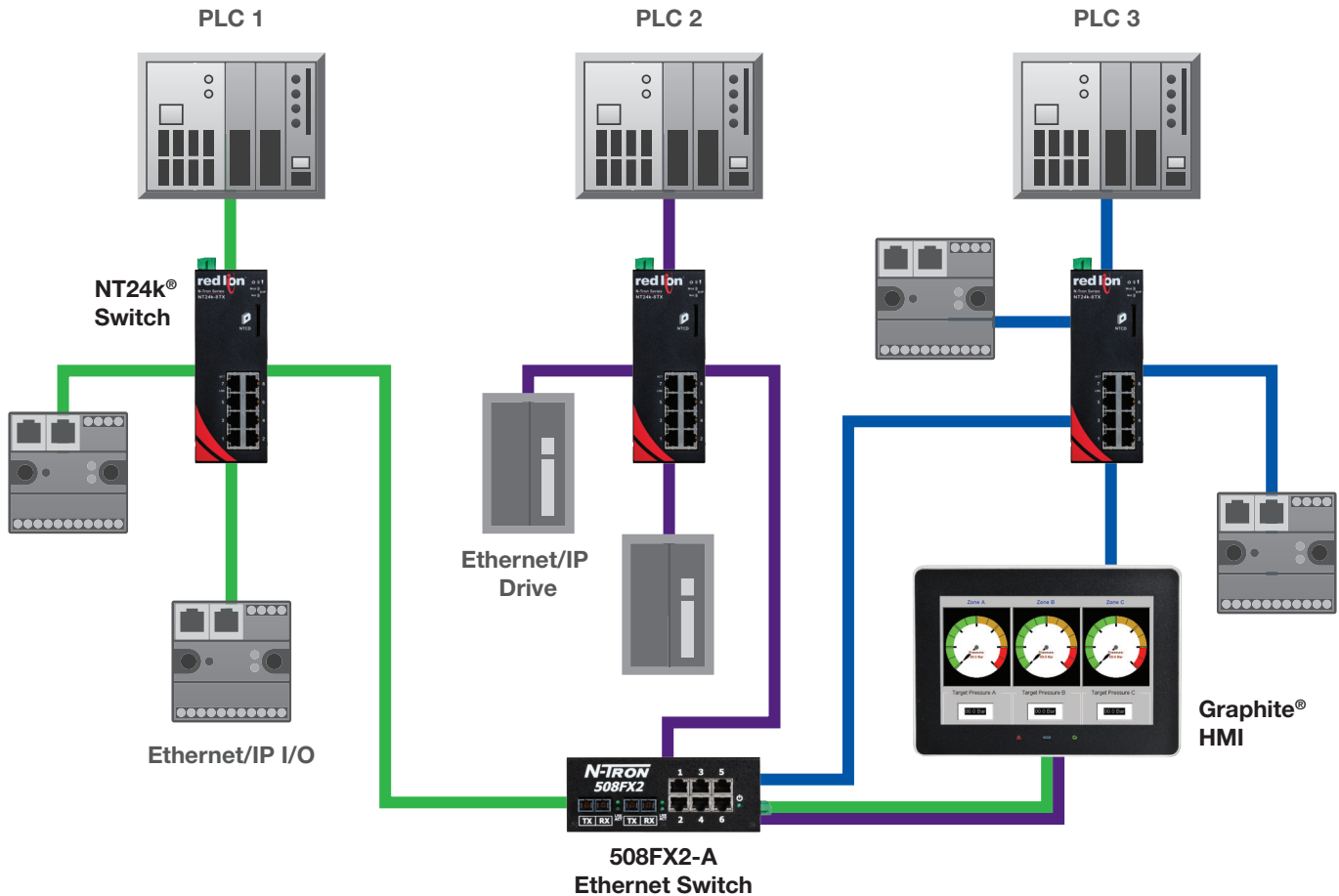

Red Lion N-Tron series switches can be configured with multiple overlapping VLAN ports if more than one uplink port is required. Connected end devices do not need to be VLAN capable. N-View OPC and CIP data from all control devices and switches will be transported across the Overlapping VLAN ports for monitoring, control and troubleshooting purposes.

Red Lion N-Tron series 700, 7000 and NT24k switches can be used in EtherNet/IP control networks and will provide all of the same capabilities as the 500 switches in addition to many new system options. The PLCs and HMI can monitor and control all 700 and 7000 series\* switches using ODVA CIP. All Dynamic Host Protocol (DHCP) clients can be served IP addresses from a NT24k/7000/700 DHCP server\* either dynamically from an IP pool or with fixed IP addresses using DHCP option 61, option 82 or direct port base IP addressing.

Fixed IP addressing is required for all EtherNet/IP control PLCs and field devices because these devices are preprogrammed to use fixed IP addresses to communicate with each other. The IP addresses of the system's PLCs and field devices can be programmed into the DHCP server. As Figure 6 shows, switches in each control network will serve these addresses port by port to the PLCs and field devices connected to the ports of each switch configured as an option 82 relay (see Figure 6). PLCs or field devices that fail can be replaced and will receive the same IP address as the original device. This will allow maintenance personnel to replace malfunctioning equipment without the necessity of loading the IP address in the replacement equipment, eliminating the possibility of errors.



## The Red Lion Advantage



As global experts in communication, monitoring and control for industrial automation and networking, Red Lion has been delivering innovative solutions for over forty years. Our automation, Ethernet and cellular M2M technology enables companies worldwide to gain real-time data visibility that drives productivity. Product brands include Red Lion, N-Tron and Sixnet. With headquarters in York, Pennsylvania, the company has offices across the Americas, Asia-Pacific and Europe. Red Lion is part of Spectris plc, the productivity-enhancing instrumentation and controls company. For more information, please visit [www.redlion.net](http://www.redlion.net).

©2019 Red Lion Controls, Inc. All rights reserved. Red Lion, the Red Lion logo, N-Tron and Sixnet are registered trademarks of Red Lion Controls, Inc. All other company and product names are trademarks of their respective owners.



**Americas**  
sales@redlion.net

**Asia-Pacific**  
asia@redlion.net

**Europe, Africa  
Middle East**  
europe@redlion.net

**+1 (717) 767-6511**

**EXCELLENCE. REDEFINED.**  
[www.redlion.net](http://www.redlion.net)

ADLD0443 071819