

MODEL CTL - AVERAGE RESPONDING AC CURRENT TRANSDUCERS

- AVERAGE RESPONDING OUTPUT: 0-10 VDC or 4-20 mA
- JUMPER SELECTABLE RANGES
- OUTPUT IS MAGNETICALLY ISOLATED FROM THE INPUT
- SPLIT-CORE AND FIXED-CORE CASES



GENERAL DESCRIPTION

CTL Series transducers combine a current transformer and a signal conditioner into a single package. This provides higher accuracy, lower wiring costs, easier installation and saves valuable panel space.

The CTL Series transducers have jumper selected current input ranges and industry standard 0-10 VDC or 4-20 mA outputs. The CTL Series is designed for application on "linear" or sinusoidal AC loads. Available in a split-core or solid-core case. Select the CTL Series for constant speed loads or On/Off loads.

SAFETY SUMMARY

All safety regulations, local codes and instructions that appear in this and corresponding literature, or on equipment, must be observed to ensure personal safety and to prevent damage to either the instrument or equipment connected to it. If equipment is used in a manner not specified by the manufacturer, the protection provided by the equipment may be impaired.

Do not use this unit to directly command motors, valves, or other actuators not equipped with safeguards. To do so, can be potentially harmful to persons or equipment in the event of a fault to the unit.

SPECIFICATIONS

- | | | |
|----------------------------|---------------------|-----------------------------|
| | 0-10 VDC | 4-20 mA |
| 1. OUTPUT SIGNAL: | 0-10 VDC | 4-20 mA |
| 2. OUTPUT LIMIT: | 15 VDC | 40 mA |
| 3. FREQUENCY RANGE: | 50-60 Hz | 20-100 Hz |
| 4. RESPONSE TIME: | 100 msec | 300 msec |
| 5. ACCURACY: | 1.0% FS | 0.5% FS |
| 6. POWER SUPPLY: | Self-powered | 24 VDC Nominal, 40 VDC max. |
| 7. INPUT RANGES: | (Jumper Selectable) | |

PART NUMBER	RANGE	MAXIMUM		
		CONTINUOUS	6 SEC	1 SEC
CTL005_ _	2 A	80 A	125 A	250 A
	5 A	100 A	125 A	250 A
CTL050_ _	10 A	80 A	125 A	250 A
	20 A	110 A	150 A	300 A
	50 A	175 A	215 A	400 A
CTL200_ _	100 A	200 A	300 A	600 A
	150 A	300 A	450 A	800 A
	200 A	400 A	500 A	1000 A

CAUTION: Risk Of Danger.
Read complete instructions prior to installation and operation of the unit.

CAUTION: Risk of electric shock.

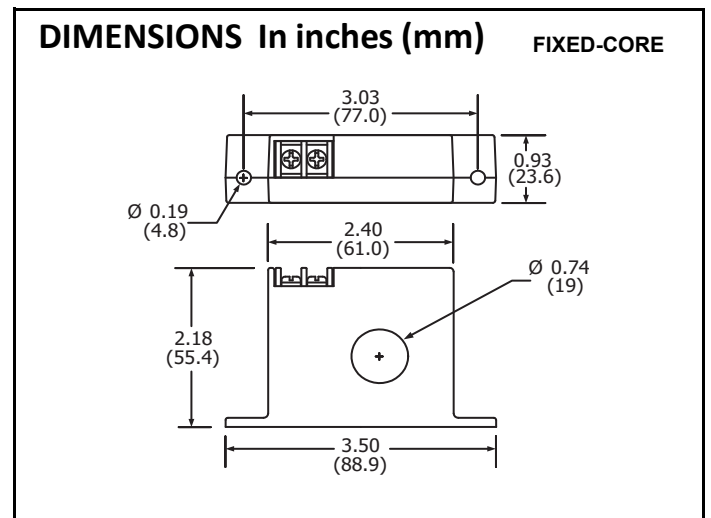
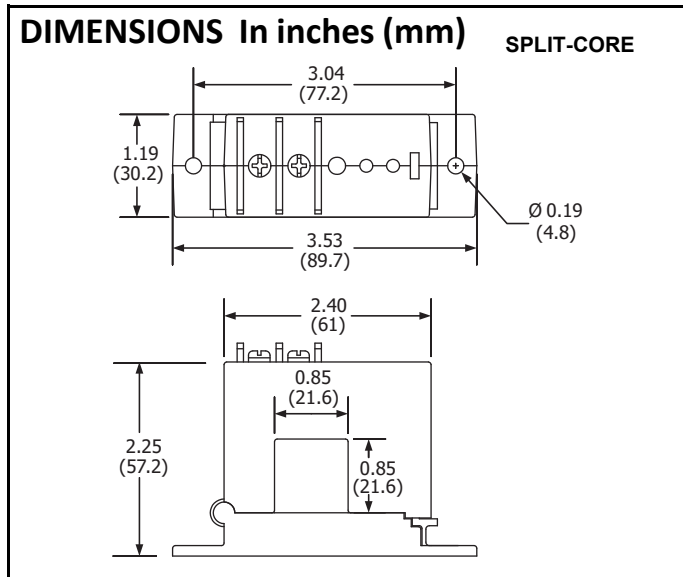

- ISOLATION VOLTAGE:** 3 kV
- CASE:** UL 94V-0 Flammability rated thermoplastic
- ENVIRONMENTAL:** -4 to 122 °F (-20 to 50 °C)
0-95% RH, non-condensing
- TORQUE RATINGS:** 7 in-lbs on Fixed-core models; 9 in-lbs on Split-core models.
- LISTING:** UL Listed: File #E191578.

INSTALLATION

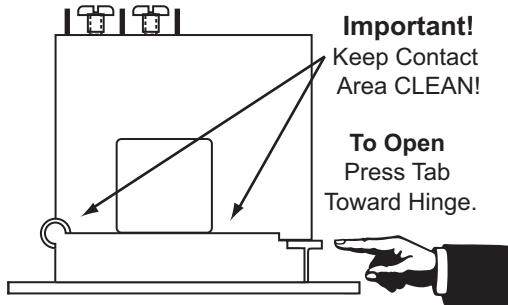

Run wire to be monitored through opening in the sensor. The CTL Series transducers work in the same environment as motors, contactors, heaters, pull-boxes, and other electrical enclosures. They can be mounted in any position or hung directly on wires with a wire tie. Just leave at least one inch (25.4 mm) distance between sensor and other magnetic devices.

Split-Core Versions

Press the tab in the direction as shown to open the sensor. After placing the wire in the opening, press the hinged portion firmly downward until a definite click is heard and the tab pops out fully.

KEEP SPLIT-CORE SENSORS CLEAN.

Silicone grease is factory applied on the mating surfaces to prevent rust and improve performance. Be careful not to allow grit or dirt onto the grease in the contact area. Operation can be impaired if the mating surfaces do not have good contact. Check visually before closing.

OUTPUT WIRING

Connect control or monitoring wires to the sensor. Use up to 14 AWG copper wire and tighten terminals to 7 inch-pounds torque for solid-core models and 9 inch-pounds torque for split-core models. Be sure the output load or loop power requirements are met (see diagram).

POWER SUPPLY

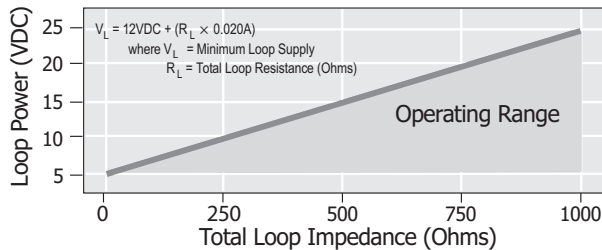

CONNECTIONS

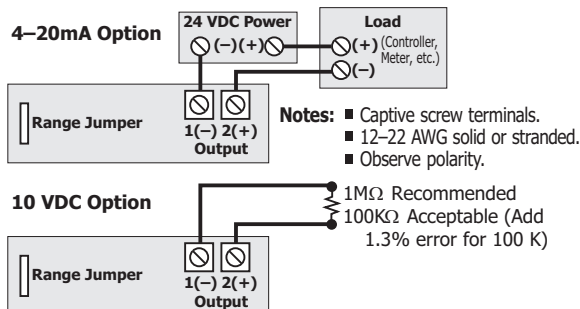

RANGE SELECT

CTL series transducers feature field selectable ranges. The ranges are factory calibrated, eliminating time consuming and inaccurate field setting of zero or span.

1. Determine the normal operating amperage of your monitored circuit
2. Select the range that is equal to or slightly higher than the normal operating amperage.
3. Place the range jumper in the appropriate position.

TROUBLE SHOOTING

0-10 VDC OUTPUT MODELS

1. Sensor Has No Output

- A. Polarity is not properly matched. Check and correct wiring polarity.
- B. Monitored load is not AC or is not on. Check that the monitored load is AC and that it is actually on.
- C. Split Core models: The core contact area may be dirty. Open the sensor and clean the contact area.

2. Output Signal Too Low

- A. The jumper may be set in a range that is too high for current being monitored. Move jumper to the correct range.
- B. Output load too low. Check output load, be sure that it is at least 100K Ω and preferably 1 M Ω .
- C. Monitored current is below minimum required. Loop the monitored wire several times through the aperture until the "sensed" current rises above minimum. Sensed Amps = (Actual Amps) x (Number of Loops). Count loops on the inside of the aperture.

3. Output Signal Is Always At Maximum

- A. Monitored load is not AC or is not on. Check that the monitored load is AC and that it is actually on.

4-20 mA OUTPUT MODELS

1. Sensor Has No Output

- A. Power supply is not properly sized. Check power supply voltage and current rating.
- B. Polarity is not properly matched. Check and correct wiring polarity
- C. Split Core models: The core contact area may be dirty. Open the sensor and clean the contact area.

2. Output Signal Too Low

- A. The jumper may be set in a range that is too high for current being monitored. Move jumper to the correct range.
- B. The load current is not sinusoidal.
- C. Monitored current is below minimum required. Loop the monitored wire several times through the aperture until the "sensed" current rises above minimum. Sensed Amps = (Actual Amps) x (Number of Loops). Count loops on the inside of the aperture.

3. Sensor Is Always At 4 mA

- A. Monitored load is not AC or is not on. Check that the monitored load is AC and that it is actually on.

4. Output Signal Is Always At 20 mA

- A. The jumper may be set in a range that is too low for current being monitored. Move jumper to the correct range.

ORDERING INFORMATION

TYPE	MODEL NO.	DESCRIPTION	PART NUMBER
SPLIT CORE	CTL12S	2-5 A / 4-20 mA	CTL0052S
	CTL52S	10-50 A / 4-20 mA	CTL0502S
	CTL22S	100-200 A / 4-20 mA	CTL2002S
FIXED CORE 4-20 mA	CTL52F	10-50 A / 4-20 mA	CTL0502F
	CTL22F	100-200 A / 4-20 mA	CTL2002F
FIXED CORE 0-10 VDC	CTL51F	10-50 A / 10 VDC	CTL0501F
	CTL21F	100-200 A / 10 VDC	CTL2001F