

## MODEL RLY7 - THREE PHASE DIN RAIL MOUNT SOLID STATE RELAY

- INTEGRATED HEAT SINK
- OPTICALLY ISOLATED
- SOLID STATE SWITCHING
- 25 A THREE PHASE OUTPUT RATING
- 24 TO 660 VAC SWITCHING
- 4 TO 32 VDC CONTROL SIGNAL
- ZERO VOLTAGE TURN-ON
- MOUNTS ON DIN RAIL OR DIRECTLY TO PANEL
- 4000 VOLT ISOLATION
- BUILT-IN SNUBBER
- LED "ON" INDICATOR
- CAGE CLAMP TERMINATIONS



**UL** Recognized Component,  
 File #E191578

### GENERAL DESCRIPTION

The RLY7 is a three phase solid state relay that switches load currents up to 25 A. The unit features a zero voltage turn-on detector to minimize radiated RFI when switching. An internal snubber guards against false triggering of the output related to high dv/dt applications. A low level DC control signal of 4 to 32 VDC is all that is needed for the switching operation. This unit, highlighted by the inverse-parallel SCR output, provides a greatly increased operational life over a mechanical relay by avoiding the usual relay contact problems such as: arcing, bouncing, and mechanical failure.

The RLY7 can be directly controlled by logic/SSR drive output or sourcing output of Red Lion Controls products.

### SAFETY SUMMARY

All safety related regulations, local codes and instructions that appear in the literature or on equipment must be observed to ensure personal safety and to prevent damage to either the instrument or equipment connected to it. If equipment is used in a manner not specified by the manufacturer, the protection provided by the equipment may be impaired.

Do not use this unit to directly command motors, valves, or other actuators not equipped with safeguards. To do so, can be potentially harmful to persons or equipment in the event of a fault to the unit.

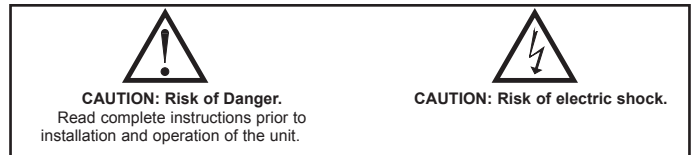

### SPECIFICATIONS

#### OUTPUT SPECIFICATIONS

1. Operating Voltage Range: 24 to 660 VAC
2. Operating Frequency Range: 47 to 63 Hz
3. Maximum Continuous Load Current: 25 Amps (3 pole), 35 Amps (2 pole)  
(See Safe Operating Conditions)
5. Min. Load Current: 100 mA
6. Leakage Current @  $V_{OUT}$  (Max.): 10 mA
7. Peak Blocking Voltage: 1400 VAC
8. Voltage Drop @  $I_{OUT}$ : 3 VAC
9.  $I^2T$  Fusing: 1350 A<sup>2</sup>sec  
(For Fusing Purposes, T = 8.3 msec.)
10. Dv/dt @  $V_{OUT}$  (Max.): 1000 V/ $\mu$ sec

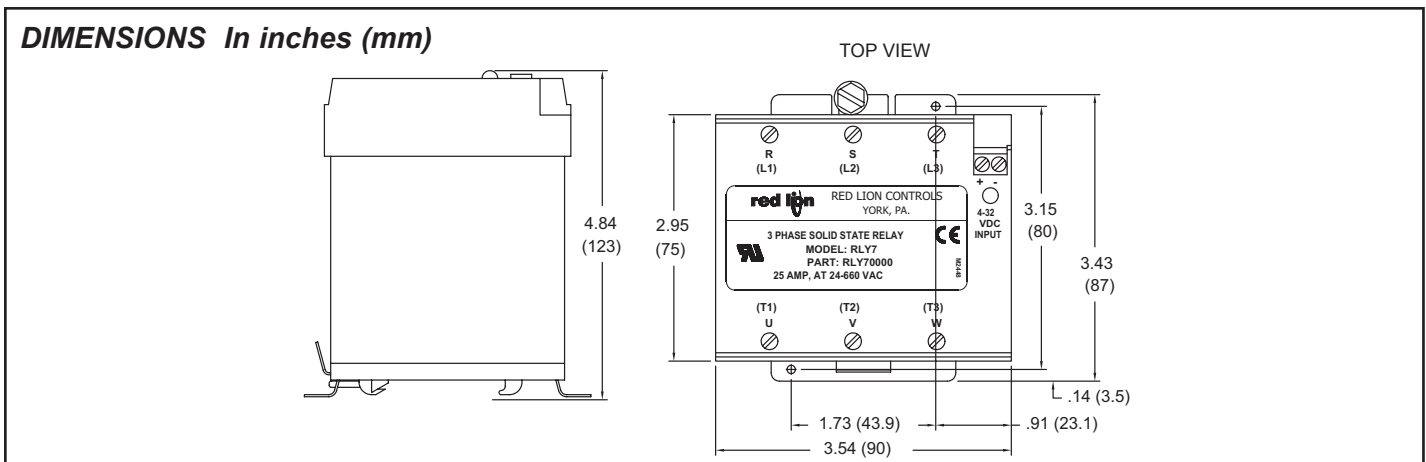

## INPUT SPECIFICATIONS

1. Control Voltage Range: 4 to 32 VDC
2. Turn-on Voltage (Min.): 4 VDC
3. Turn-off Voltage (Max.): 1 VDC
4. Input Current (Max.): 15 mA

## GENERAL SPECIFICATIONS

1. Isolation (Input to Output to Base): 4000 V<sub>RMS</sub>
2. Operating Temperature Range: 0°C to 40°C

## SAFE OPERATING CONDITIONS

The relay must always operate within the “Safe Operating Area” of the Derating Curve Figure. Operations outside the Safe Operating Area will shorten the life of, or cause permanent damage to, the relay. The ambient temperature should be measured 1" (25 mm) below the relay (when mounted to a vertical surface) and with all of the associated equipment operating.

It is strongly recommended that a 1" (25 mm) clearance is maintained on all four sides of the relay. If the relays are mounted against each other, then the end relays must be derated by an additional 10% (of the Derating Curve) and the middle relays by 20%.

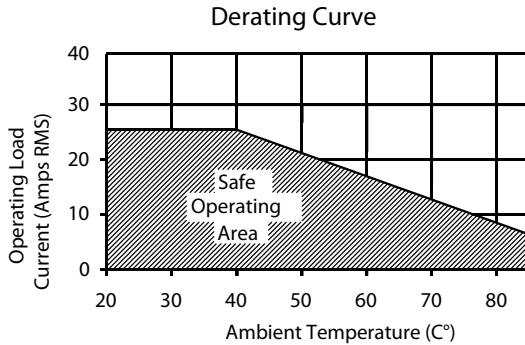

In small enclosures, adequate ventilation must be provided to assure proper safe operating temperature. Accumulation of dust and dirt on the heat sink fins will also affect heat dissipation. In extreme dust and dirt conditions, the relay must be derated by an additional 20%.

## SCHEMATIC

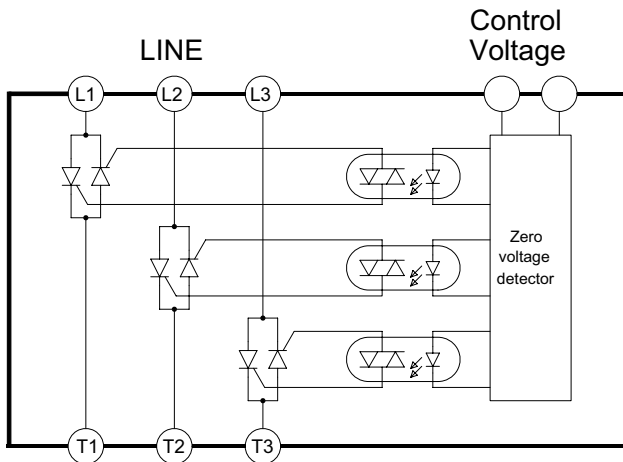

## ORDERING INFORMATION

MODEL NO.	DESCRIPTION	PART NUMBER
RLY7	Three Phase Din Rail Mount Solid State Relay	RLY70000



Do not dispose of unit in trash - Recycle

## FUSING

Devices such as electromechanical circuit breakers and slow blow fuses cannot react quickly enough to protect this relay in a shorted condition. Fast “semiconductor fuses” with appropriate I<sup>2</sup>T ratings are strongly recommended.

## MECHANICAL INTERRUPT SWITCH

The off-state leakage current of the power unit is 10 mA maximum. The voltage level of the output will rise proportional to the resistance of the load due to this leakage current. Full line voltage can be measured when the output is connected to a high resistance load and the power unit is in the off-state.

A mechanical interrupt switch is recommended between the line voltage and the load. The switch should be opened when servicing any part of the output wiring. When measuring the off-state output voltage of the unit for correct operation, load the output of the RLY7 with a small resistance (approximately 100 ohms).

## WIRING GUIDELINES

The controlling device and the relay load should NEVER share the same power feed. It is recommended that this relay be installed as close as possible to the load to keep the power cable runs short. The control voltage can run over distances in excess of 200 feet with shielded cable. If using shielded cable, connect the shield to the minus “-” terminal of the control signal at one end only.

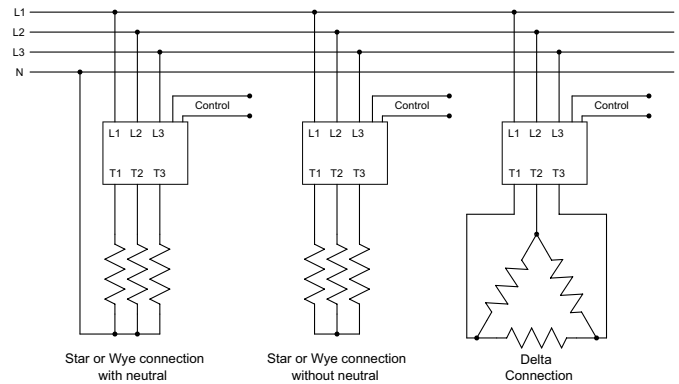

## THREE PHASE HEATING APPLICATION

This application shows a Model TCU Temperature Controller regulating the temperature of a drying kiln. The TCU has an SSR Drive Output Module installed. This module controls the three phase relay directly.

