

**600 Series
Industrial
Ethernet
Switches**

**Hardware
Installation
Guide**



Industrial Ethernet Switch Installation Guide

- 604MFX-ST**
- 604MFXE-ST-15**
- 604MFXE-ST-40**
- 604MFXE-ST-80**
- 608MFX-ST**
- 608MFXE-ST-15**
- 608MFXE-ST-40**
- 608MFXE-ST-80**





Copyright, © N-TRON Corp., 2008
820 S. University Blvd., Suite 4E
Mobile, AL USA 36609

All rights reserved. Reproduction, adaptation, or translation without prior written permission from N-TRON Corp. is prohibited, except as allowed under copyright laws.

Ethernet is a registered trademark of Xerox Corporation. All other product names, company names, logos or other designations mentioned herein are trademarks of their respective owners.

The information contained in this document is subject to change without notice. N-TRON Corp. makes no warranty of any kind with regard to this material, including, but not limited to, the implied warranties of merchantability or fitness for a particular purpose. In no event shall N-TRON Corp. be liable for any incidental, special, indirect, or consequential damages whatsoever included but not limited to lost profits arising out of errors or omissions in this manual or the information contained herein.

Warning

Do not perform any services on the unit unless qualified to do so. Do not substitute unauthorized parts or make unauthorized modifications to the unit.

Do not operate the unit with the top cover removed, as this could create a shock or fire hazard.

Do not block the air vents on the sides or the top of the unit.

Do not operate the equipment in the presence of flammable gasses or fumes. Operating electrical equipment in such an environment constitutes a definite safety hazard.

Safety Warnings

ELECTRICAL SAFETY



WARNING: Disconnect the power cable before removing the enclosure top.

WARNING: Do not operate the unit with the top cover removed.

WARNING: Properly ground the unit before connecting anything else to the unit. Units not properly grounded may result in a safety risk and could be hazardous and may void the warranty. See the grounding technique section of this user manual for proper ways to ground the unit.

WARNING: Do not work on equipment or cables during periods of lightning activity.

WARNING: Do not perform any services on the unit unless qualified to do so.

WARNING: Do not block the air vents.

WARNING: Observe proper DC Voltage polarity when installing power input cables. Reversing voltage polarity can cause permanent damage to the unit and void the warranty.

LASER SAFETY (604/608MFXE Version Only)



CAUTION: CLASS 1 LASER PRODUCT.
Do not stare into the laser!)

600 Series Industrial Ethernet Switch

The N-TRON 600 Series are product derivatives of the OSM/ESM family jointly manufactured by Siemens and N-TRON. The N-TRON 600 Series switches supports high speed layer 2 switching between ports, and is housed in a ruggedized steel enclosure, and can withstand industrial temperatures, as well as high shock & vibration, and carries an MTBF in excess of 1M hours.

The 604MFX (608MFX) is a 4 (8) port ruggedized Ethernet switch that is capable of auto negotiating 10/100 Mb and half/full duplex communications on 2 (6) copper ports, and contains two 100BaseFX Fiber Optic ports.

The 604/608MFX are managed switches that supports SNMP management software, as well as configuration by a CLI (Command Line Interface – Serial Port), Telnet, and/or Web based browsers.

The 600 Series Switches can also serve as redundancy managers, detect faults in ring topologies and allow high-speed ring network healing, thus providing media redundancy for mission critical control applications.

Key Features

- Full Managed Solution
- Supports Web Based Management
- 802.1P QOS (Quality of Service) Supported
- Port Mirroring supported
- Supports Media Redundant Fiber Ring Topology
- Full IEEE 802.3 & 100BASE-FX Compliance
- Extended Environmental Specifications
- Support for Full/Half Duplex Operation
- Auto Sensing Speed and Flow Control
- Industry Standard 35mm DIN-Rail Enclosure
- Fully Redundant Isolated DC Power Inputs

PACKAGE CONTENTS

Please make sure the Ethernet Switch package contains the following items:

1. 600 Series Ethernet Switch
2. Product CD

Contact your carrier if any items are damaged.

INSTALLATION

Read the following warning before beginning the installation:

WARNING



The FXE units contain a class 1 laser. Do not stare into the laser beam (fiber optic connector) when installing or operating the product.



Never install or work on electrical equipment or cabling during periods of lightning activity. **NO USER SERVICABLE PARTS INSIDE.**

Disconnect the power cable before removing the enclosure top.
Do not operate the unit with the top cover removed

UNPACKING

Remove all the equipment from the packaging, and store the packaging in a safe place.

File any damage claims with the carrier.

600 Series Hazardous Location Installation Requirements

1. **WARNING!** Do not disconnect while circuit is live, unless area is known to be non-hazardous.
2. **WARNING!** Install only in accordance with Local & National Codes of .Authorities Having Jurisdiction.
3. Class I, Div 2 installation requires that all devices connected to this product must be approved for the area in which it is installed.
4. Only hazardous location approved wiring with temperature ratings greater than 80 C permitted for Class I, Div 2 installations operating at temperatures up to 60 C ambient.

Personnel Qualification Requirements

Only qualified personnel should be allowed to install and work on this equipment. Qualified personnel are defined as individuals who are familiar with the installation, assembly, startup, and operation of this product and who possess the relevant qualifications for their work e.g.:

- Training in or authorization for connecting up, grounding, or labeling circuits and devices or systems in accordance with current standards in safety technology.
- Training in or authorization for the maintenance and use of suitable safety equipment in accordance with current standards in safety technology.
- First aid qualification.

DIN-Rail Mounting

Install the unit on a standard 35mm Din-Rail. When installing the unit in an enclosed cabinet, recess it to allow at least 3” of clearance for fiber optic cable bend radius, and 2 inches for TX cables and power connections. Please note the 600 Series units must be installed in the vertical orientation for cooling purposes. In this orientation, the power connector is at the top of the unit, and the signal cables exit from the bottom of the unit.

19” Rack Mounting

19” Rack mount kits are available. Please consult with your local sales representative for price & availability. Order part number: URMK

APPLYING POWER

1. Unscrew the flange & remove the DC Voltage Input Plug from the Header.
2. Install the DC Power Cables into the Plug(s) (observing polarity per the legend on the top of the unit). L1+ and L2+ are the +24V connections. M1 and M2 are the minus (-) returns for the L1 and L2 respectively. F1 and F2 terminals are across the contact switch that opens to signify a fault detection. Voltage/Current for F1/F2 is limited to 24V @ 100mA.
3. Plug the Voltage Input Plug back into the side header. All LED's will flash ON Momentarily.
4. Tightening torque for the terminal block power plug is **0.5 Nm/0.368 Pound Foot**.
5. The unit will complete the power up cycle in approximately 20 seconds.

Note: Only 1 power supply is required to be connected to power for minimal operation. For redundant power operation, L1 and L2 terminals must be connected to separate DC Voltage sources. Use wire sizes 14-28 gauge.

Recommended 24V DC Power Supplies, similar to:

100VAC/240VAC:

N-Tron's NTPS-24-1.3, DC 24V/1.3A

CONNECTING THE STANDARD RING

Remove the dust cap from the fiber optic connectors and connect the fiber optic cables.

Please refer to the Figure 1. Diagram.

To begin the ring, the TX out-port #7 should be connected to the RX in-port #8 of the far end station. The RX in-port #7 should be connected to the TX out-port #8 on the far end station.

Likewise, the TX out-port #8 should be connected to the RX in-port #7 of the far end station completing the ring. The RX in-port #8 should be connected to the TX out-port #7 on the far end station.

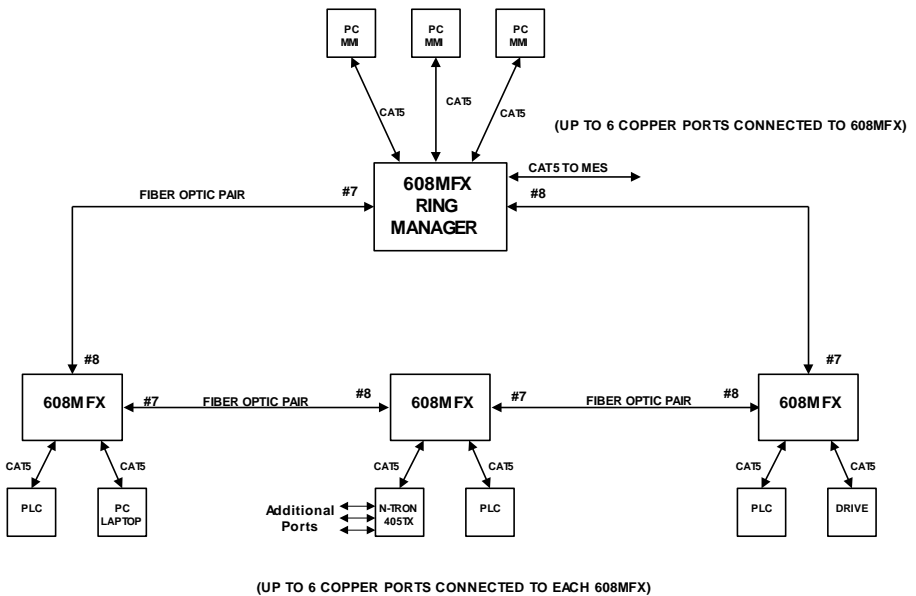

608MFX RING TOPOLOGY
Figure 1

For 10/100 Base-TX ports, plug a Category 5 (or better) twisted pair cable into one of the RJ45 copper ports (1-6). Connect the other end to the far end station. Verify that the Port LED's are ON once the connection has been completed. For Switch to Switch or Switch to Repeater connections, a crossover cable may be required if the connecting unit does not support the HP-MDIX auto cable detect feature. For 10/100BaseTX operation, the 600 Series Switch will sense & adapt accordingly.

A maximum number of 50 600 Series switches can be connected in a single ring.

Warning: In absence of RSTP or Proprietary Ring control on the specific ports connected, creating a port to port connection on the same switch (i.e. a loop) is an illegal operation and will create a broadcast storm which will crash the network!

CONNECTING MULTIPLE RINGS (608MFX Only)

For multiple rings, the connection between two network segments is made on two separate paths. Two of the 608MFX's in a ring are connected together via a connection cable with an ITP cable (maximum length of 40m), and inform each other of their operating states. One of the 608MFX units is assigned the redundant function using the DIP switch setting "Stby on" (Standby Slave). The other 608MFX unit takes over the function of the Standby Master, with the DIP switch setting "Stby off" (see Figure 2). **Please note that 604MFX units cannot be used as Ring Couplers.**

Because of the 50-unit ring limit, for larger networks, the user must configure multiple rings. By using the Master/Slave Standby approach to couple rings together, the user can enlarge the network by chaining segments.

Port Assignment in the Standby Mode

On the Standby Master and Standby Slave only port #1 (default standby port) can be used for the coupling to the neighboring ring. Connect the #1 ports together using a CAT5E crossover cable between switches. Ports 2-6 can be used just as normal switch ports.

Simultaneous Standby and Redundancy Manager Operation

A standby master or standby slave can adopt the function of a redundancy manager at the same time.

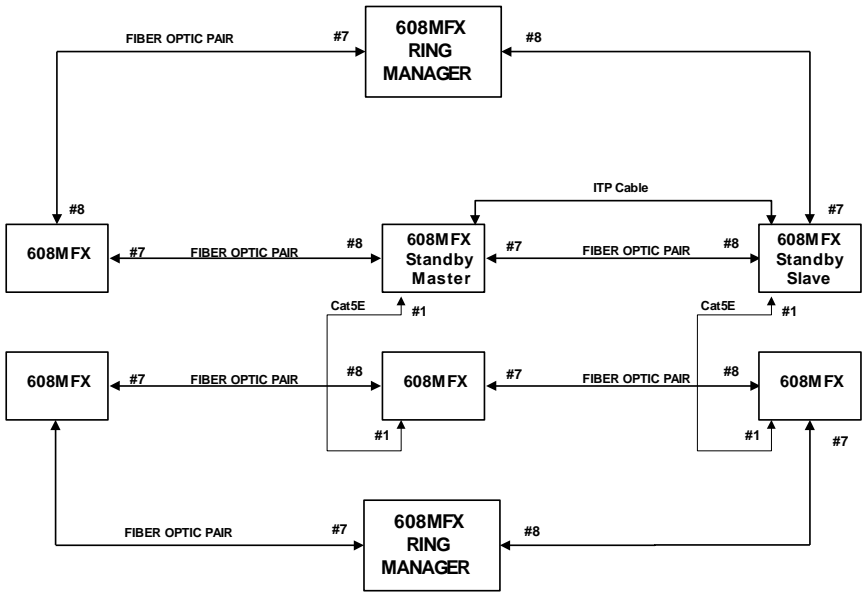

**608MFX Network Segment Redundancy
Figure 2**

Replacing the Standby Master during operation

When replacing a standby master during operation, the following procedure is necessary to prevent an interruption on the network.

1. Remove the terminal block for power supply to the standby master.
2. Remove the signal lines and the standby connecting cable from the standby master.
3. Connect the signal lines to the replacement device.
4. Plug the power terminal block into the replacement device.

When replacing the standby slave, no special steps are necessary.

DISPLAYS AND OPERATING CONTROLS

LED's

Fault (red LED)

Status	Meaning
ON	The 604/608MFX has detected an error. The signaling contact opens at the same time.
OFF	No errors detected by the 604/608MFX.

Stby - Standby (green LED, 608MFX Only)

Status	Meaning
ON	The 608MFX standby function is activated, indicating the 608MFX is in the standby passive mode.
OFF	The standby function is deactivated.
Flashing	The 608MFX standby function is activated, indicating the 608MFX is in the active mode. In other words, the Ring master has failed and the standby takes over the data traffic.

RM - Redundancy Manager (green LED)

Status	Meaning
ON	The 604/608MFX is operating in the redundancy manager mode. The ring is operating free of errors, as monitored by the redundancy manager. Note: One (and only one) 600 Series Switch must operate as the redundancy manager in each ring.
OFF	The 608MFX is not operating in the redundancy manager mode.
Flashing	The redundancy manager has detected a break in the ring. The 608MFX makes the connection between its two ring ports so that a functional bus configuration is re-established within 300 ms.

Port LED's

The display Mode is indicated by the LED pair labeled “Display Mode”, and the state is given by the legend on the front of the 600 Series Switch. To transition between these Display Modes, the Select/Set button must be pressed briefly (similar to left mouse click). The four states are: Port Status, 100Mbit/s, Full Duplex, Fault Mask.

Display Mode: State = Port Status	Meaning
OFF	No Valid Connection to the port.
Green	Valid Connection to the port (good link). Flashes green once per cycle, port switched to standby Flashes green three time per cycle, port is disabled by configuration
Yellow	Indicates Port is actively receiving data

Display Mode: State = 100 Mbps	Meaning
OFF	Port operating at 10 Mbps
Green	Port operating at 100 Mbps

Display Mode: State = Full Duplex	Meaning
OFF	Port operating half duplex
GREEN	Port operating full duplex

Display Mode: State = Fault Mask	Meaning
OFF	Port is not currently monitored
Green	Port is currently monitored

“Select/Set” Button

The Select/Set” multi-functional button on the front panel of the 604/608MFX performs the following actions:

- Pressing the button briefly (similar to left mouse click) transitions the display of the two display mode LED’s. The current display mode is indicated by the status of the display mode LED’s per the legend definition on the front of the switch.
- If the Display Mode is currently selecting port status (all Display Mode LEDs off) and if the button is pressed for three seconds, the Display Mode LEDs begin to flash. If you then continue to press the button for a further two seconds, the switch is reset. When the 600 series switch is reset, all the settings return to their defaults (as set in the factory). This allows you to cancel settings made from the Web based management tools, Telnet, or the command line configurator (serial port), or the fault mask.
- If the Display Mode is currently selecting the fault status and you press the button for two seconds, the display LED’s start to flash. If you then continue pressing the button for another two seconds, the current status of the ports and the supply voltage are entered in the fault mask. Any change in their status after the fault mask update will create a fault.

Note: Do not press the “Select/Set” button while the unit is powering up. In the event that the “Select/Set” button was pressed while the switch is starting up (approximately a 20-second window), all display mode LEDs will flash simultaneously. This mode is exited by pressing the button again after the unit has completely powered up (a 20-second delay).

Aging Time

The 604/608MFX monitors the age of the addresses it has learnt, and addresses that exceed a certain age (aging time, default setting = 40 sec), are deleted again by the switch. If a packet with a source address matching the address entry is received before the aging time elapses, the address entry is retained, and the age is reset. If a packet is received and there is no address entry for the source address, it is learnt. If a packet is received and there is no address entry for the destination address, it is sent to all ports.

IEEE 802.1Q, VLAN

The 600 Series switches do not support VLAN tags according to IEEE 802.1Q. Users must configure their networks so that no VLAN packets are sent.

IEEE 802.1P, QOS

The 600 Series does support QOS. Users should configure their networks such that no packets with a priority tag higher than 3 are transmitted since these packets can influence redundancy functions (for example, longer switchover times if a fault develops, or false fault detection).

Two-Pin Dip Switch Setting

With the two-pin DIP switch on the upper casing of the 604/608MFX, you can do the following:

- With the **Stby** button, you can activate the standby function of the device (608 only). This switch is not connected in the 604MFX.
- With the **RM** switch, you can activate the redundancy manager function of the device.

Note: The switch must be restarted after changing the DIP switch Settings. The switch settings are only adopted when the device powers Up.

Serial Interface

The 604/608MFX provides an EIA-232 interface accessed via a 9 pin male connector (labeled V24 on the unit). This is used to access the Command Line Interpreter (CLI). Functions include setting the IP address, and other parameters (see Network Management Users guide). The pin-outs are shown below:

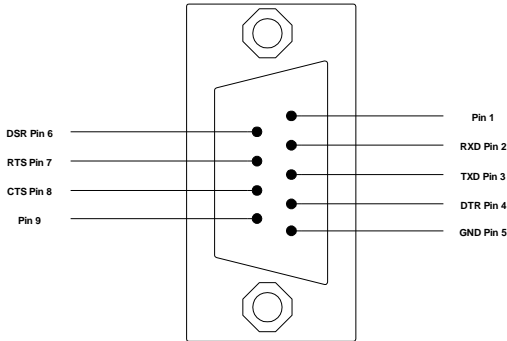

Standby-Sync Port (608MFX Only)

A 9-pin female connector is used to connect the standby unit to the redundancy manager for redundant standby coupling. The casing of the connector is electrically connected to the chassis of the switch

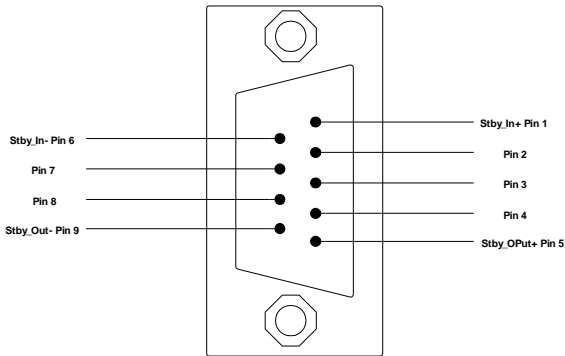

Serial Cable

Connect the serial COM port of your PC and the 600 Series Switch using a normal null modem cable (or a straight through cable with a null modem adapter). You will require a cable with a 9-pin or 25-pin sub-D female connector for the PC end, and a 9-pin female sub-D connector for the 608MFX end.

The following table shows the pin-out and the connections for both types of cable:

PC Port	25-Pin Female	9-Pin Female	604/608MFX 9-Pin Female	
Signal Name	Pin #	Pin #	Pin #	Signal Name
TXD	2	3	2	RXD
RXD	3	2	3	TXD
RTS	4	7	8	CTS
CTS	5	8	7	RTS
GND	7	5	5	SG
DSR	6	6	4	DTR
DTR	20	4	6	DSR

Shielded cables and null modems are readily available from Radio Shack or a variety of computer shops.

Hyperterminal

The following configuration should be used in Hyperterminal:

Port Settings: 115200
Data Bits: 8
Parity: None
Stop bits: 1
Flow Control: None

TROUBLESHOOTING

1. Make sure the Power LED (L1 and/or L2) is ON.
2. Make sure the Voltage is within specifications (18-32V@1A).
3. Make sure the fiber ports and TX ports are properly connected.
4. Verify that Port LED's are ON for connected ports.
5. Verify the status of the fault (RM) LED.
6. Verify cabling (pin-outs & integrity).
7. Verify that cabling is Category 5 (or higher) for 100Mbit TX Operation, 62.5/125 m @ 1300nm for 100 Mbit FX Operation.
8. Verify TX port #7 is connected to RX port #8 (and vice versa).
9. Verify that only one 600 series switch is in RM (redundancy manager) mode.

FCC STATEMENT

This product complies with Part 15 of the FCC-A Rules.

Operation is subject to the following conditions:

- (1) This device may not cause harmful Interference
- (2) This device must accept any interference received, including interference that may cause undesired operation.

KEY SPECIFICATIONS

Physical

Height:	5.5"	(13.65 cm)
Width:	8.55"	(21.70 cm)
Depth:	2.75"	(6.90 cm)
Weight:	3.08 lbs	(1.4 kg)

Electrical

Input Voltage:	18-32 VDC (Redundant inputs)
Input Current:	1.0A @ 24VDC
Inrush Current:	10.5A / 7 ms @ 24VDC
Power Consumption:	24 Watts @24V
Input Ripple:	Less than 100 mV

Environmental

Operating Temperature:	0°C to 60°C
Storage Temperature:	-40°C to 80°C
Operating Humidity: (Non Condensing)	10% to 95%
Operating Altitude:	0 to 6,500 ft.

Shock and Vibration

Shock:	200g @ 10ms
Vibration:	1g, 10-500Hz,
Seismic:	20g, 5-200Hz, 15s, 3 axis

Reliability

MTBF:	>1M Hours (measured)
-------	----------------------

Network Media

10BaseT:	Category-3,4,5 Cable
100BaseT:	Category 5 or higher Cable
100Base FX:	62.5/125um Fiber @1300nm or 50/125um Fiber @1300nm

Fiber Transceiver Characteristics

Fiber Length:	2km*	15km**	40km**	80km**
TX Power Min	-19dBm	-15dBm	-5dBm	-5dBm
RX Sensitivity Max:	-31dBm	-31dBm	-34dBm	-34dBm
Wavelength:	1310nm	1310nm	1310nm	1550nm

*=Multimode

** =Singlemode

Recommended Wiring Clearance:

Top: 1 " (2.54 cm)

Front: 4 " (10.16 cm)

Emissions and Safety Approvals:

FCC Part 15 Class A CE, UL, FM Class 1 Div 2 Groups A,B,C,D

Note: Shielded cables must be used to meet emission standards.

DNV/Det Norske Veritas (A-10136)

Ordering Information

PN	Description
604MFX-ST 608MFX-ST	Industrial Ethernet Switch, ST Fiber Connectors, MM, 2km
604MFXE-ST-YY 608MFXE-ST-YY	Industrial Ethernet Switch, ST Fiber Connectors, Singlemode
Where:	YY = -15, -40, or -80km
URMK	19" Rack Mount Kit
SDP1	Din Rail Power Supply 111-220VAC input 24VDC@1.3A

Warranty: Effective January 1, 2008, all N-TRON products carry a 3 year limited warranty from the date of purchase.

Contact/Support Information

N-TRON Corp
820 S. University Blvd., Suite 4E,
Mobile, AL 36609
TEL: (251) 342-2164
FAX: (251) 342-6353
Website: www.n-tron.com
E-mail: N-TRON_Support@n-tron.com

N-TRON Limited Warranty

N-TRON, Corp. warrants to the end user that this hardware product will be free from defects in workmanship and materials, under normal use and service, for the applicable warranty period from the date of purchase from N-TRON or its authorized reseller. If a product does not operate as warranted during the applicable warranty period, N-TRON shall, at its option and expense, repair the defective product or part, deliver to customer an equivalent product or part to replace the defective item, or refund to customer the purchase price paid for the defective product. All products that are replaced will become the property of N-TRON. Replacement products may be new or reconditioned. Any replaced or repaired product or part has a ninety (90) day warranty or the remainder of the initial warranty period, whichever is longer. N-TRON shall not be responsible for any custom software or firmware, configuration information, or memory data of customer contained in, stored on, or integrated with any products returned to N-TRON pursuant to any warranty.

OBTAINING WARRANTY SERVICE: Customer must contact N-TRON within the applicable warranty period to obtain warranty service authorization. Dated proof of purchase from N-TRON or its authorized reseller may be required. Products returned to N-TRON must be pre-authorized by N-TRON with a Return Material Authorization (RMA) number marked on the outside of the package, and sent prepaid and packaged appropriately for safe shipment. Responsibility for loss or damage does not transfer to N-TRON until the returned item is received by N-TRON. The repaired or replaced item will be shipped to the customer, at N-TRON's expense, not later than thirty (30) days after N-TRON receives the product. N-TRON shall not be responsible for any software, firmware, information, or memory data of customer contained in, stored on, or integrated with any products returned to N-TRON for repair, whether under warranty or not.

ADVANCE REPLACEMENT OPTION: Upon registration, this product qualifies for advance replacement. A replacement product will be shipped within three (3) days after verification by N-TRON that the product is considered defective. The shipment of advance replacement products is subject to local legal requirements and may not be available in all locations. When an advance replacement is provided and customer fails to return the original product to N-TRON within fifteen (15) days after shipment of the replacement, N-TRON will charge customer for the replacement product, at list price.

WARRANTIES EXCLUSIVE: IF AN N-TRON PRODUCT DOES NOT OPERATE AS WARRANTED ABOVE, CUSTOMER'S SOLE REMEDY FOR BREACH OF THAT WARRANTY SHALL BE REPAIR, REPLACEMENT, OR REFUND OF THE PURCHASE PRICE PAID, AT N-TRON'S OPTION. TO THE FULL EXTENT ALLOWED BY LAW, THE FOREGOING WARRANTIES AND REMEDIES ARE EXCLUSIVE AND ARE IN LIEU OF ALL OTHER WARRANTIES, TERMS, OR CONDITIONS, EXPRESS OR IMPLIED, EITHER IN FACT OR BY OPERATION OF LAW, STATUTORY OR OTHERWISE, INCLUDING WARRANTIES, TERMS, OR CONDITIONS OF MERCHANTABILITY, FITNESS FOR A PARTICULAR PURPOSE, SATISFACTORY QUALITY, CORRESPONDENCE WITH DESCRIPTION,

AND NON-INFRINGEMENT, ALL OF WHICH ARE EXPRESSLY DISCLAIMED. N-TRON NEITHER ASSUMES NOR AUTHORIZES ANY OTHER PERSON TO ASSUME FOR IT ANY OTHER LIABILITY IN CONNECTION WITH THE SALE, INSTALLATION, MAINTENANCE OR USE OF ITS PRODUCTS. N-TRON SHALL NOT BE LIABLE UNDER THIS WARRANTY IF ITS TESTING AND EXAMINATION DISCLOSE THAT THE ALLEGED DEFECT OR MALFUNCTION IN THE PRODUCT DOES NOT EXIST OR WAS CAUSED BY CUSTOMER'S OR ANY THIRD PERSON'S MISUSE, NEGLIGENCE, IMPROPER INSTALLATION OR TESTING, UNAUTHORIZED ATTEMPTS TO OPEN, REPAIR OR MODIFY THE PRODUCT, OR ANY OTHER CAUSE BEYOND THE RANGE OF THE INTENDED USE, OR BY ACCIDENT, FIRE, LIGHTNING, POWER CUTS OR OUTAGES, OTHER HAZARDS, OR ACTS OF GOD.

LIMITATION OF LIABILITY: TO THE FULL EXTENT ALLOWED BY LAW, N-TRON ALSO EXCLUDES FOR ITSELF AND ITS SUPPLIERS ANY LIABILITY, WHETHER BASED IN CONTRACT OR TORT (INCLUDING NEGLIGENCE), FOR INCIDENTAL, CONSEQUENTIAL, INDIRECT, SPECIAL, OR PUNITIVE DAMAGES OF ANY KIND, OR FOR LOSS OF REVENUE OR PROFITS, LOSS OF BUSINESS, LOSS OF INFORMATION OR DATA, OR OTHER FINANCIAL LOSS ARISING OUT OF OR IN CONNECTION WITH THE SALE, INSTALLATION, MAINTENANCE, USE, PERFORMANCE, FAILURE, OR INTERRUPTION OF ITS PRODUCTS, EVEN IF N-TRON OR ITS AUTHORIZED RESELLER HAS BEEN ADVISED OF THE POSSIBILITY OF SUCH DAMAGES, AND LIMITS ITS LIABILITY TO REPAIR, REPLACEMENT, OR REFUND OF THE PURCHASE PRICE PAID, AT N-TRON'S OPTION. THIS DISCLAIMER OF LIABILITY FOR DAMAGES WILL NOT BE AFFECTED IF ANY REMEDY PROVIDED HEREIN SHALL FAIL OF ITS ESSENTIAL PURPOSE.

DISCLAIMER: Some countries, states, or provinces do not allow the exclusion or limitation of implied warranties or the limitation of incidental or consequential damages for certain products supplied to consumers or the limitation of liability for personal injury, so the above limitations and exclusions may be limited in their application to you. When the implied warranties are not allowed to be excluded in their entirety, they will be limited to the duration of the applicable written warranty. This warranty gives you specific legal rights which may vary depending on local law.

GOVERNING LAW: This Limited Warranty shall be governed by the laws of the State of Delaware, U.S.A.