

MODEL CX200 - PARADIGM 4 X 20 VFD OPERATOR TERMINAL



- 4 LINE X 20 CHARACTER VACUUM FLUORESCENT DISPLAY
- 500 ALARM POINT LOGGER
- RECIPE HANDLING
- COMPREHENSIVE REPORT GENERATION
- UNLIMITED PASSWORD PROTECTION
- REAL TIME CLOCK, BATTERY BACKED
- EXPRESSION EVALUATION
- 32 BIT / FLOATING POINT MATH
- DIRECT, NETWORK (Including Multiple protocol) OR MODEM LINK TO PLC
- NEMA 4/IP65



FOR USE IN HAZARDOUS LOCATIONS:
 Class I, Division 2, Groups A, B, C, and D
 Class II, Division 2, Groups F and G
 Class III, Division 2

DESCRIPTION

The CX200 from the Paradigm Range of operator interfaces meets the ever increasing demands of industry for powerful easy-to-use terminals. Both hardware and software are designed to allow the user to easily upgrade and take full advantage of our continuing development and improvements to our products.

SAFETY SUMMARY

All safety related regulations, local codes and instructions that appear in the manual or on equipment must be observed to ensure personal safety and to prevent damage to either the instrument or equipment connected to it. If equipment is used in a manner not specified by the manufacturer, the protection provided by the equipment may be impaired.

Do not use this unit to directly command motors, valves, or other actuators not equipped with safeguards. To do so, can be potentially harmful to persons or equipment in the event of a fault to the unit.



WARNING - EXPLOSION HAZARD - SUBSTITUTION OF COMPONENTS MAY IMPAIR SUITABILITY FOR CLASS I, DIVISION 2 / CLASS II, DIVISION 2 / CLASS III, DIVISION 2



CAUTION: Read complete instructions prior to installation and operation of the unit.

SPECIFICATIONS

- POWER REQUIREMENTS:** 11 to 30 VDC @ 3.2 W
Power Up Current: 2.5 A for 7 msec. max.
 Must use a Class 2 or SELV rated power supply.
- DISPLAY:** 4 lines of 20 characters, 5 mm high Vacuum Fluorescent display
- KEYPAD:** 3 screen legenable soft keys, 8 User re-legendable function keys, numeric pad with raise, lower, next, previous, enter, delete, exit, alarms and mute keys, all embossed with Tactile feedback.
- MEMORY:** 128 K (64 K user) battery backed RAM (Typical battery life 7 years 50/50 on/off cycle). Optional factory fit expansion to 256 K (192 K user).
- CONSTRUCTION:** Steel rear metal enclosure with NEMA 4/IP65 aluminum front plate when correctly fitted with the gasket provided. This unit is rated for NEMA 4/IP65 indoor use. Installation Category I, Pollution Degree 2
- PHYSICAL DIMENSIONS:** L = 8.11" (206 mm), H = 6.89" (175 mm), D = 2.03" (51.6 mm).
- MOUNTING REQUIREMENTS:** Max. panel thickness is 0.375" (9.5 mm). For NEMA 4/IP65 sealing, a steel panel with a minimum thickness of 0.125" (3.175 mm) is recommended.

ORDERING INFORMATION

MODEL NO.	DESCRIPTION	PART NO.
CX200	VFD, 4 X 20, 8 Function keys, 128 K memory	CX200000
	VFD, 4 X 20, 8 Function keys, 256 K memory	CX200010
	Battery Replacement	BAL3R004
	EDICT-97 Development Kit, Includes Software, Manual and 9-pin RS232 Programming Cables	SFEDT
	Communication Cables	P895xxxZ

DIMENSIONS In inches (mm)

Tolerance: ±.010" (±0.25mm)

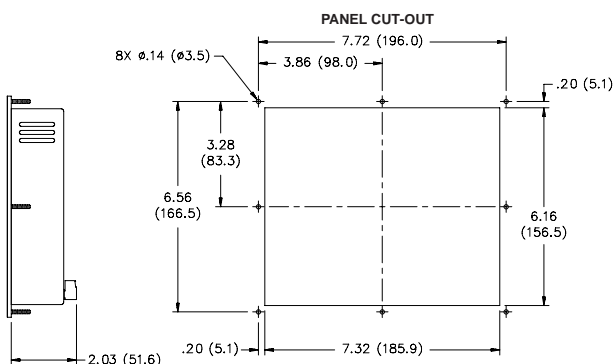
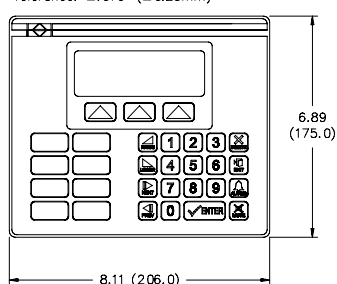

8. CERTIFICATIONS AND COMPLIANCES:

SAFETY

UL Recognized Component, File #E179259, UL3101-1, CSA 22.2 No.1010-1
Recognized to U.S. and Canadian requirements under the Component
Recognition Program of Underwriters Laboratories, Inc
UL Listed, File #E211967, UL3101-1, UL1604, CSA 22.2 No. 1010.1, CSA
22.2 No. 213-M1987
LISTED by Und. Lab. Inc. to U.S. and Canadian safety standards
Type 4 Enclosure rating (Face only), UL50
IECEE CB Scheme Test Certificate #US/5414A/UL
CB Scheme Test Report #01ME18821-10122001
Issued by Underwriters Laboratories Inc.
IEC 1010-1, EN 61010-1: Safety requirements for electrical equipment for
measurement, control, and Laboratory use, Part 1
IP65 Enclosure rating (face only), IEC 529

ELECTROMAGNETIC COMPATIBILITY

Immunity to EN 50082-2

Electrostatic discharge	EN 61000-4-2	Level 2; 4 Kv contact Level 3; 8 Kv air
Electromagnetic RF fields	EN 61000-4-3	Level 3; 10 V/m 80 MHz - 1 GHz
Fast transients (burst)	EN 61000-4-4	Level 4; 2 Kv I/O Level 3; 2 Kv power
RF conducted interference	EN 61000-4-6	Level 3; 10 V/rms ¹ 150 KHz - 80 MHz

Emissions to EN 50081-1

RF interference	EN 55022	Enclosure class B
-----------------	----------	-------------------

1. *Self-recoverable loss of performance during EMI disturbance at 10 Vrms:
Communications error may occur during EMI disturbance.*

For operation without loss of performance:

I/O cables are routed in metal conduit connected to earth ground.

9. ENVIRONMENTAL CONDITIONS:

Operating Temperature: 0 to 40°C

Storage Temperature: -20 to 80°C

Operating and Storage Humidity: 80% max. relative humidity
(non-condensing) from 0°C to 40°C.

Altitude: Up to 2000 meters

10. **WEIGHT:** 2.3 lbs. (0.1 Kg)

INPUT/OUTPUT COMMUNICATIONS SPECS

1. **SERIAL PORTS:** Data Format and Baud Rates for each port is individually
software programmable up to 19200 baud.

Port 1: Programming Port - RS-232 on an RJ-11 jack.

Port 2: RS-232 Port on a Plug-In Screw Terminal Block

Port 3: RS-485 Port on a Plug-In Screw Terminal Block

(Up to 29 units can be connected and individually addressed. Can be used
as a three port device for multiple protocol applications.)

2. **COMMUNICATION MODES:** Any of the three ports can be used to
communicate with Serial Devices.

Model - (CX100) may communicate in Master mode with a different device
protocol on each port. (See Note & Exception).

However, only one of Ports 2 and 3 may be configured, if either is selected as
a Slave protocol.

*Note: Ports 2 and 3 may be configured as different device protocols in Master
mode and Port 1 may be used simultaneously in Slave mode for a third
device protocol.*

*Exception: If Allen Bradley DH485 is selected on either Port 2 or 3, only Port
1 will be available for a separate Device Protocol.*

COMMON FEATURES FOR CHARACTER BASED OPERATOR TERMINALS

PROGRAMMABILITY

Event Driven Configuration Tool

Edict 97, an extremely powerful Windows 95/3.11 based software program,
provides for the intuitive configuration of every aspect of the operator
interface's behavior. The requirement for time consuming PLC ladder logic is
drastically reduced by the unique event driven approach of EDICT 97. The
capability of this program, in conjunction with the PLC and the Paradigm
operator interface unit, ensures a great deal of advanced functionality for your
system. This powerful PLC/Paradigm system provides many of the capabilities
and features normally associated with the more complicated and costly
PC/SCADA systems. Display pages are easily generated, including PLC and
internal variables, text strings, or bar charts. All dynamic elements are also
available as alarms, recipes, triggers, and reports, for the run time software.
After completion of the programming, the program is directly downloaded to the
operator interface from your PC, without any compiling or saving requirement.
When you require a change in your program, EDICT 97 loads only the change,
not the entire program, saving valuable on-line time.

DYNAMIC DISPLAY PAGE ELEMENTS

Each display page has provisions to show static and dynamic information,
including data variables, text messages, time, and date.

Data Variables can be either PLC derived or internally generated, either in data
entry or display only mode. The Paradigm unit has an extremely powerful
math capability, allowing the operator to manipulate the variables to meet the
specific application's demands. If required, the display can be formatted to
BCD, binary, hex, floating point, and string. Upper and lower limits of data
entry variables are fully supported and able to be password protected.

Text Message Animation enables several different types of animated text from
a local or global message table to be displayed. The message displayed is
dependent on the condition of the particular controlling expression. The
controlling expression may be a PLC bit level, a timer value, preset counter
condition, or any one of a wide variety of message triggers.

Time and Date in the Paradigm unit has the capability to display in any
combination of year, month, day, hours, minutes, and seconds.

Bar Graphs in horizontal format are easily attached to data variables. The
partial or full length bar graph displays can be scaled and offset to optimize
the required display effect.

SECURITY

The password protection scheme provides the ultimate in tamper-proof
capability. Access can be limited on a unit, page, recipe, or even individual
data entries.

ALARMS

The Paradigm unit can monitor and log from 100 to 500 alarms, depending
on model. Such triggers as a simple bit level transition, a PLC coil activation, or
a complex application algorithm can activate an alarm. The alarms can be time
and date stamped, with an automatic screen display and/or downloading to a
printer for hard copy recording purposes.

REAL TIME SCHEDULE

Real time schedule allows for repetitive or one time task to take place in the
system. Typically a schedule action similar to...At 1:55 PM on Monday,
Wednesday, and Friday, print the production report...is required in the
application. In conjunction with the recipe capabilities, a downloading of a
special recipe can be requested by the real time schedule feature.

USER PROGRAMS

This feature offers the user the ability to incorporate custom application
requirements via a powerful program language. For example, a program
designated "Calculate Volume" which determines the amount of fluid in a round
tank at specific temperatures could be created. This program would be triggered
to run and display each time the page denoted as "Volume Now" is requested.

The ability to customize to your application's specialized needs is easily
solved with the user program capability.

KEYBOARD EDITING

All the interface keys can be programmed to perform virtually unlimited
functions with each key, having multiple actions assigned to three types of key
events: key pressed, key held down (auto repeat), and key released. Typical key
actions would be Go to page, set value, load recipe, view alarms, print report,
and many more.

COMMUNICATIONS

With over 70 communication drivers available, the Paradigm operator
interface offers a wide range of connectivity including: PLCs, Variable Speed
Drives, Temperature Controllers, Bar Code Readers, etc. Utilizing real PLC data
references, the automatic comms configuration optimizes the system's
communication performance. In the event that your specific driver does not
appear on the Paradigm drivers list, let us know, as this list is always being
expanded to meet our customers' needs.

HARDWARE INFORMATION

This bulletin contains a variety of information related to the installation and operation of the Operator Interface supplied. Ideally, you should read this document thoroughly before attempting to use the equipment. For information about the software aspects of the terminal, please consult other documentation.

CONTENTS OF PACKAGE

The Operator Interface is supplied in a packaging box containing the following...

- ◆ The interface terminal itself.
- ◆ A NEMA 4/IP65 rated mounting gasket.
- ◆ A bag containing panel hardware.
- ◆ This hardware bulletin.
- ◆ If any of these items are missing, please contact your supplier immediately.



ALL NONINCENDIVE CIRCUITS MUST BE WIRED USING DIVISION 2 WIRING METHODS AS SPECIFIED IN ARTICLE 501-4 (b), 502-4 (b), AND 503-3 (b) OF THE NATIONAL ELECTRICAL CODE, NFPA 70 FOR INSTALLATION WITHIN THE UNITED STATES, OR AS SPECIFIED IN SECTION 19-152 OF CANADIAN ELECTRICAL CODE FOR INSTALLATION IN CANADA.

POWER SUPPLY REQUIREMENTS

The Operator Interface requires an 11 to 30 VDC power supply rated at 2.5 W unless otherwise stated on the label.

- ◆ The terminal may take as little as 100 mA in certain circumstances, so be sure that the chosen power supply can operate correctly with this load. Large switch-mode supplies tend to need a certain minimum load before they will operate correctly.

In any case, it is very important that the power supply is mounted correctly if the unit is to operate reliably. A very high proportion of reported problems are caused by incorrect power supply installation, so please take care to observe the following points...

- ◆ The power supply must be mounted close to the unit, with usually not more than 6 feet of cable between the supply and the Operator Interface. Ideally, as short a length as is possible should be used.
- ◆ The wire used to connect the Operator Interface's power supply should be of at least 22 gage wire. If a longer cable run is used, you should use heavier gage wire. The routing of the cable should be kept away from large contactors, inverters and other devices which may generate significant electrical noise.

BATTERY BACKUP ISSUES

The Operator Interface is supplied with a Lithium Battery designed to maintain the internal memory and real-time clock during power outages. Assuming the operator interface terminal is powered up for 50% of the time, this battery should last over 4 years. A "Battery Low" system variable is available so that the programmer can choose specific action(s) to occur when the battery voltage drops below its nominal voltage.

It is possible to replace the battery without losing the contents of the Operator Interface's memory, but this does not reduce the importance of ensuring that a copy of the terminal's configuration is kept readily at hand to allow the terminal to be re-loaded in the case of mishaps. Please remember that although an image of the database contents can be uploaded, this file is not editable, so the importance of keeping a copy on disk cannot be overstressed.



WARNING - EXPLOSION HAZARD - THE AREA MUST BE KNOWN TO BE NON-HAZARDOUS BEFORE SERVICING/ REPLACING THE UNIT AND BEFORE INSTALLING OR REMOVING I/O WIRING AND BATTERY.



WARNING - EXPLOSION HAZARD - DO NOT DISCONNECT EQUIPMENT UNLESS POWER HAS BEEN DISCONNECTED AND THE AREA IS KNOWN TO BE NON-HAZARDOUS.

CHANGING THE BATTERY

To change the internal battery, follow these steps...

- ◆ Remove the power and PLC communications connector from the unit.
- ◆ Remove the four screws from the rear-cover and remove the rear cover.
- ◆ If you wish to avoid losing the terminal's configuration, reconnect the power connector and re-apply power. Note that this will require the panel to be powered-up and, as such, only suitably qualified staff should carry out this procedure.

- ◆ The battery is located in a holder on the main circuit board. This should be clearly visible. Remove the battery from its holder.
- ◆ Place the new battery in the holder. The terminal's power supply can now be disconnected, if you re-applied power in the step above.
- ◆ Replace the lid, screws and connector by following the above procedure in reverse. You may like to make a note of the date the battery was replaced to allow planned maintenance to be carried out.
- ◆ If you did not keep the unit powered-up during battery replacement, hold down the EXIT and MUTE keys on the keyboard and cycle power. Release the keys and follow the menu guides to clear the memory. The unit is now ready for a configuration database to be reloaded.

Please note that the old battery must be disposed of in a manner which complies with your local waste regulations. Also, the battery must not be disposed of in fire or in a manner whereby it may be damaged and its contents come into contact with human skin.

INSTALLATION & CONNECTIONS

The unit meets NEMA 4/IP65 requirements for indoor use, when properly installed. The units are intended to be mounted into an enclosed panel.

Installation Environment

The unit should be installed in a location that does not exceed the maximum operating temperature and provides good air circulation. Placing the unit near devices that generate excessive heat should be avoided.

Continuous exposure to direct sunlight may accelerate the aging process of the bezel. The bezel should be cleaned only with a soft cloth and neutral soap product. Do NOT use solvents.

Do not use tools of any kind (screwdrivers, pens, pencils, etc.) to operate the keypad of the unit.

CONNECTING TO A PLC

The Operator Interface is designed to operate with a PLC. A serial communication connection must be made between the operator interface terminal and PLC, and the details of this connection vary according to which PLC is used.

The following section lists the connection details for the PLC to be used .

PLC TYPE

Details on how to connect to most PLCs are available on request from RLC.

CONNECTING TO AN IBM® PC/AT

The Operator Interface is programmed via software running on an IBM PC/AT or a compatible computer. The connection between the PC/AT and the operator interface terminal is made via a custom cable provided with the EDICT Developer's Kit. The cable is designed for a 9-way serial port. Please contact your supplier if you require a 25-way version.

PROGRAMMING PORT PIN OUT

The Operator Interface's programming port is sometimes used to connect other RS-232 devices, such as printers. The following illustration and table gives the pin-out of this port to enable such connections to be made.

RJ11 FEMALE	
PIN	NAME
1	RTS
2	Tx
3	GND
4	GND
5	Rx
6	CTS

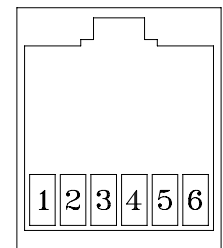

Rear View of Unit

The above table denotes the pin names of the programming port. When connecting, the pin name at the programming port is connected to the opposite of that pin name at the destination device.

MOUNTING INSTRUCTIONS

The Operator Interfaces are designed for through-panel mounting. A neoprene gasket is provided, to enable sealing to NEMA 4/IP65 specification. The panel cut-out diagram for the model supplied is provided. All mounting holes should be drilled for 0.14" (3.5 mm) clearance. Care should be taken to remove any loose material from the mounting hole to avoid such metal falling into the Operator Interface itself during installation.

FUNCTION KEY STRIPS

The function keys on the CX200 have clear windows that permit the user to insert labels appropriate to the process. A formatted page is supplied upon which the user can enter function names (e.g. RUN, PRINT, etc.). These strips are inserted from the rear of the panel through slots below the function keys located underneath the gasket.

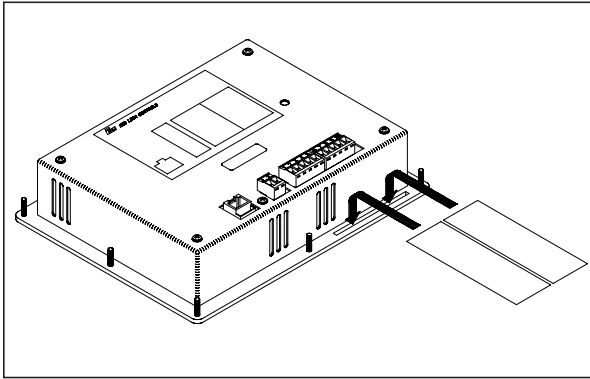

Take care that the ink applied will not rub off of the paper, or else blemishes will be left on the inside of the window. Laminated paper or plastic film can prove easier to insert than normal photocopier paper. It also helps if the starting edge of the paper has about 0.25 inches of its corners cut off at a 45 degree angle.

Note: Add an additional 1.5" to label length to allow for easier insertion and removal.

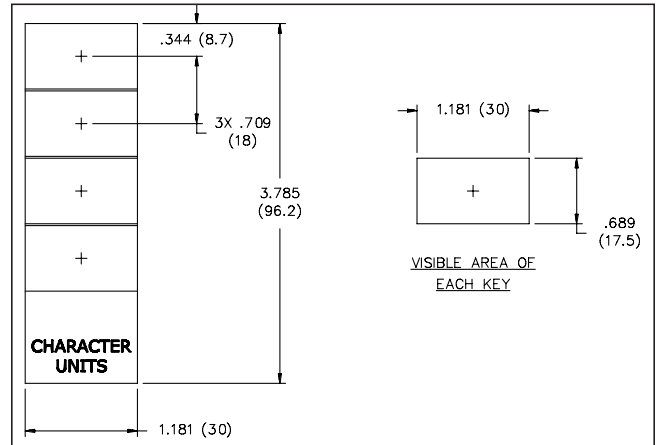

TROUBLESHOOTING

For further technical assistance, contact technical support at the appropriate company numbers listed.

© 2003, RED LION CONTROLS, ALL RIGHTS RESERVED.

Information in this document is subject to change without notice and does not represent a commitment by Red Lion Controls. Software, which includes any database supplied therewith, described in this document may be furnished subject to a license agreement or a nondisclosure agreement. It is against the Law to copy the software except as specifically allowed in the license or nondisclosure agreement. No part of this document may be reproduced in any form or by any means, electronic or mechanical, including photocopying and recording, for any purpose, without the express written permission of Red Lion Controls.

PowerPoint and Windows are registered trademarks of Microsoft Corporation. Other product and company names mentioned herein may be the trademarks of their respective owners.

Disclaimer

Red Lion Controls, hereinafter referred to as RLC, will under no circumstances be responsible for direct, indirect, special, incidental or consequential damages, death or personal injury arising from the use or misuse of all or part of this documentation or the products and software described herein. Notwithstanding the above, RLC does not exclude any liability for death or personal injury caused by its negligence.

RLC does not warrant any of its software products to be free from error or to be fit for any particular purpose. Neither is the software guaranteed to provide operation without interruption. The customer's sole remedy in case of failure is the refund of the purchase price of the software.

The customer, in applying the products and software described herein, accepts that the products are wholly or partly programmable electronic systems that are inherently complex and which cannot thus be guaranteed to be free of errors. In doing so, the customer accepts the responsibility to ensure that the products are correctly programmed, configured, installed, commissioned, operated and maintained by competent and suitably trained staff and according to any instructions or safety instructions provided and as dictated by good engineering practices.

This documentation, and the software and products described herein, is subject to continuous development and improvement. All information is given in good faith, but RLC shall not be liable for any omissions or errors herein or within the software herein described.