

MODEL CUB7W3 - MINIATURE ELECTRONIC 8 DIGIT COUNTER

- LCD, REFLECTIVE OR TRANSMISSIVE WITH YELLOW/GREEN OR RED LED BACKLIGHTING (9-28 VDC power supply required for versions with LED backlighting)
- 0.35" (8.90 mm) HIGH DIGITS
- REPLACEABLE INTERNAL LITHIUM BATTERY PROVIDES UP TO 7 YEARS OF UNINTERRUPTED OPERATION
- NEMA 4X/IP65 SEALED FRONT BEZEL
- COUNT INPUT FROM 10 to 30 VAC/DC
- WIRE CONNECTION MADE VIA SCREW CLAMP TYPE TERMINALS
- FITS DIN STANDARD CUT-OUT 1.77" (45 mm) x 0.874" (22.2 mm)

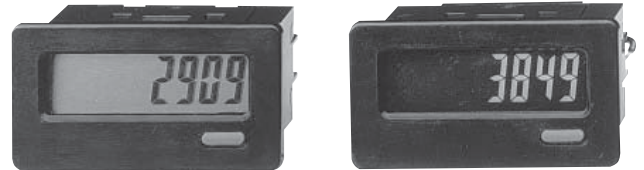

DESCRIPTION

The CUB7 series is an 8-digit miniature counter with large 0.35 inch (8.90 mm) high digits. It has an LCD read-out available in Positive Image Reflective, Negative Image Transmissive with yellow/green backlighting or red backlighting. The backlight versions require an external 9 to 28 VDC power supply.

The CUB7 series use a CMOS LSI counter circuit chip, mounted on a gold-plated substrate, that is electrically connected by ultrasonic wire-bonding. Proven micro-electronic assembly and manufacturing techniques provide these units with the reliability and dependability required for industrial service.

The CUB7 series is housed in a lightweight, high impact plastic case with a clear viewing window. The sealed front panel with the silicone rubber reset button meets NEMA 4X/IP65 specifications for wash-down and/or dusty environments, when properly installed.

SAFETY SUMMARY

All safety related regulations, local codes and instructions that appear in the manual or on equipment must be observed to ensure personal safety and to prevent damage to either the instrument or equipment connected to it. If equipment is used in a manner not specified by the manufacturer, the protection provided by the equipment may be impaired.

Do not use this unit to directly command motors, valves, or other actuators not equipped with safeguards. To do so, can be potentially harmful to persons or equipment in the event of a fault to the unit.

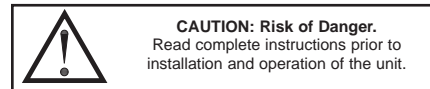

ORDERING INFORMATION

MODEL NO.	DESCRIPTION	PART NUMBERS
CUB7W3 *	Counter Positive Image Reflective	CUB7W300
	Counter w/Yel-Grn Backlighting	CUB7W310
	Counter w/Red Backlighting	CUB7W320
BNL	3 V Lithium Battery	BNL10000

For more information on Pricing, Enclosures & Panel Mount Kits refer to the RLC Catalog or contact your local RLC distributor.

*Battery is included with unit.

SPECIFICATIONS

- DISPLAY:** 8-digit LCD, 0.35" (8.90 mm) high digits.
- POWER SOURCE:** Replaceable Internal 3.0 V lithium battery to provide up to 7 years of continuous operation. (Battery life is dependent upon usage. Count and reset contacts that remain closed for long periods of time reduce battery life.)
- BACKLIGHT POWER REQUIREMENTS:** 9 to 28 VDC; 35 mA. typical, 50 mA max. Above 26 VDC, derate max. operating temperature to 40°C. Must use a NEC Class 2 or SELV rated power supply.
- INPUTS:** V_{IL} (low) = 0.5 V max
 Low speed input: 10 to 30 VAC/DC, 50/60 Hz, 30 cps max. Unit counts on positive going edge.
- REMOTE RESET:** 15 msec min. pulse width (active low) from 3.0 V bipolar output, an open collector transistor, or a switch contact to common.

DIMENSIONS In inches (mm)

Note: Recommended minimum clearance (behind the panel) for mounting clip installation is 2.15" (54.6) H x 3.00" (76.2) W.

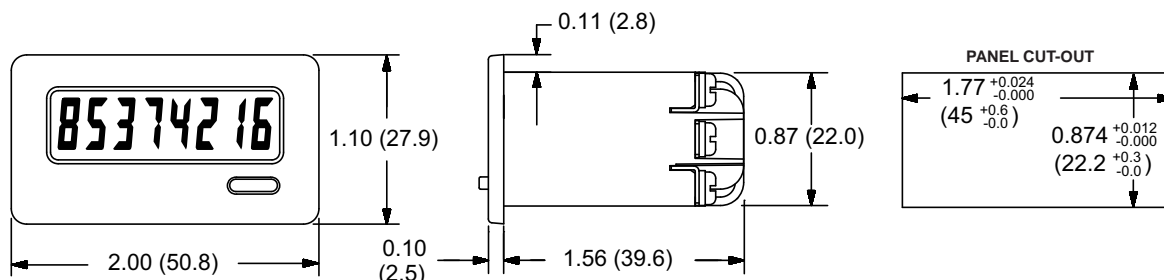

6. CERTIFICATIONS AND COMPLIANCES:

SAFETY

IEC 61010-1, EN 61010-1: Safety requirements for electrical equipment for measurement, control, and laboratory use, Part 1.

IP65 Enclosure rating (Face only), IEC 529

Type 4X Indoor Enclosure rating (Face only)

ELECTROMAGNETIC COMPATIBILITY

Immunity to EN 50082-2

Electrostatic discharge	EN 61000-4-2	Level 2; 4 Kv contact Level 3; 8 Kv air
Electromagnetic RF fields	EN 61000-4-3	Level 3; 10 V/m 80 MHz - 1 GHz
Fast transients (burst)	EN 61000-4-4	Level 4; 2 Kv I/O ¹ Level 3; 2 Kv power
RF conducted interference	EN 61000-4-6	Level 3; 10 V/rms ² 150 KHz - 80 MHz
Power frequency magnetic fields	EN 61000-4-8	Level 4; 30 A/m
Simulation of cordless telephone	ENV 50204	Level 3; 10 V/m 900 MHz ± 5 MHz 200 Hz, 50% duty cycle

Emissions to EN 50081-1

RF interference	EN 55022	Enclosure class B Power mains class B
-----------------	----------	--

Notes:

1. Burst to DC backlight power had a power line filter installed RLC #LFIL0000 or equivalent at the unit.

2. Self-recoverable loss of performance during EMI disturbance at 10 V/ rms to backlight power lines.

LCD segments may flicker during EMI disturbance.

For operation without loss of performance:

Install power line filter RLC #LFIL0000 or equivalent at the unit.

Refer to the EMC Installation Guidelines section of this bulletin for additional information.

7. ENVIRONMENTAL CONDITIONS:

Operating Temperature Range: 0 to 50°C Derate max. operating temperature to 40°C above 26 VDC. (Backlight versions)

Storage Temperature Range: -30 to 80°C

Operating and Storage Humidity: 85% max. (non-condensing) from 0°C to 50°C.

Vibration According to IEC 68-2-6: Operational 5 to 500 Hz, in X, Y, Z direction for 1.5 hours, 5 g's.

Shock According to IEC 68-2-27: Operational 30 g's, 11 msec in 3 directions. **Altitude:** Up to 2000 meters

8. **CONSTRUCTION:** High impact plastic case with clear viewing window. The front panel meets NEMA 4X/IP65 requirements for indoor use when properly installed. Installation Category I, Pollution Degree 2. Panel gasket and mounting clip included.

9. **CONNECTIONS:** Wire clamping screw terminals

Wire Strip Length: 0.3" (7.5 mm).

Wire Gauge: 30-14 AWG copper wire

Torque: 5 inch-pounds (0.565 N-m) max.

10. **WEIGHT:** 2 oz. (57 grams) [with battery]

EMC INSTALLATION GUIDELINES

Although this unit is designed with a high degree of immunity to ElectroMagnetic Interference (EMI), proper installation and wiring methods must be followed to ensure compatibility in each application. The type of the electrical noise, source or coupling method into the unit may be different for various installations. In extremely high EMI environments, additional measures may be needed. The unit becomes more immune to EMI with fewer I/O connections. Cable length, routing and shield termination are very important and can mean the difference between a successful installation or a troublesome installation. Listed below are some EMC guidelines for successful installation in an industrial environment.

- Use shielded (screened) cables for all Signal and Control inputs. The shield (screen) pigtail connection should be made as short as possible. The connection point for the shield depends somewhat upon the application. Listed below are the recommended methods of connecting the shield, in order of their effectiveness.
 - Connect the shield only at the panel where the unit is mounted to earth ground (protective earth).
 - Connect the shield to earth ground at both ends of the cable, usually when the noise source frequency is above 1 MHz.
 - Connect the shield to common of the unit and leave the other end of the shield unconnected and insulated from earth ground.
- Never run Signal or Control cables in the same conduit or raceway with AC power lines, conductors feeding motors, solenoids, SCR controls, and heaters, etc. The cables should be run in metal conduit that is properly

grounded. This is especially useful in applications where cable runs are long and portable two-way radios are used in close proximity or if the installation is near a commercial radio transmitter.

- Signal or Control cables within an enclosure should be routed as far away as possible from contactors, control relays, transformers, and other noisy components.
- In extremely high EMI environments, the use of external EMI suppression devices, such as ferrite suppression cores, is effective. Install them on Signal and Control cables as close to the unit as possible. Loop the cable through the core several times or use multiple cores on each cable for additional protection. Install line filters on the power input cable to the unit to suppress power line interference. Install them near the power entry point of the enclosure. The following EMI suppression devices (or equivalent) are recommended:

Ferrite Suppression Cores for signal and control cables:

Fair-Rite # 0443167251 (RLC #FCOR0000)

TDK # ZCAT3035-1330A

Steward #28B2029-0A0

Line Filters for input power cables:

Schaffner # FN610-1/07 (RLC #LFIL0000)

Schaffner # FN670-1.8/07

Corcom #1VR3

Note: Reference manufacturer's instructions when installing a line filter.

- Long cable runs are more susceptible to EMI pickup than short cable runs. Therefore, keep cable runs as short as possible

WIRING CONNECTIONS

The electrical connections are made via screw-clamp terminals located on the back of the unit. All conductors should meet voltage and current ratings for each terminal. Also cabling should conform to appropriate standards of good installation, local codes and regulations. It is recommended that power supplied to the unit (AC or DC) be protected by a fuse or circuit breaker. When wiring the unit, use the battery cover to identify the wire position with the proper function. Strip the wire, leaving approximately 1/4" bare wire exposed (stranded wires should be tinned with solder). Insert the wire under the screw-clamp and tighten down the screw until the wire is clamped in tightly. Each terminal can accept up to two #14 AWG wires.

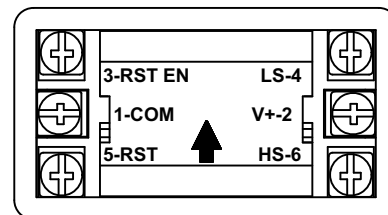

WARNING: Lithium battery may explode if incinerated. All leads will be at the same line potential as the input leads.

L. S. INPUT, 30 CPS MAX.

The CUB7W3 accepts most machine control voltage signals. The input accepts AC (50/60 Hz) or DC control voltages from 10 to 30 V at count speeds up to 30 cps. The unit counts on the positive going edge of the input signal.

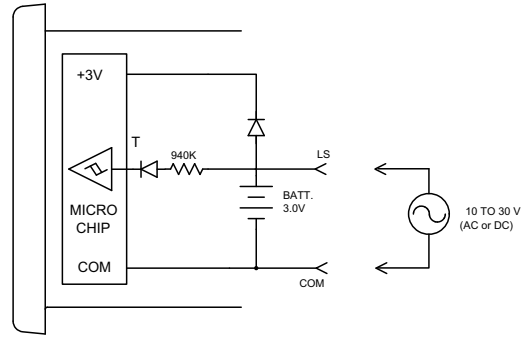

INSTALLATION ENVIRONMENT

The unit should be installed in a location that does not exceed the maximum operating temperature and provides good air circulation. Placing the unit near devices that generate excessive heat should be avoided.

The bezel should be cleaned only with a soft cloth and neutral soap product. Do NOT use solvents.

Continuous exposure to direct sunlight may accelerate the aging process of the bezel.

Do not use tools of any kind (screwdrivers, pens, pencils, etc.) to operate the keypad of the unit.

Installation

The CUB7 series of products meets NEMA 4X/IP65 requirements for indoor use, when properly installed. The units are intended to be mounted into an enclosed panel. The viewing window and reset button are factory sealed for a washdown environment. A sponge rubber gasket and mounting clip are provided for installing the unit in the panel cut-out.

The following procedure assures proper installation:

1. Cut panel opening to specified dimensions. Remove burrs and clean around panel opening.
2. Carefully remove and discard the center section of the gasket. Slide the panel gasket over the rear of the unit to the back of the bezel. Insert the mounting screws onto both sides of mounting clip. Tip of screw should **NOT** project from hole in mounting clip.
3. Install CUB7 unit through the panel cut-out until front bezel flange contacts the panel.
4. Slide the mounting clip over the rear of the unit until the clip is against the back of the panel. The mounting clip has latching features which engage into mating features on the CUB7 housing.

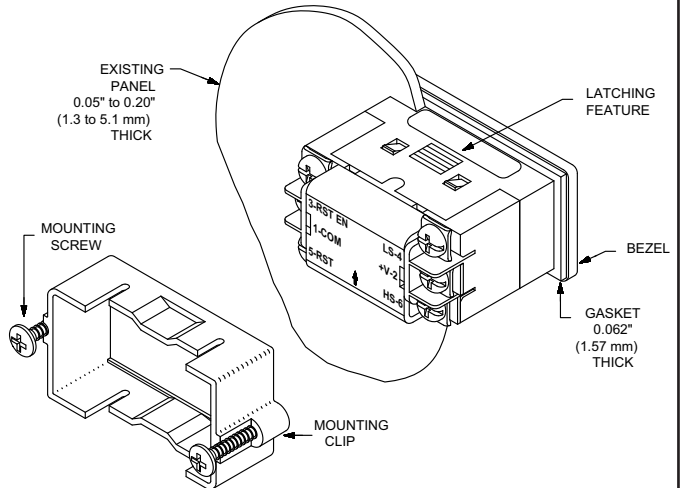

Note: It is necessary to hold the unit in place when sliding mounting clip into position.

5. Alternately tighten each screw to ensure uniform gasket pressure. Visually inspect the front panel gasket. The gasket should be compressed to about 75 to 80% of its original thickness. If not, gradually turn mounting screws to further compress gasket.
6. If gasket is not adequately compressed and the mounting screws can no longer be turned, loosen mounting screws, and check that mounting clip is latched as close as possible to the panel.
7. Repeat from step #5 for tightening mounting screws.

BATTERY INSTALLATION

1. Remove all power to the unit before removing battery cover.
2. To remove battery cover, push upward in the direction of the arrow on rear cover (See drawing at right), until the cover unlatches. Pull cover straight out from unit to fully remove.
3. Remove old battery* and replace with an RLC battery (BNL10000). Observe proper polarity when replacing battery as shown in drawing.
4. Replace cover. The battery cover is keyed so that it cannot be placed upside down. The arrow on the rear of the cover should point toward the top of the CUB7 series when properly installed

* - Dispose of properly.



WARNING: Lithium battery may explode if incinerated.

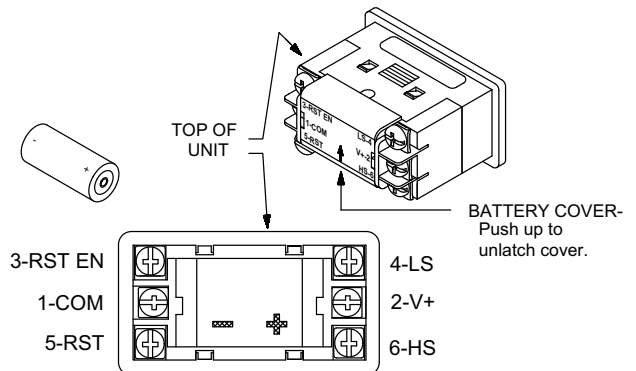

RESET OPTIONS (CUB7 SERIES)

Connecting a wire from the RST. EN. (Reset Enable) Input terminal to Common will enable the front panel Reset button.

Pulling the "RST." input low causes the counter to reset. The "RST." can be pulled low by either a mechanical switch or solid-state transistor switch. Switch load is 15 μ A (max. voltage drop 0.5 V) when on. The off-state leakage current must be less than 2 μ A

Note: The RC protection circuit on the "RST." Input causes a delay of approximately 15 msec in Reset response.

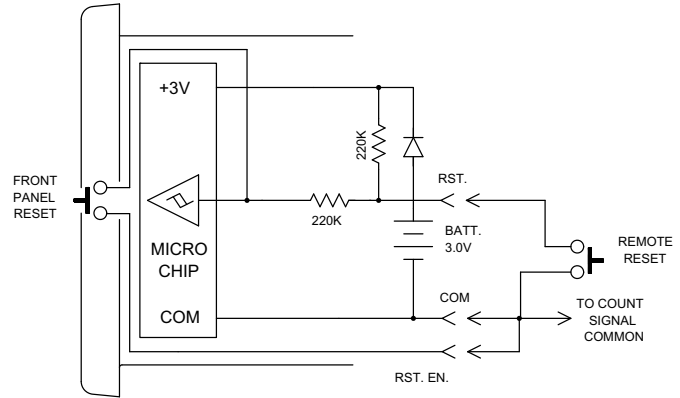

BACKLIGHT OPTION (CUB7 SERIES)

Optional backlight versions of the CUB7 series require an external 9-28 VDC power supply. The external supply is connected between V+ and Common terminals as shown by the solid line in the drawing.

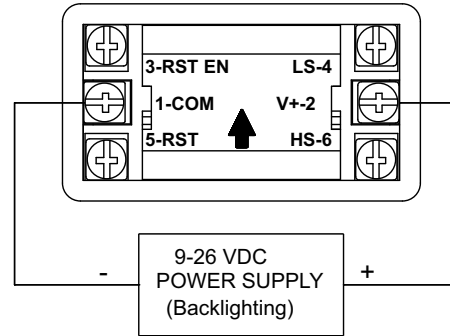

TROUBLESHOOTING

For further technical assistance, contact technical support at the appropriate company numbers listed.

LIMITED WARRANTY

The Company warrants the products it manufactures against defects in materials and workmanship for a period limited to two years from the date of shipment, provided the products have been stored, handled, installed, and used under proper conditions. The Company's liability under this limited warranty shall extend only to the repair or replacement of a defective product, at The Company's option. The Company disclaims all liability for any affirmation, promise or representation with respect to the products.

The customer agrees to hold Red Lion Controls harmless from, defend, and indemnify RLC against damages, claims, and expenses arising out of subsequent sales of RLC products or products containing components manufactured by RLC and based upon personal injuries, deaths, property damage, lost profits, and other matters which Buyer, its employees, or sub-contractors are or may be to any extent liable, including without limitation penalties imposed by the Consumer Product Safety Act (P.L. 92-573) and liability imposed upon any person pursuant to the Magnuson-Moss Warranty Act (P.L. 93-637), as now in effect or as amended hereafter.

No warranties expressed or implied are created with respect to The Company's products except those expressly contained herein. The Customer acknowledges the disclaimers and limitations contained herein and relies on no other warranties or affirmations.

Red Lion Controls
Headquarters
20 Willow Springs Circle
York PA 17406
Tel +1 (717) 767-6511
Fax +1 (717) 764-0839

Red Lion Controls
Europe
Printerweg 10
NL - 3821 AD Amersfoort
Tel +31 (0) 334 723 225
Fax +31 (0) 334 893 793

Red Lion Controls
India
54, Vishvas Tenement
GST Road, New Ranip,
Ahmedabad-382480 Gujarat, India
Tel +91 987 954 0503
Fax +91 79 275 31 350

Red Lion Controls
China
Unit 101, XinAn Plaza
Building 13, No.99 Tianzhou Road
ShangHai, P.R. China 200223
Tel +86 21 6113-3688
Fax +86 21 6113-3683