

MODEL CL01 - SUPPORTING BANNER PRESENCE PLUS VISION SYSTEMS - PARADIGM 2 X 20 LCD OPERATOR INTERFACE TERMINAL



The diskette included with this shipment includes the Banner PresencePLUS load utility, EDICT driver, and application note. Please read and follow the instructions in the application note for loading and using the Banner PresencePLUS load utility and EDICT driver.

DESCRIPTION

The Paradigm operator interface Model CL01 was designed to meet the industrial demands of application power, versatility, reliability, and ease of use. The CL01 has provisions, common to all Paradigm Family products, allowing for future product upgrades as new options and capabilities are developed.

SAFETY SUMMARY

All safety related regulations, local codes and instructions that appear in the manual or on equipment must be observed to ensure personal safety and to prevent damage to either the instrument or equipment connected to it. If equipment is used in a manner not specified by the manufacturer, the protection provided by the equipment may be impaired.

Do not use this unit to directly command motors, valves, or other actuators not equipped with safeguards. To do so, can be potentially harmful to persons or equipment in the event of a fault to the unit.

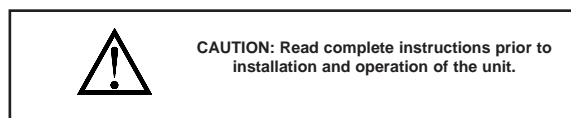

- 2 LINE X 20 CHARACTER LIQUID CRYSTAL DISPLAY WITH LED BACKLIGHT
- 100 ALARM POINT LOGGER
- RECIPE HANDLING
- UNLIMITED PASSWORD PROTECTION
- REAL TIME CLOCK, BATTERY BACKED
- EXPRESSION EVALUATION
- 32-BIT MATH
- DIRECT PLC COMMUNICATION
- NEMA 4/IP65



UL **Recognized Component,**
 File # E179259

SPECIFICATIONS

1. **POWER REQUIREMENTS:** 11 to 30 VDC @ 2.5 W
Power Up Current: 2.5 A for 1 msec max.
 Must use a Class 2 or SELV rated power supply.
2. **DISPLAY:** 2 lines of 20 characters, 0.197" (5 mm) high liquid crystal display with bright LED backlight.
3. **KEYPAD:** 3 screen legendable soft keys, numeric pad with raise, lower, next, previous, enter, delete, exit, alarms and mute keys.
4. **MEMORY:** 128 K (64 K user) battery backed RAM (Battery life expectancy 7 years 50/50 on/off cycle) Optional factory fit expansion to 512 K (448 K user).
5. **PHYSICAL DIMENSIONS:** L = 6.69" (170 mm), H = 5.12" (130 mm), D = 2.2" (56 mm.)

ORDERING INFORMATION

MODEL NO.	DESCRIPTION	PART NUMBER
CL01	LCD, 2 X 20, 3 Soft keys, 128 K memory, supporting Banner PresencePlus vision systems	CL010050
	LCD, 2 X 20, 3 Soft keys, 512 K memory, supporting Banner PresencePlus vision systems	CL010060
	EDICT-97 Development Kit. Includes Software, Manual and 9-pin RS232 Programming cables	SFEDT
	Banner PresencePlus Communications Cable	P895064Z
	Port 1 adapter cable	P890807Z
	Port 1 adapter cable, din rail mountable	P890808Z
	Communication Cables	P895xxxZ
	Battery Replacement	BAL3R004

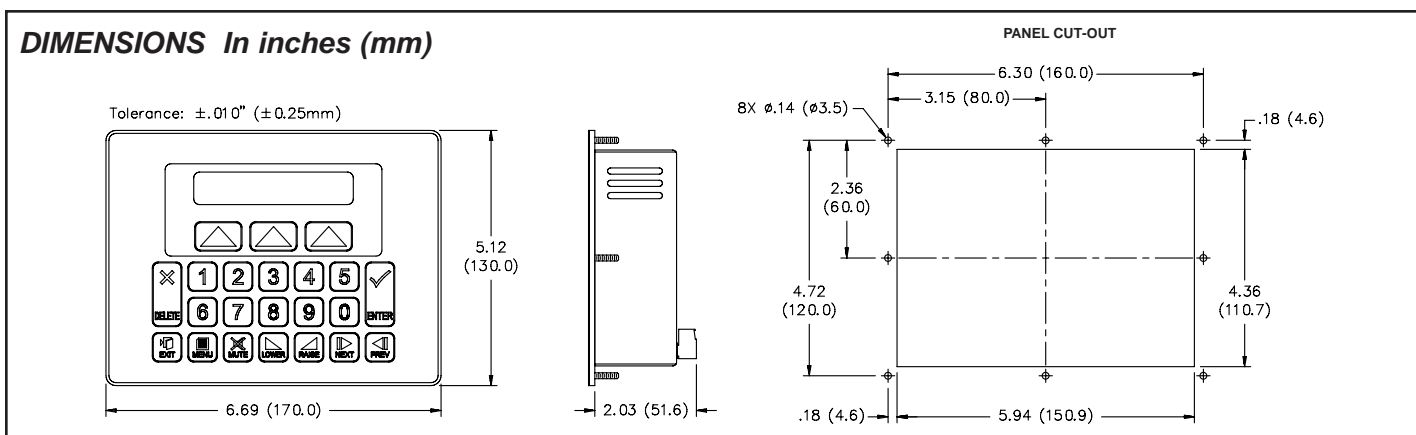

6. **CONSTRUCTION:** Steel rear metal enclosure with NEMA 4/IP65 aluminum front plate when correctly fitted with the gasket provided. This unit is rated for NEMA 4/IP65 indoor use. Installation Category I, Pollution Degree 2.
7. **MOUNTING REQUIREMENTS:** Max. panel thickness is 0.375" (9.5 mm). For NEMA 4/IP65 sealing, a steel panel with a minimum thickness of 0.125" (3.175 mm) is recommended.
8. **ENVIRONMENTAL CONDITIONS:**
Operating Temperature: 0 to 40°C
Storage Temperature: -20 to 80°C
Operating and Storage Humidity: 80% max. relative humidity (non-condensing) from 0°C to 40°C.
Altitude: Up to 2000 meters
9. **CERTIFICATIONS AND COMPLIANCES:**
SAFETY
 UL Recognized Component, File #E179259, UL3101-1, CSA 22.2 No.1010-1 Recognized to U.S. and Canadian requirements under the Component Recognition Program of Underwriters Laboratories, Inc
 Type 4 Enclosure rating (Face only), UL50
 IECCE CB Scheme Test Certificate #UL2795A-179259/USA
 CB Scheme Test Report #98ME60993-000098
 Issued by Underwriters Laboratories Inc.
 IEC 1010-1, EN 61010-1: Safety requirements for electrical equipment for measurement, control, and Laboratory use, Part 1
 IP65 Enclosure rating (face only), IEC 529

ELECTROMAGNETIC COMPATIBILITY

- EN 50081-2 : 1994 Electromagnetic Compatibility Directive
 Generic Emission Standard
 Part 2 : Industrial Environment
- EN 50082-2 : 1994 Electromagnetic Compatibility Directive
 Generic Immunity Standard
 Part 2 : Industrial Environment
- EN 55022-B : 1995 Limits and Methods of Measurement of Radio
 Disturbance Characteristics of Information
 Technology Equipment

10. **WEIGHT:** 1.6 lbs. (0.72 Kg)

INPUT/OUTPUT COMMUNICATIONS SPECS

1. **SERIAL PORTS:** Data Format and Baud Rates for each port is individually software programmable up to 19200 baud, except for the Banner PP, which will communicate at 115 kBaud.
 Port 1: Programming Port - RS-232 on an RJ-11 jack.
 Port 2: RS-232 Port on a Plug-In Screw Terminal Block
 Port 3: RS-485 Port on a Plug-In Screw Terminal Block
 (Up to 29 Units can be connected and individually addressed.)
Note: LED Indicators show communications status on Ports 2 & 3
2. **COMMUNICATION MODES:** Any of the three ports can be used to communicate with Serial Devices.
 Model - (CL01) only one of Ports 1, 2, and 3 may be configured.
Exception Red Lion Controls Instrument, simple ASCII Printer, PC Link Network, Program Through, External Keyboards, Banner Presence Plus Visions Systems and Roll-Your-Own Protocols can be used with other protocols on Port 1.

COMMON FEATURES FOR CHARACTER BASED OPERATOR TERMINALS

PROGRAMMABILITY

Event Driven Configuration Tool

Edict 97, an extremely powerful Windows 98/95/3.11 based software program, provides for the intuitive configuration of every aspect of the operator interface's behavior. The requirement for time consuming PLC ladder logic is drastically reduced by the unique event driven approach of EDICT 97. The capability of this program, in conjunction with the PLC and the Paradigm operator interface unit, ensures a great deal of advanced functionality for your system. This powerful PLC/Paradigm system provides many of the capabilities and features normally associated with the more complicated and costly PC/SCADA systems. Display pages are easily generated, including PLC and internal variables, text strings, or bar charts. All dynamic elements are also available as alarms, recipes, triggers, and reports, for the run time software. After completion of the programming, the program is directly downloaded to the operator interface from your PC, without any compiling or saving requirement. When you require a change in your program, EDICT 97 loads only the change, not the entire program, saving valuable on-line time.

DYNAMIC DISPLAY PAGE ELEMENTS

Each display page has provisions to show static and dynamic information, including data variables, text messages, time, and date.

Data Variables can be either PLC derived or internally generated, either in data entry or display only mode. The Paradigm unit has an extremely powerful math capability, allowing the operator to manipulate the variables to meet the specific application's demands. If required, the display can be formatted to BCD, binary, hex, floating point, and string. Upper and lower limits of data entry variables are fully supported and able to be password protected.

Text Message Animation enables several different types of animated text from a local or global message table to be displayed. The message displayed is dependent on the condition of the particular controlling expression. The controlling expression may be a PLC bit level, a timer value, preset counter condition, or any one of a wide variety of message triggers.

Time and Date in the Paradigm unit has the capability to display in any combination of year, month, day, hours, minutes, and seconds.

Bar Graphs in horizontal format are easily attached to data variables. The partial or full length bar graph displays can be scaled and offset to optimize the required display effect.

SECURITY

The password protection scheme provides the ultimate in tamper-proof capability. Access can be limited on a unit, page, recipe, or even individual data entries.

ALARMS

The Paradigm unit can monitor and log from 100 to 500 alarms, depending on model. Such triggers as a simple bit level transition, a PLC coil activation, or a complex application algorithm can activate an alarm. The alarms can be time and date stamped, with an automatic screen display and/or downloading to a printer for hard copy recording purposes.

REAL TIME SCHEDULE

Real time schedule allows for repetitive or one time task to take place in the system. Typically a schedule action similar to...At 1:55 PM on Monday, Wednesday, and Friday, print the production report...is required in the application. In conjunction with the recipe capabilities, a downloading of a special recipe can be requested by the real time schedule feature.

USER PROGRAMS

This feature offers the user the ability to incorporate custom application requirements via a powerful program language. For example, a program designated "Calculate Volume" which determines the amount of fluid in a round tank at specific temperatures could be created. This program would be triggered to run and display each time the page denoted as "Volume Now" is requested.

The ability to customize to your application's specialized needs is easily solved with the user program capability.

KEYBOARD EDITING

All the interface keys can be programmed to perform virtually unlimited functions with each key, having multiple actions assigned to three types of key events: key pressed, key held down (auto repeat), and key released. Typical key actions would be Go to page, set value, load recipe, view alarms, print report, and many more.

COMMUNICATIONS

With over 70 communication drivers available, the Paradigm operator interface offers a wide range of connectivity including: PLCs, Variable Speed Drives, Temperature Controllers, Bar Code Readers, etc.

Utilizing real PLC data references, the automatic comms configuration optimizes the system's communication performance. In the event that your specific driver does not appear on the Paradigm drivers list, let us know, as this list is always being expanded to meet our customers' needs.

HARDWARE INFORMATION

This bulletin contains a variety of information related to the installation and operation of the Operator Interface supplied. Ideally, you should read this document thoroughly before attempting to use the equipment. For information about the software aspects of the terminal, please consult other documentation.

CONTENTS OF PACKAGE

The Operator Interface is supplied in a packaging box containing the following...

- ◆ The interface terminal itself.
- ◆ A NEMA 4/IP65 rated mounting gasket.
- ◆ A bag containing panel hardware.
- ◆ This hardware bulletin.
- ◆ Inspection Load Utility plus EDICT driver and application note.
- ◆ If any of these items are missing, please contact your supplier immediately.

POWER SUPPLY REQUIREMENTS

The Operator Interface requires an 11 to 30 VDC power supply rated at 2.5 W unless otherwise stated on the label.

- ◆ The terminal may take as little as 100 mA in certain circumstances, so be sure that the chosen power supply can operate correctly with this load. Large switch-mode supplies tend to need a certain minimum load before they will operate correctly.

In any case, it is very important that the power supply is mounted correctly if the unit is to operate reliably. A very high proportion of reported problems are caused by incorrect power supply installation, so please take care to observe the following points...

- ◆ The power supply must be mounted close to the unit, with usually not more than 6 feet of cable between the supply and the Operator Interface. Ideally, as short a length as is possible should be used.
- ◆ The wire used to connect the Operator Interface's power supply should be of at least 22 gage wire. If a longer cable run is used, you should use heavier gage wire. The routing of the cable should be kept away from large contactors, inverters and other devices which may generate significant electrical noise.

BATTERY BACKUP ISSUES

The Operator Interface is supplied with a Lithium Battery designed to maintain the internal memory and real-time clock during power outages. Assuming the operator interface terminal is powered up for 50% of the time, this battery should last over 4 years. A "Battery Low" system variable is available so that the programmer can choose specific action(s) to occur when the battery voltage drops below its nominal voltage.

It is possible to replace the battery without losing the contents of the Operator Interface's memory, but this does not reduce the importance of ensuring that a copy of the terminal's configuration is kept readily at hand to allow the terminal to be re-loaded in the case of mishaps. Please remember that although an image of the database contents can be uploaded, this file is not editable, so the importance of keeping a copy on disk cannot be over stressed.

CHANGING THE BATTERY

To change the internal battery, follow these steps...

- ◆ Remove the power and PLC communications connector from the unit.
- ◆ Remove the four screws from the rear cover, and remove the rear cover.
- ◆ If you wish to avoid losing the terminal's configuration, reconnect the power connector and re-apply power. Note that this will require the panel to be powered-up and, as such, only suitably qualified staff should carry out this procedure.
- ◆ The battery is located in a holder on the main circuit board. This should be clearly visible. Remove the battery from its holder.
- ◆ Place the new battery in the holder. The terminal's power supply can now be disconnected, if you re-applied power in the step above.
- ◆ Replace the lid, screws and connector by following the above procedure in reverse. You may like to make a note of the date the battery was replaced to allow planned maintenance to be carried out.
- ◆ If you did not keep the unit powered-up during battery replacement, hold down the EXIT and MUTE keys on the keyboard and cycle power. Release the keys and follow the menu guides to clear the memory. The unit is now ready for a configuration database to be reloaded.

Please note that the old battery must be disposed of in a manner which complies with your local waste regulations. Also, the battery must not be disposed of in fire or in a manner whereby it may be damaged and its contents come into contact with human skin.

INSTALLATION & CONNECTIONS

The unit meets NEMA 4/IP65 requirements for indoor use, when properly installed. The units are intended to be mounted into an enclosed panel.

Installation Environment

The unit should be installed in a location that does not exceed the maximum operating temperature and provides good air circulation. Placing the unit near devices that generate excessive heat should be avoided.

Continuous exposure to direct sunlight may accelerate the aging process of the bezel. The bezel should be cleaned only with a soft cloth and neutral soap product. Do NOT use solvents.

Do not use tools of any kind (screwdrivers, pens, pencils, etc.) to operate the keypad of the unit.

MOUNTING INSTRUCTIONS

The Operator Interfaces are designed for through-panel mounting. A neoprene gasket is provided, to enable sealing to NEMA 4/IP65 specification. The panel cut-out diagram for the model supplied is provided. All mounting holes should be drilled for 0.14" (3.5 mm) clearance. Care should be taken to remove any loose material from the mounting hole to avoid such metal falling into the Operator Interface itself during installation.

CONNECTING TO A PLC

The Operator Interface is designed to operate with a PLC. A serial communication connection must be made between the operator interface terminal and PLC, and the details of this connection vary according to which PLC is used.

The following section lists the connection details for the PLC to be used .

PLC TYPE

Details on how to connect to most PLCs are available on request from RLC.

CONNECTING TO AN IBM® PC/AT

The Operator Interface is programmed via software running on an IBM PC/AT or a compatible computer. The connection between the PC/AT and the operator interface terminal is made via a custom cable provided with the EDICT Developer's Kit. The cable is designed for a 9-way serial port. Please contact your supplier if you require a 25-way version.

PROGRAMMING PORT PIN OUT

The Operator Interface's programming port is sometimes used to connect other RS-232 devices, such as printers. The following illustration and table gives the pin-out of this port to enable such connections to be made.

RJ11 FEMALE	
PIN	NAME
1	RTS
2	Tx
3	GND
4	GND
5	Rx
6	CTS

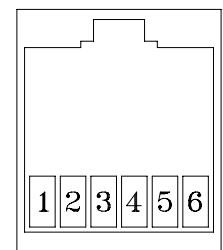

Rear View of Unit

The above table denotes the pin names of the programming port. When connecting, the pin name at the programming port is connected to the opposite of that pin name at the destination device.

TROUBLESHOOTING

For further technical assistance, contact technical support at the appropriate company numbers listed.

© 2001, RED LION CONTROLS, ALL RIGHTS RESERVED.

Information in this document is subject to change without notice and does not represent a commitment by Red Lion Controls. Software, which includes any database supplied therewith, described in this document may be furnished subject to a license agreement or a nondisclosure agreement. It is against the Law to copy the software except as specifically allowed in the license or nondisclosure agreement. No part of this document may be reproduced in any form or by any means, electronic or mechanical, including photocopying and recording, for any purpose, without the express written permission of Red Lion Controls.

PowerPoint and Windows are registered trademarks of Microsoft Corporation. Other product and company names mentioned herein may be the trademarks of their respective owners.

Disclaimer

Red Lion Controls, hereinafter referred to as RLC, will under no circumstances be responsible for direct, indirect, special, incidental or consequential damages, death or personal injury arising from the use or misuse of all or part of this documentation or the products and software described herein. Notwithstanding the above, RLC does not exclude any liability for death or personal injury caused by its negligence.

RLC does not warrant any of its software products to be free from error or to be fit for any particular purpose. Neither is the software guaranteed to provide operation without interruption. The customer's sole remedy in case of failure is the refund of the purchase price of the software.

The customer, in applying the products and software described herein, accepts that the products are wholly or partly programmable electronic systems that are inherently complex and which cannot thus be guaranteed to be free of errors. In doing so, the customer accepts the responsibility to ensure that the products are correctly programmed, configured, installed, commissioned, operated and maintained by competent and suitably trained staff and according to any instructions or safety instructions provided and as dictated by good engineering practices.

This documentation, and the software and products described herein, is subject to continuous development and improvement. All information is given in good faith, but RLC shall not be liable for any omissions or errors herein or within the software herein described.