

MODEL LNXT1 - SINGLE PRESET TIMER MODEL LNXT2 - DUAL PRESET TIMER

- 0.3" (7.6 mm) HIGH, 6 DIGIT DISPLAY
- UP/DOWN TIMING CAPABILITY
- DISPLAY SCROLLING (SELECTABLE)
- RELAY OUTPUT(S)
- SOLID-STATE CURRENT SINKING OUTPUT(S)
- PROGRAMMABLE TIMED OUTPUT(S) REMOTE RESET CAPABILITY
- SIMPLIFIED FRONT PANEL PROGRAMMING
- ABILITY TO LOCK OUT FRONT PANEL FUNCTIONS
- ON-LINE SELF-TEST
- AVAILABLE IN AC OR DC POWERED VERSIONS
- 4 TIME RANGES
 0.01 SECONDS
 0.01 MINUTES
 0.001 SECONDS
 0.001 MINUTES



- SEALED FRONT PANEL CONSTRUCTION (NEMA 4X/IP65)
- NON-VOLATILE MEMORY (E²PROM)

DESCRIPTION

The Lynx Series of presettable timers is an economical and reliable solution to single or dual preset level requirements. The Model LNXT1 is the single preset version and the Model LNXT2 is the dual preset version. Both units have a solid-state output and a Form C relay output for each preset. These units feature a full compliment of control inputs, programmable timed outputs, non-volatile memory, and many other features that satisfy most any single or dual preset application.

The Lynx Timer has two main timing actions, Reset to Zero (RTZ) and Reset to Preset (RTP). There are eight modes of operation for the single preset unit and sixteen for the dual preset unit.

All parameters are programmed through the front panel buttons. The Lynx timers have an internal non-volatile memory device which eliminates the need for battery back-up. When power is removed or interrupted, this device maintains all data set-ups necessary for system operation. A Program Disable terminal is provided, which prevents accidental changes or tampering by unauthorized personnel to the preset(s) or timed output values. The front panel reset button can be enabled or disabled by a rear panel DIP switch. These timers have an on-line self-test which can be run at any time without losing time or missing a preset value.

Power, input, and output connections are made via removable terminal blocks at the rear of the unit. DIP switches at the rear of the unit are used to set the desired mode of operation and time ranges.

The Lynx Series of timers have a sealed high impact plastic bezel and meet NEMA 4X/IP65 specifications for wash-down and/or dust, when properly installed.

SAFETY SUMMARY

All safety related regulations, local codes and instructions that appear in the manual or on equipment must be observed to ensure personal safety and to prevent damage to either the instrument or equipment connected to it. If equipment is used in a manner not specified by the manufacturer, the protection provided by the equipment may be impaired.

Do not use this unit to directly command motors, valves, or other actuators not equipped with safeguards. To do so, can be potentially harmful to persons or equipment in the event of a fault to the unit.



CAUTION: Read complete instructions prior to installation and operation of the unit.



CAUTION: Risk of electric shock.

DIMENSIONS In inches (mm)

Note: Recommended minimum clearance (behind the panel) for mounting clip installation is 2.7" (68.6)H x 4.0" (101.6)W.

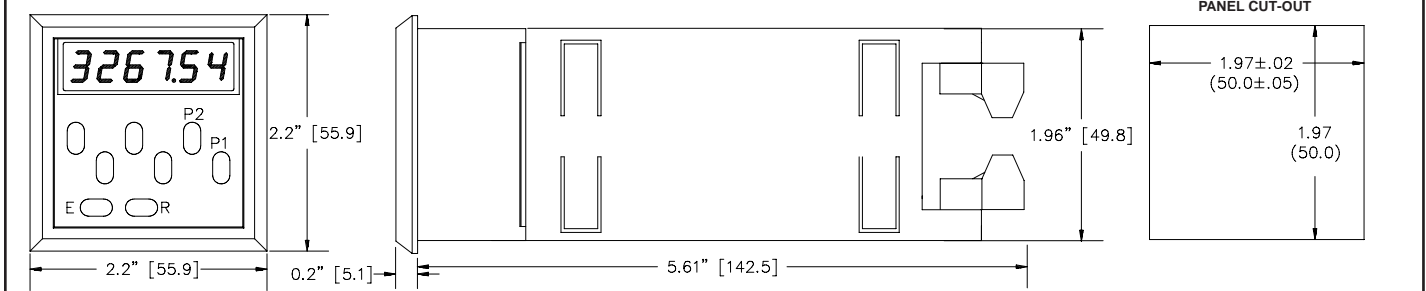

BLOCK DIAGRAM

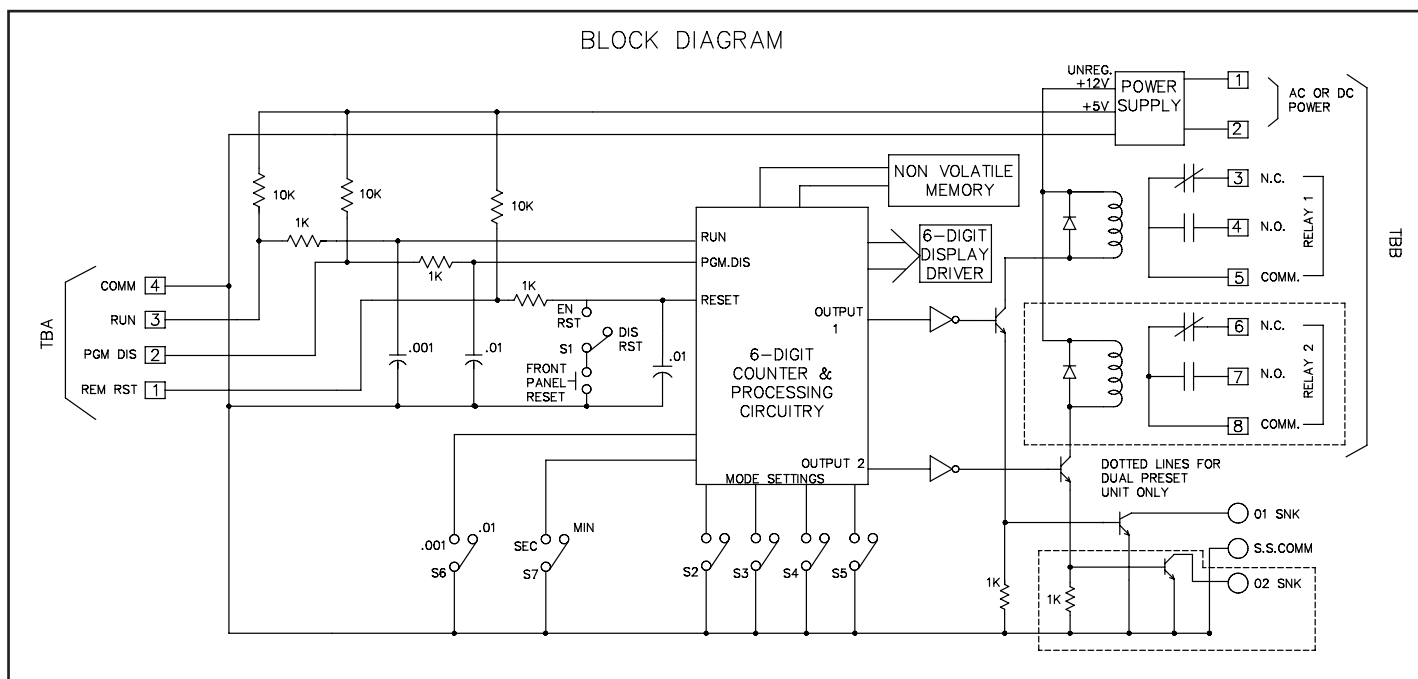

SPECIFICATIONS

- DISPLAY:** 6-digit, 0.3" (7.6 mm) high LCD display.
- POWER REQUIREMENTS:**
 - AC Power Versions:** 115 VAC ($\pm 10\%$), 50/60 Hz, 6 VA
230 VAC ($\pm 10\%$), 50/60 Hz, 6 VA
 - DC Power Versions:** 11 to 14 VDC @ 100 mA.
21.5-30 VDC @ 100 mA.
- RUN INPUT:** Accepts switch contact closures and NPN open collector outputs and similar types of current sinking inputs.
 $V_{IL} = 0.5$ V max., $V_{IH} = 2.2$ V min., internally pulled up to 5 VDC through a 10 K Ω resistor ($I_{SNK} = 0.5$ mA). Response time = 1 msec. (These units operate with VCM E through H modules)
- TIME ACCURACY:** $\pm 0.01\%$
- TIME RANGES:**

Time	Max. Display
0.01 sec	9999.99
0.001 sec	999.999
0.01 min	9999.999
0.001 min	999.999
- CONTROL INPUTS:** Active low ($V_{IL} = 0.5$ V max., $V_{IH} = 2.2$ V min.), internally pulled up to 5 VDC through a 10 K Ω resistor ($I_{SNK} = 0.5$ mA).
 - Remote Reset:** Response time = 10 msec. A low resets the unit and deactivates outputs.
 - Program Disable:** A low inhibits the changing of presets and timed outputs, as well as testing outputs in self-test.
- OUTPUTS:**
 - Solid-State:** Current sinking NPN open collector transistors.
 $I_{SNK} = 100$ mA max., $V_{OH} = 30$ VDC_{MAX.}, $V_{OL} = 1$ V @ 100 mA.
 - Relay:** Form C contacts max. rating 5 amps @ 120/240 VAC, 28 VDC (resistive load), 1/8 H.P. @ 120 VAC (inductive load). The operate time is 5 msec. nominal and the release time is 3 msec. nominal.
 - Relay Life Expectancy** - 100,000 cycles at max. rating. (As load level decreases, life expectancy increases.)
 - Programmable Timed Output:** The timed output can be programmed from 0.01 sec. to 99.99 sec., $\pm 0.1\%$ + 10 msec. max.
- MEMORY RETENTION:** Non-volatile E²PROM retains all programmed information when power is removed or interrupted.
 - Power Cycles(ON/OFF):** 100,000 min.
 - Data Retention:** 10 years min.
- INPUT, POWER, AND OUTPUT CONNECTIONS:** Removable terminal blocks.
- ENVIRONMENTAL CONDITIONS:**
 - Operating Temperature Range:** 0 to 50°C
 - Storage Temperature Range:** -40 to 70°C
 - Operating and Storage Humidity:** 85% max. relative humidity (non-condensing) from 0°C to 50°C.
 - Altitude:** Up to 2000 meters

11. CERTIFICATIONS AND COMPLIANCES:

SAFETY:

IEC 1010-1, EN 61010-1: Safety requirements for electrical equipment for measurement, control, and laboratory use. Part 1.

IP65 Enclosure rating (Face only), IEC 529
Type 4X Enclosure rating (Face only), UL50

ELECTROMAGNETIC COMPATIBILITY

Immunity to EN 50082-2

Electrostatic discharge	EN 61000-4-2	Level 2; 4 Kv contact Level 3; 8 Kv air
Electromagnetic RF fields	EN 61000-4-3	Level 3; 10 V/m 80 MHz - 1 GHz
Fast transients (burst)	EN 61000-4-4	Level 4; 2 Kv I/O
RF conducted interference	EN 61000-4-6	Level 3; 2 Kv power ¹ Level 3; 10 V/rms ¹ 150 KHz - 80 MHz

Emissions to EN 50081-2

RF interference	EN 55011	Enclosure class A Power mains class A
-----------------	----------	--

Note:

1. Power lines had an external EMI line filter, (Red Lion #LFIL0000) or equivalent, installed.

Refer to the EMC Installation Guidelines section of the manual for additional information.

- CONSTRUCTION:** High impact plastic case with clear viewing window. Front panel meets NEMA 4X/IP65 requirements for indoor use, when properly installed. Installation Category II, Pollution Degree 2. (Panel gasket, mounting clip, nut fasteners, and screws included with unit.)
- WEIGHT:** 0.8 lbs (0.36 kg).

SWITCH SET-UP

S1 - DIS.RST.: Disables front panel reset.

EN. RST.: Enables front panel reset.

S2 to S5: These are the mode select DIP switches.

See Modes of Operation for the switch settings of a specific mode.

S6 - 0.01: Sets the timer to display two decimal places.

0.001: Sets the timer to display three decimal places.

S7 - Sec.: Sets the timer to display in seconds.

Min.: Sets the timer to display in minutes.

MODES OF OPERATION, DIP SWITCH SET-UP

The DIP switches for the various operating modes are accessible from the rear of the unit.

Note: A manual reset either from the front panel reset (if enabled) or remote reset overrides any condition or state of the timer and begins the cycle again.

Note: In modes four and twelve (Single Preset) and in modes four, five, twelve, and thirteen (Dual Preset) the output may appear to be latched if the time delay is longer than the time required for the timer to reach the preset point or zero.

MODES OF OPERATION FOR SINGLE PRESET LYNX TIMER

MODE 0 LATCH OUTPUT AT PRESET, MANUAL RESET TO ZERO

The unit times from zero, when the preset value is reached, the output turns on and time continues to accumulate. When a manual reset is performed, the time resets to zero, the output turns off, and the cycle starts again.

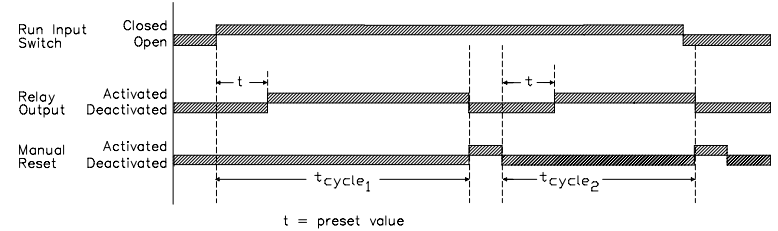
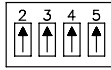

MODE 1 TIMED OUTPUT AT PRESET, MANUAL RESET TO ZERO

The unit times from zero, when the preset is reached, the output turns on for the amount of time programmed and time continues to accumulate. When a manual reset is performed, the time resets to zero and the cycle starts again.

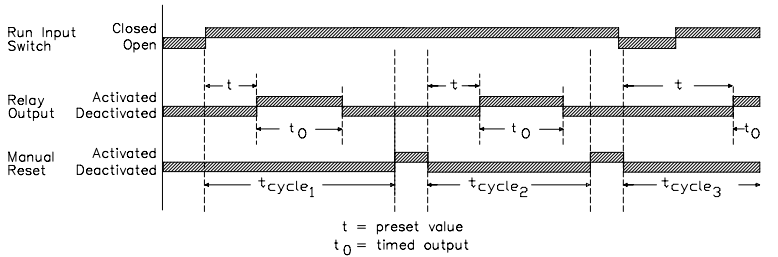
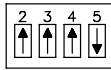

MODE 2 & 3 - ☆☆

MODE 4 TIMED OUTPUT AT PRESET, AUTOMATIC RESET TO ZERO AT PRESET

The unit times from zero, when the preset is reached, the output turns on for the amount of time programmed. At preset, the time automatically resets to zero and starts the cycle over again.

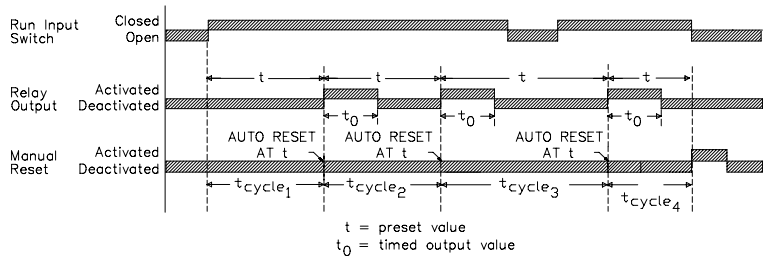
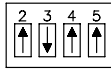

MODE 5 - ☆☆

MODE 6 TIMED OUTPUT AT PRESET, AUTOMATIC RESET TO ZERO AFTER THE TIMED OUTPUT

The unit times from zero, when the preset is reached, the output turns on for the amount of time programmed. At the end of the timed output, the time automatically resets to zero, the output turns off, and the cycle starts again.

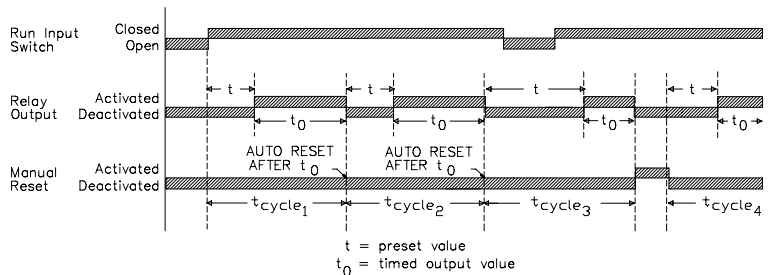
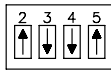

MODE 7 - ☆☆

MODE 8 LATCH OUTPUT AT ZERO, MANUAL RESET TO PRESET

The unit times down from preset, when zero is reached, the output turns on and time continues to decrement. When a manual reset is performed, the time resets to preset, the output turns off, and the cycle starts again.

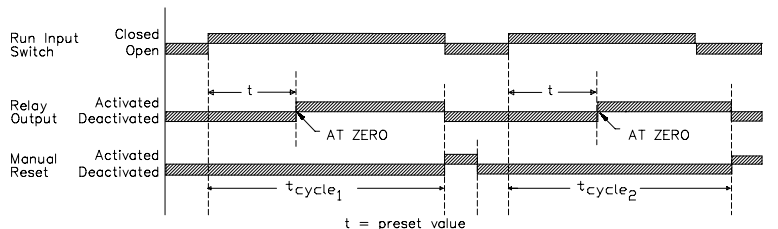
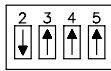

☆☆ - These modes are not applicable to the Single Preset Lynx Timer (they are used only for the Dual Preset Timer unit).

MODES OF OPERATION FOR SINGLE PRESET LYNX TIMER (Cont'd)

MODE 9 TIMED OUTPUT AT ZERO, MANUAL RESET TO PRESET

The unit times down from preset, when zero is reached, the output turns on for the amount of time programmed and time continues to decrement. When a manual reset is performed, the time resets to preset and the cycle starts again.

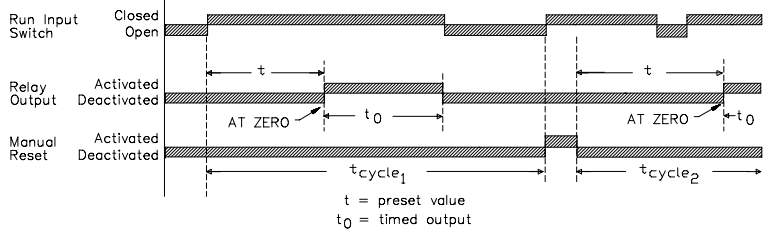

MODE 10 & 11 - ☆☆☆

MODE 12 TIMED OUTPUT AT ZERO, AUTOMATIC RESET TO PRESET AT ZERO

The unit times down from preset, when zero is reached, the output turns on for the amount of time programmed. At zero, the time automatically resets to preset and the cycle starts again.

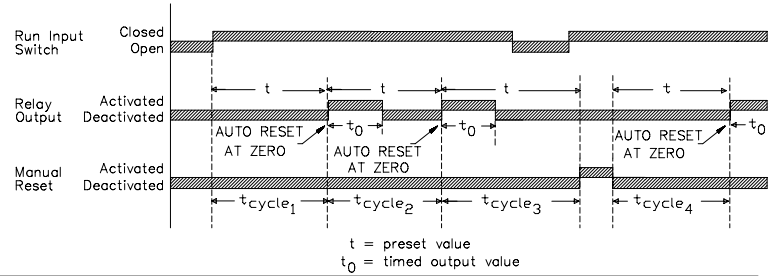
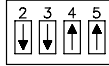

MODE 13 - ☆☆☆

MODE 14 TIMED OUTPUT AT ZERO, AUTOMATIC RESET TO PRESET AFTER THE TIMED OUTPUT

The unit times down from preset, when zero is reached, the output turns on for the amount of time programmed. At the end of the timed output, the time automatically resets to preset, the output turns off, and the cycle starts again.

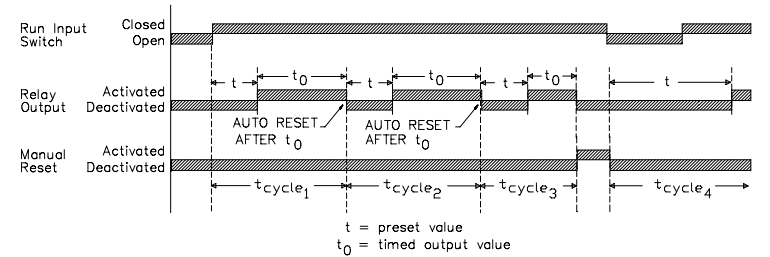
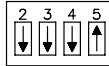

MODE 15 - ☆☆☆

☆☆ - These modes are not applicable to the Single Preset Lynx Timer (they are used only for the Dual Preset Timer unit).

MODES OF OPERATION FOR DUAL PRESET LYNX TIMER

MODE 0 LATCH OUTPUTS AT PRESET, MANUAL RESET TO ZERO

The unit times from zero, when preset 1 is reached, output 1 turns on and time continues to accumulate. When preset 2 is reached, output 2 turns on and time continues to accumulate. When a manual reset is performed, the time resets to zero, the outputs turn off, and the cycle starts again.

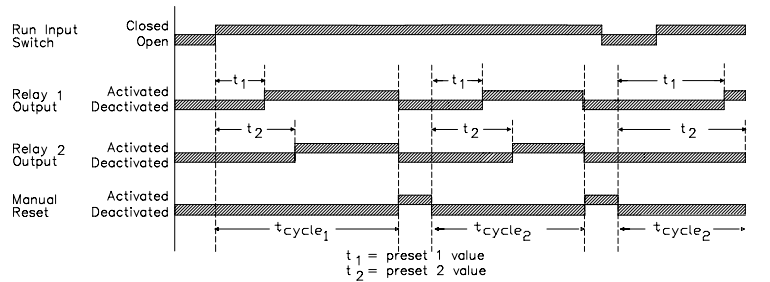

MODE 1 TIMED OUTPUTS AT PRESET, MANUAL RESET TO ZERO

The unit times from zero, when preset 1 is reached, output 1 turns on. When preset 2 is reached, output 2 turns on. Time continues to accumulate after the preset levels have been reached. The outputs turn off after their respective programmed time values. When a manual reset is performed, the time resets to zero and the cycle starts again.

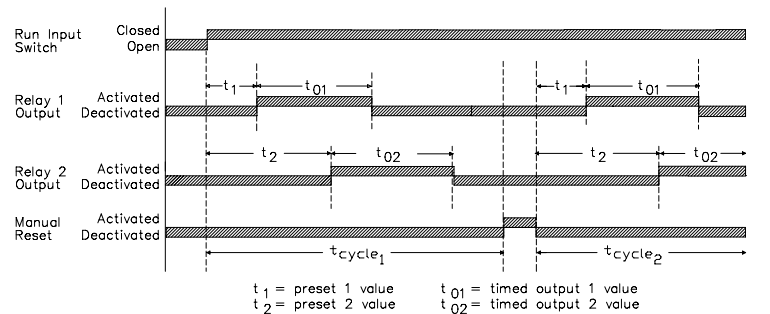
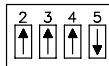

MODES OF OPERATION FOR DUAL PRESET LYNX TIMER (Cont'd)

MODE 2 OUTPUT 1 TURN OFF AT PRESET 2, LATCH OUTPUT 2 AT PRESET 2, MANUAL RESET TO ZERO

The unit times from zero, when preset 1 is reached, output 1 turns on. When preset 2 is reached, output 1 turns off, and output 2 turns on. Time continues to accumulate after the preset levels have been reached. Output 2 remains on until a manual reset occurs. Manual reset turns off both outputs, the time resets to zero, and the cycle starts again.

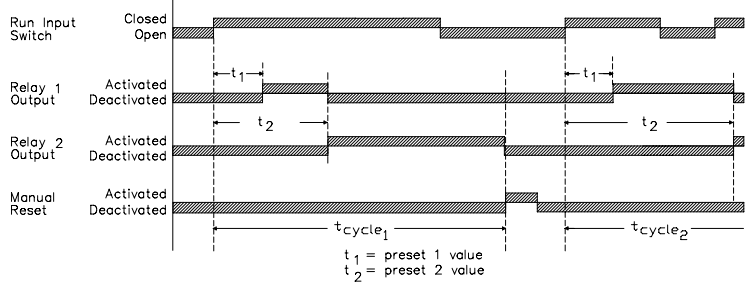
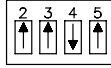

MODE 3 OUTPUT 1 TURN OFF AT PRESET 2, TIMED OUTPUT 2 AT PRESET 2, MANUAL RESET TO ZERO

The unit times from zero, when preset 1 is reached, output 1 turns on. When preset 2 is reached, output 1 turns off and output 2 turns on for the amount of time programmed. Time continues to accumulate after the preset levels have been reached. When a manual reset is performed, the time resets to zero, and the cycle starts again.

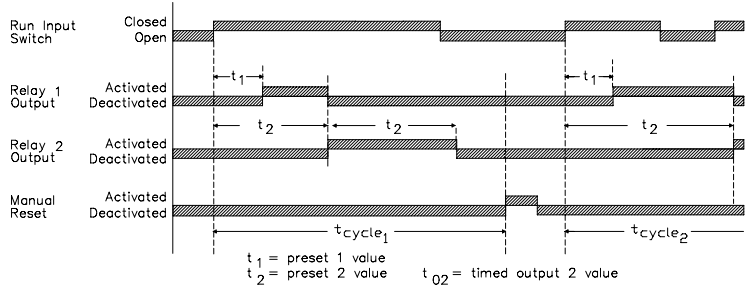
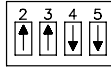

MODE 4 OUTPUT 1 TURN OFF AT PRESET 2, TIMED OUTPUT 2 AT PRESET 2, AUTOMATIC RESET TO ZERO AT PRESET 2

The unit times from zero, when preset 1 is reached, output 1 turns on. When preset 2 is reached, output 2 turns on for the amount of time programmed. At the beginning of timed output 2, output 1 turns off, the time automatically resets to zero, and the cycle starts again.

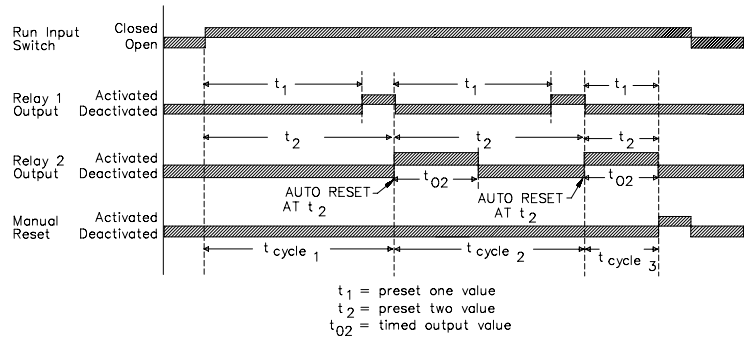
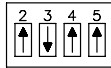

MODE 5 TIMED OUTPUTS AT PRESETS, AUTOMATIC RESET TO ZERO AT PRESET 2

The unit times from zero, when preset 1 is reached, output 1 turns on. When preset 2 is reached, output 2 turns on. The outputs turn off at the end of their respective programmed time values. At preset 2, the time automatically resets to zero and starts the cycle again.

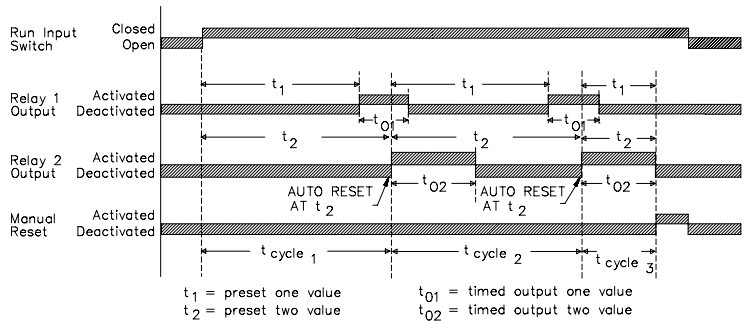
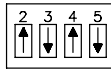

MODE 6 OUTPUT 1 TURN OFF AT PRESET 2, TIMED OUTPUT 2 AT PRESET 2, AUTOMATIC RESET TO ZERO AFTER TIMED OUTPUT 2

The unit times from zero, when preset 1 is reached, output 1 turns on. When preset 2 is reached, output 1 turns off and output 2 turns on for the amount of time programmed. At the end of timed output 2, the time automatically resets to zero and starts the cycle again.

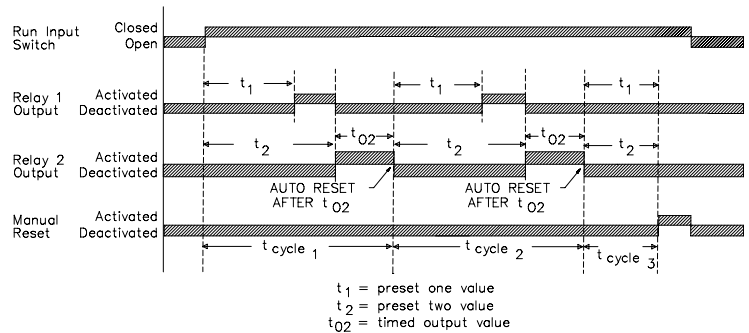
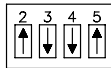

MODES OF OPERATION FOR DUAL PRESET LYNX TIMER (Cont'd)

MODE 7 TIMED OUTPUTS AT PRESETS, AUTOMATIC RESET TO ZERO AFTER TIMED OUTPUT 2

The unit times from zero, when preset 1 is reached, output 1 turns on. When preset 2 is reached, output 2 turns on. The outputs turn off at the end of their respective programmed time values. At the end of timed output 2, the time automatically resets to zero, and starts the cycle again.

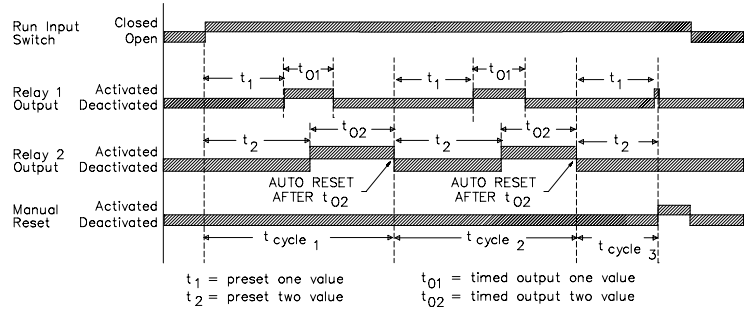
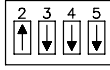

MODE 8 LATCH OUTPUT AT PRESET 1 AND ZERO, MANUAL RESET TO PRESET 2

The unit times down from preset 2, when preset 1 is reached, output 1 turns on, when zero is reached, output 2 turns on. Time continues to decrement after the preset levels have been reached. When a manual reset is performed, the time resets to preset 2, the outputs turn off, and the cycle starts again.

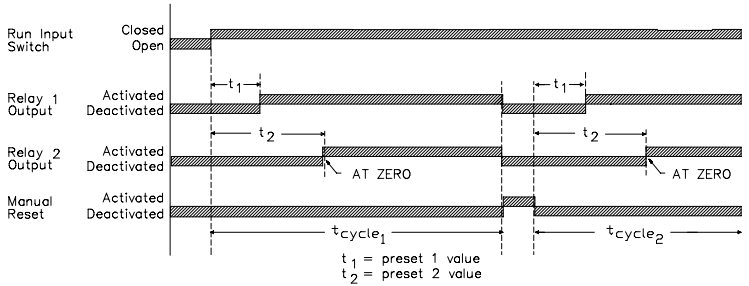
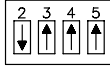

MODE 9 TIMED OUTPUT AT PRESET 1 AND ZERO, MANUAL RESET TO PRESET 2

The unit times down from preset 2, when preset 1 is reached, output 1 turns on. When zero is reached, output 2 turns on. The outputs turn off when their respective programmed time values end. Time continues to decrement after the preset levels have been reached. When a manual reset is performed, the time resets to preset 2, and the cycle starts again.

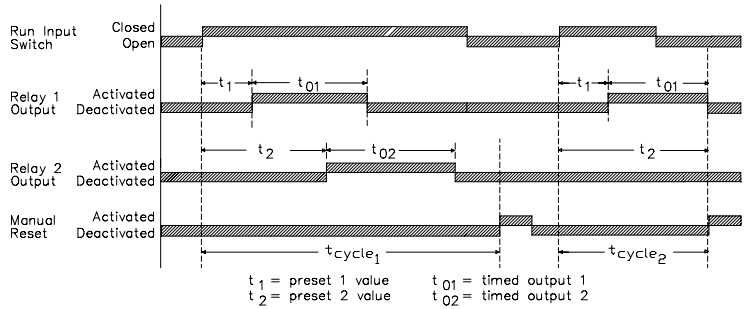
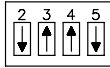

MODE 10 OUTPUT 1 TURN OFF AT ZERO, LATCH OUTPUT 2 AT ZERO, MANUAL RESET TO PRESET 2

The unit times down from preset 2, when preset 1 is reached, output 1 turns on. When zero is reached, output 2 turns on and output 1 turns off. Output 2 remains on until a manual reset is performed. Time continues to decrement after preset levels are reached. Manual reset turns off both outputs, if activated, the time resets to preset 2, and the cycle starts again.

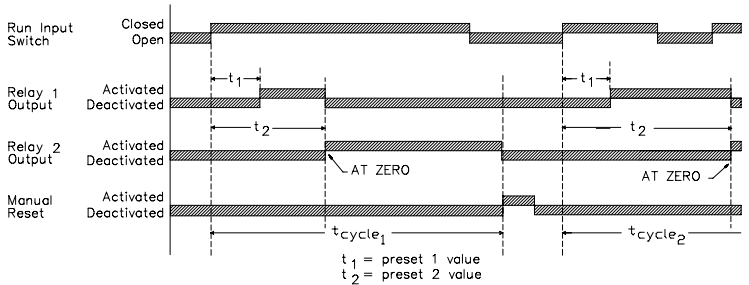
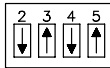

MODE 11 OUTPUT 1 TURN OFF AT ZERO, TIMED OUTPUT 2 AT ZERO, MANUAL RESET TO PRESET 2

The unit times down from preset 2, when preset 1 is reached, output 1 turns on. When zero is reached, output 1 turns off and output 2 turns on for the amount of time programmed. Time continues to decrement after the preset levels have been reached. When a manual reset is performed, the time resets to preset 2, and the cycle starts again.

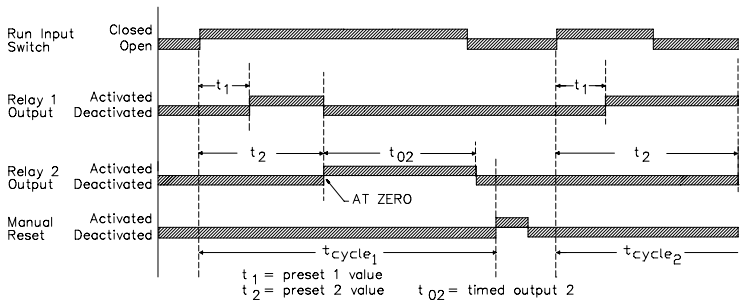
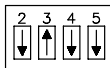

MODES OF OPERATION FOR DUAL PRESET LYNX TIMER (Cont'd)

MODE 12 OUTPUT 1 TURN OFF AT ZERO, TIMED OUTPUT 2 AT ZERO, AUTOMATIC RESET TO PRESET 2 AT ZERO

The unit times down from preset 2, when preset 1 is reached, output 1 turns on. When zero is reached, output 2 turns on for the amount of time programmed, output 1 turns off, and the time automatically resets to preset 2.

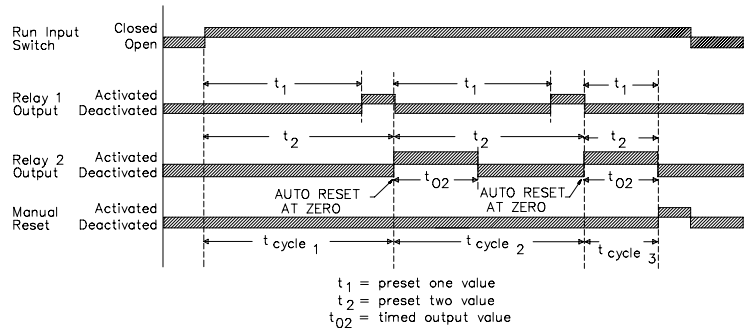
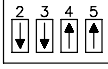

MODE 13 TIMED OUTPUTS AT PRESET 1 AND ZERO, AUTOMATIC RESET TO PRESET 2 AT ZERO

The unit times down from preset 2, when preset 1 is reached, output 1 turns on. When zero is reached, output 2 turns on. The outputs turn off at the end of their respective programmed time values. At zero, the time automatically resets to preset 2 and the cycle starts again.

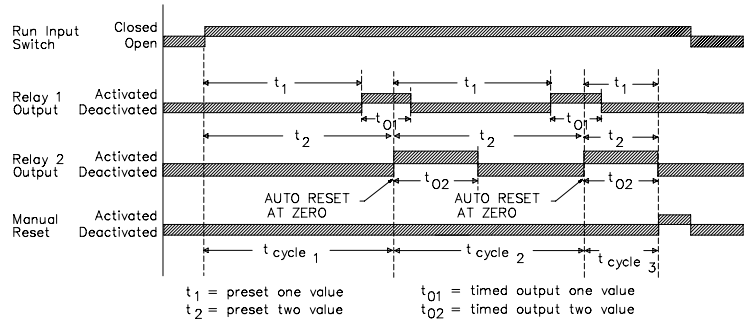
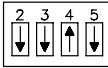

MODE 14 OUTPUT 1 TURN OFF AT ZERO, TIMED OUTPUT 2 AT ZERO, AUTOMATIC RESET TO PRESET 2 AFTER TIMED OUTPUT 2

The unit times down from preset 2, when preset 1 is reached, output 1 turns on. When zero is reached, output 1 turns off and output 2 turns on for the amount of time programmed. At the end of timed output 2, the time automatically resets to preset 2, and the cycle starts again.

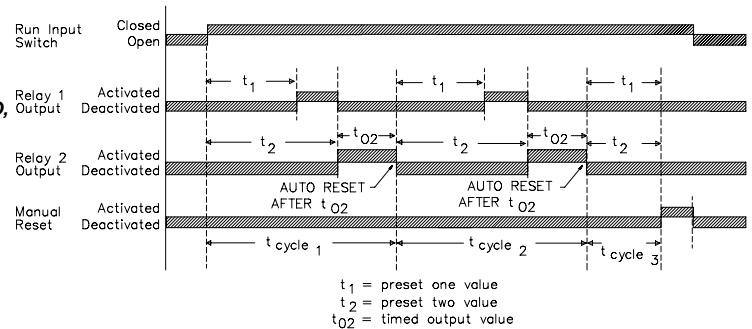
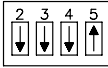

MODE 15 TIMED OUTPUTS AT PRESET 1 AND ZERO, AUTOMATIC RESET TO PRESET 2 AFTER TIMED OUTPUT 2

The unit times down from preset 2, when preset 1 is reached, output 1 turns on. When zero is reached, output 2 turns on. The outputs turn off at the end of their respective programmed time values. At the end of timed output 2, the time automatically resets to preset 2 and the cycle starts again.

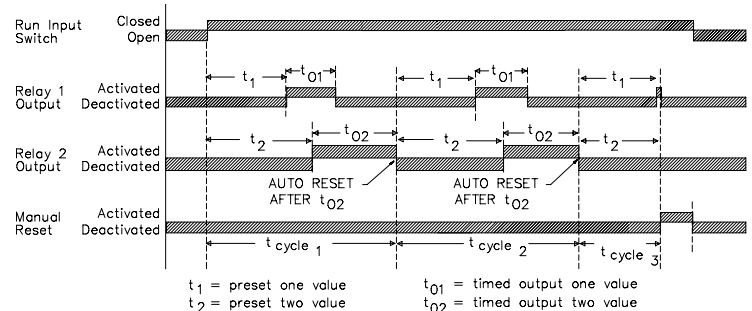
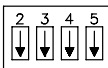

POWER-UP DIAGNOSTICS

Upon applying power, the Lynx Timer performs an internal self-diagnostic test of all the stored data. If the tests do not agree, a "P" appears on the right side of the display. Normal operation of the unit will continue while the "P" is displayed. Press the "E" button to remove the "P" and check all data set-up values to be certain they are correct.

EMC INSTALLATION GUIDELINES

Although this unit is designed with a high degree of immunity to ElectroMagnetic Interference (EMI), proper installation and wiring methods must be followed to ensure compatibility in each application. The type of the electrical noise, source or coupling method into the unit may be different for various installations. The unit becomes more immune to EMI with fewer I/O connections. Cable length, routing and shield termination are very important

and can mean the difference between a successful or a troublesome installation. Listed below are some EMC guidelines for successful installation in an industrial environment.

1. Use shielded (screened) cables for all Signal and Control inputs. The shield (screen) pigtail connection should be made as short as possible. The connection point for the shield depends somewhat upon the application. Listed below are the recommended methods of connecting the shield, in order of their effectiveness.
 - a. Connect the shield only at the panel where the unit is mounted to earth ground (protective earth).
 - b. Connect the shield to earth ground at both ends of the cable, usually when the noise source frequency is above 1 MHz.
 - c. Connect the shield to common of the unit and leave the other end of the shield unconnected and insulated from earth ground.

EMC INSTALLATION GUIDELINES (cont'd)

- Never run Signal or Control cables in the same conduit or raceway with AC power lines, conductors feeding motors, solenoids, SCR controls, and heaters, etc. The cables should be run in metal conduit that is properly grounded. This is especially useful in applications where cable runs are long and portable two-way radios are used in close proximity or if the installation is near a commercial radio transmitter.
- Signal or Control cables within an enclosure should be routed as far away as possible from contactors, control relays, transformers, and other noisy components.
- In extremely high EMI environments, the use of external EMI suppression devices, such as ferrite suppression cores, is effective. Install them on Signal and Control cables as close to the unit as possible. Loop the cable through the core several times or use multiple cores on each cable for additional protection. Install line filters on the power input cable to the unit to suppress power line interference. Install them near the power entry point of the enclosure. The following EMI suppression devices (or equivalent) are recommended:

Ferrite Suppression Cores for signal and control cables:

Fair-Rite # 0443167251 (RLC #FCOR0000)

TDK # ZCAT3035-1330A

Steward #28B2029-0A0

Line Filters for input power cables:

Schaffner # FN610-1/07 (RLC #LFIL0000)

Schaffner # FN670-1.8/07

Corcom #1VB3

Corcom #1VR3

Note: Reference manufacturer's instructions when installing a line filter.

- Long cable runs are more susceptible to EMI pickup than short cable runs. Therefore, keep cable runs as short as possible.
- Switching of inductive loads produces high EMI. Use of snubbers across inductive loads suppresses EMI.
Snubbers:
RLC #SNUB0000

WIRING CONNECTIONS

All conductors should meet voltage and current ratings for each terminal. Also cabling should conform to appropriate standards of good installation, local codes and regulations. It is recommended that power supplied to the unit (AC or DC) be protected by a fuse or circuit breaker.

When wiring the unit, remove the terminal block and use the numbers on the label to identify the position number with the proper function. Strip the wire, leaving approximately 1/4" bare wire exposed (*stranded wires should be tinned with solder*). Insert the wire into the terminal and tighten down the screw until the wire is clamped tightly. Each terminal can accept up to one 14-gauge, two 18-gauge or four 20-gauge wire(s). After the terminal block is wired, install it into the proper location on the PC board. Wire each terminal block in this manner.

Caution: Terminal blocks should **NOT** be removed with power applied to the unit.

INPUT CONNECTIONS

Input connections are made on terminal block TBA. Refer to numbers on the label to identify the position number with the proper function. (*The input connections are the same for single or dual preset timers.*)

Terminal 1 - "REM.RST." (remote reset) When low (0.5 V_{MAX}), a manual reset is performed. The output(s) turn off (*if activated*) and the time display is reset. As long as this terminal is low, the unit is held at reset.

Terminal 2 - "PGM.DIS." (program disable) When this terminal is left open(unconnected), the following values can be programmed using the front panel buttons:

Preset Value(s)
Timed Output Value(s)

Outputs can also be tested during self-test under this condition (See Self-Test description for further details). When terminal is low (0.5 V_{MAX}), changing these values and testing the outputs is no longer possible.

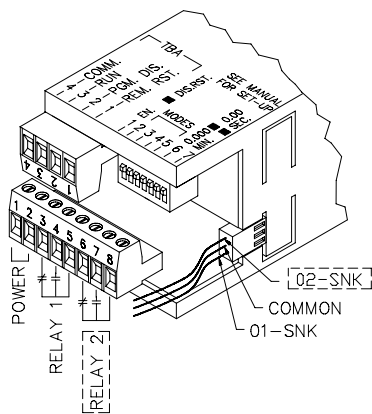

Terminal 3 - "RUN" When this terminal is connected to common, time is registered.

Terminal 4 - "COMM." (common) Is the common line to which the sensor and other input commons are connected. (*Do NOT connect relay commons or solid-state output commons to this point.*)

POWER & OUTPUT CONNECTIONS

The input power and relay output connections are made to the bottom terminal block (TBB), and the solid-state outputs are connected to the polarized three-pin connector.

AC POWER WIRING

Primary AC power is connected to terminals 1 and 2 of TBB (marked VAC 50/60 Hz). To reduce the chance of noise spikes entering the AC line and affecting the unit, the power should be relatively "clean" and within the ±10% variation limit. Drawing power from heavily loaded circuits, or from circuits that also power loads that cycle on and off (contactors, relays, motors, machinery, etc.), should be avoided.

DC POWER WIRING

The DC power is connected to terminals 1 and 2 of TBB. The DC plus(+) power is connected to TBB 1 and the minus(-) is connected to TBB 2.

USER INPUT WIRING

Internal user inputs PGM DIS and REM RST are digital inputs that are active when connected to TB #4 Common. The use of shielded cable is recommended. Follow the EMC Installation Guidelines for shield connection.

OUTPUT WIRING

Relay Connections

To prolong contact life and suppress electrical noise interference due to the switching of inductive loads, it is good installation practice to install a snubber (RLC #SNUB0000) across the contactor. Follow the manufacturer's instructions for installation.

When switching an inductive load with solid state outputs, it is recommended that an EMI device such as a snubber be installed at the load.

Note: Snubber leakage current can cause some electro-mechanical devices to be held ON.

Terminals 3, 4, and 5 of TBB are used to connect to output relay 1. Terminals 6, 7, and 8 of TBB (dual preset only) are used to connect to output relay 2 (Refer to block diagram).

SOLID-STATE CONNECTIONS

The solid-state output connector has three wires (two wires for the single preset unit) for connections.

Yellow wire - Solid-state output 1 (labeled 01 SNK.). Internally connects to an NPN open collector transistor.

Black wire - Common for the solid-state output(s). This terminal should **NOT** be used as the common for the input or control terminals.

Blue wire (dual preset only) - Solid-state output 2 (labeled 02 SNK.). Internally connects to an NPN open collector transistor.

FRONT PANEL FUNCTION DESCRIPTION

These units employ eight front panel buttons for control and data entering. The button functions are as described below:

RESET "R": Resets the timer to either zero or preset, depending on the mode of operation selected. For this button to operate, the enable/disable reset DIP switch at the rear of the unit must be set to the enable (EN.) position. The reset button is also used in conjunction with the preset button(s), to view and change the timed output value(s). When reset is activated, all processes are stopped or interrupted (i.e. outputs turn off, display is reset). This is the case under any mode of operation, in any data entry mode.

PRESET "P1" ("P2"): Labeled P1 and P2 (single preset units only have the P1 preset button).

The preset 1 value is displayed when the P1 button is pressed, and the Preset Value mode is accessed (See Program Preset Value). The value remains displayed for approximately 10 seconds after the button is released.

The preset buttons are also used, in conjunction with the reset button, to view and change the timed output values (See Program Timed Output Value.)

ENTER "E": The Enter button is used when programming the Preset Value or the Timed Output Value. After the desired value is obtained on the display, pressing the E button enters the value into the unit's internal memory and takes effect immediately. Also the "E" button can be used to exit self-test.

DISPLAY SCROLLING

To set the display to scroll, press and hold the “E” button and then press the left-most button on the front panel. To stop the scrolling, repeat the above step.

DISPLAY SCROLLING SEQUENCE

Single Preset	Dual Preset
P1	P1
Value of P1	Value of P1
Time Value	P2
	Value of P2
	Time Value

PROGRAM PRESET VALUE *

The factory default values are set to 5.00 for preset 1 and 10.00 for preset 2. To enter a different value, the operator must enter the Preset Value Programming Mode by performing the following steps.

Note: During the displaying, changing, and entering of a new preset value, all functions of the unit are operational (i.e. timing, resetting, outputs activating, etc.)

FIRST: Press “P1”, (or “P2” if a dual preset unit). This displays the respective preset value, which remains displayed for approximately 10 seconds after release of the last button pushed. At this time, the preset display mode can be exited, without change, by pressing the “E” button.

SECOND: Once the preset value is displayed, a specific digit can be incremented by pressing the button directly beneath that digit. Pressing and holding the button down will continuously scroll the digit from 0 through 9, then back to 0 again. When the desired value for that digit is reached, release the button. Repeat this step until the desired preset value is obtained.

THIRD: Press the “E” button to enter the value into the unit’s memory. As Soon As the “E” button is pressed, the new preset value takes effect. If the “E” button is not pressed within 10 seconds, the unit returns to normal display operation with the previous value retained.

* - To enter any new data into the Lynx, the “PGM.DIS.” terminal must be open or at 5 V maximum.

PROGRAM TIMED OUTPUT VALUE *

The factory default Timed Output Value is 0.10 seconds, but can be programmed from 0.01 to 99.99 seconds. To enter a different value, the operator must enter the Timed Output Value Programming Mode by performing the following steps.

Note: During the displaying, changing, and entering of a new timed output value, all functions of the unit are operational (i.e. timing, resetting, outputs activating, etc.)

FIRST: Set S1 Reset EN./DIS. switch to the DOWN position (Enable).

SECOND: Press and hold the “P1”, (or “P2” button if a dual preset unit) and then press the “R” button. The respective timed output value is displayed and remains displayed for approximately 10 seconds after release of the last button pushed. At this time, the timed output display mode can be exited, without change, by pressing the “E” button.

THIRD: Once the timed output value is displayed, a specific digit can be incremented by pressing the button directly beneath that digit. Pressing and holding the button down will continuously scroll the digit from 0 through 9, then back to 0 again. When the desired value for that digit is reached, release the button. Repeat this step until the desired timed output value is obtained.

FOURTH: Press the “E” button to enter the value into the unit’s memory. As Soon As the “E” button is pressed, the new timed output value takes effect, if the output is not active at that time. If the output is active at the time of the change, the new value will take effect the next time the output is activated. If the “E” button is not pressed within 10 seconds, the unit returns to normal display operation with the previous value retained.

* - To enter any new data into the Lynx, the “PGM.DIS.” terminal must be open or at 5 V maximum.

SELF-TEST

The self-test feature can be activated without affecting the time, missing a preset point, affecting the timed output durations, or interfering with control functions. This test verifies that all digits operate. Also, the DIP switch settings and the relay outputs can be tested.

If the outputs are not tested, the state(s) of the output(s) remain the same as they were prior to self-test. If the outputs are tested in self-test, the outputs will be off after exiting self-test.

Rapid advance of the self-test routine can be done by pressing and releasing any of the front panel buttons except for the “R” button. (Pressing “R” at any time, except when entering the timed output mode, resets the unit.)

To enter self-test, press the two left-hand digit buttons (on the front panel) simultaneously. At this time, the display will cycle all the digits each for about half a second in the sequence shown.

DIGITS CYCLED ON THE DISPLAY

000000
111111
222222
333333
444444
555555
666666
777777
888888
999999
BLANK DISPLAY
101010
121212
323232
343434
545454
565656
767676
787878
989898

The next portion of self-test displays a group of four ones and zeros. The two left-most digits represent the setting of the timer mode DIP switches, with the first being min/sec and the second being .001T/.01T. The third digit always shows a zero. The fourth digit represents program disable (PGM.DIS). A zero represents a high at this terminal and a one represents a low. The second set of digits are the settings of the mode select DIP switches (S2 to S5 at the rear of the unit). This pattern directly corresponds to the number representing the mode of operation. If the switches are changed while at this point in the self-test, the settings can be seen to change. These changes do not affect timer operation immediately, but any changes take effect when the self-test is exited. When the switch is “DOWN”, the digit shows a one. When the switch is “UP”, the digit shows a zero.

When the mode switch settings are displayed, the outputs can be tested. To activate the output(s), press “P1” for output 1 or “P2” for output 2. If no testing of the output(s) is required, press the “E” button until the unit exits self-test (the unit returns to normal display mode). Also, if no activity occurs on the switches or the front panel button within 18 seconds after the unit pauses at the mode switch display, the unit automatically exits self-test.

Note: The “PGM.DIS.” terminal must be open for the outputs to be activated. Caution: The operator should use care when testing the outputs, so as not to cause any undesirable or hazardous conditions in the system.

FACTORY SETTINGS

The following are the values set when shipped from the factory.

Preset 1	=	5.00
Preset 2	=	10.00 (Dual Preset Only)
Time Value	=	0
Timed Output Value(s)	=	0.10 second

All switches are in the “UP” position except for the reset enable switch, which is “DOWN”. With the switches set in these positions, the unit is operating in mode zero (latch-on at preset, manual reset to zero). Timing is selected for seconds with two decimal places.

Installation Environment

The unit should be installed in a location that does not exceed the maximum operating temperature and provides good air circulation. Placing the unit near devices that generate excessive heat should be avoided.

The bezel should be cleaned only with a soft cloth and neutral soap product. Do NOT use solvents. Continuous exposure to direct sunlight may accelerate the aging process of the bezel.

Do Not use tools of any kind (screwdrivers, pens, pencils, etc.) to operate the keypad of the unit.

Installation

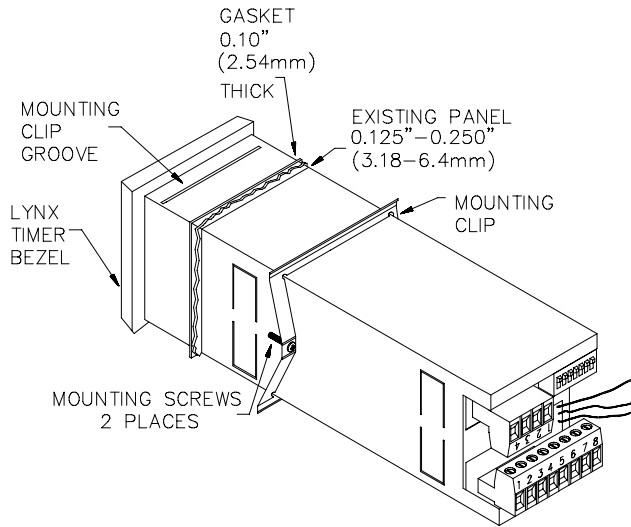

The unit meets NEMA 4X/IP65 requirements for indoor use, when properly installed. The units are intended to be mounted into an enclosed panel with a gasket to provide a water-tight seal. One mounting clip and two screws with tinnerman nuts are provided for easy installation. Consideration should be given to the thickness of the panel. Too thin of a panel may distort and not provide a water-tight seal. (Recommended minimum panel thickness is 0.125" [3.18 mm].)

After the panel cut-out has been completed and deburred, carefully slide the panel gasket over the rear of the timer body to the back of the bezel. Insert the unit into the panel. As depicted in the drawing, install the two tinnerman nuts and two self-tapping screws onto the mounting clip. To install the mounting clip; hold the mounting clip with both hands so that the top corners rest on the index finger of each hand and the bottom corners rest on the middle finger of each hand. While doing this, place the thumb of each hand over the mounting screws. By pressing on the screws, flex the clip enough to slide it over the back end of the Lynx case until the clip snaps into the groove of the bezel. Tighten the two mounting screws.

Caution: Only minimum pressure is required to seal the panel. Do **NOT** overtighten mounting screws.

APPLICATION FOR LYNX TIMER

CANDY WRAPPING OPERATION

A candy manufacturer has a requirement to automatically shrink wrap their packaged candy. The boxed candy is loaded on a conveyor belt and sent to the automatic shrink wrap machine. The conveyor speed and position is controlled by a PLC. However, an external time adjustment is required to allow for different size boxes to be processed.

Timing accuracy is very important to insure that the shrink wrap is sealed without melting the candy. The Dual Preset Lynx Timer is chosen due to its accuracy and the ability to easily change the presets. Changing of the presets will meet the time requirements for different size packages.

As the package is moved into the shrink wrap machine, the PLC receives a signal that the package is in position. At this time, the PLC sends a signal to close the Run Input switch of the Lynx Timer. It takes 1.5 seconds for the

machine to wrap a package 6" long. At the end of this time, Output 1 of the Lynx Timer signals the PLC to move the package to the shrink oven. As soon as the PLC receives the signal from the Lynx, it opens the Run input switch stopping timer operation while the package is placed in the oven. When the package is in position, the PLC closes the Run Input switch. This restarts the timer from 1.5 seconds. The time required in the oven is 3 seconds, so Preset 2 is set for 4.5. When the timer reaches Preset 2, output 2 signals the PLC to move the package out of the oven. At the end of the cycle, the PLC performs a reset via the Remote Reset terminal. This action resets the timer to zero in preparation for the next package.

DIP Switches

S1	Disable Reset	Switches 2 to 5 set the mode of operation to Mode 1 (Timed Output at preset, Manual Reset to Zero)
S2	Up	
S3	Up	
S4	Up	
S5	Down	
S6	0.01	
S7	Sec	

TBA Connections

Terminal 1 (REM.RST)	PLC Output
Terminal 2 (PGM.DIS)	Key Switch
Terminal 3 (RUN)	PLC Output
Terminal 4 (COMM.)	PLC

TBB Connections

Terminals 1 & 2	Primary Power
Terminals 4 & 5 (Relay 1)	PLC (move package to oven)
Terminals 7 & 8 (Relay 2)	PLC (remove package from oven)
Terminals 3 & 6	Not used

Front Panel Programming

Preset 1	1.50
Preset 2	4.50 (this will give 3 seconds in the oven)
Timed Output	10 seconds

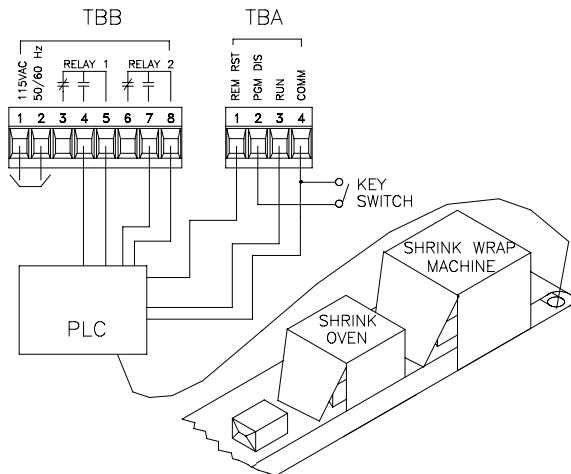

ORDERING INFORMATION

MODEL NO.	DESCRIPTION	PART NUMBERS FOR AVAILABLE SUPPLY VOLTAGES			
		12VDC	24VDC	230VAC	115VAC
LNXT1	Lynx Single Preset Timer	LNXT1020	LNXT1030	LNXT1010	LNXT1000
LNXT2	Lynx Dual Preset Timer	LNXT2020	LNXT2030	LNXT2010	LNXT2000

For more information on Pricing, Enclosures & Panel Mount Kits, refer to the RLC Catalog or contact your local RLC distributor.

TROUBLESHOOTING

For further technical assistance, contact technical support at the appropriate company numbers listed.

LIMITED WARRANTY

The Company warrants the products it manufactures against defects in materials and workmanship for a period limited to one year from the date of shipment, provided the products have been stored, handled, installed, and used under proper conditions. The Company's liability under this limited warranty shall extend only to the repair or replacement of a defective product, at The Company's option. The Company disclaims all liability for any affirmation, promise or representation with respect to the products.

The customer agrees to hold Red Lion Controls harmless from, defend, and indemnify RLC against damages, claims, and expenses arising out of subsequent sales of RLC products or products containing components manufactured by RLC and based upon personal injuries, deaths, property damage, lost profits, and other matters which Buyer, its employees, or sub-contractors are or may be to any extent liable, including without limitation penalties imposed by the Consumer Product Safety Act (P.L. 92-573) and liability imposed upon any person pursuant to the Magnuson-Moss Warranty Act (P.L. 93-637), as now in effect or as amended hereafter.

No warranties expressed or implied are created with respect to The Company's products except those expressly contained herein. The Customer acknowledges the disclaimers and limitations contained herein and relies on no other warranties or affirmations.

Red Lion Controls
20 Willow Springs Circle
York PA 17402
Tel +1 (717) 767-6511
Fax +1 (717) 764-0839

Red Lion Controls BV
Basicweg 11b
NL - 3821 BR Amersfoort
Tel +31 (0) 334 723 225
Fax +31 (0) 334 893 793

Red Lion Controls Asia
31, Kaki Bukit Road 3 #06-02 TechLink
Singapore 417818
Tel +65 6744-6613
Fax +65 6743-3360