

## DA 8 Digital Input / 8 Relay Output Module

### Installation Guide

- Adds I/O capability to the DA70
- Offers complete isolation; inputs, power and Controller
- Inputs independently software selectable for sink or source signals, high or low active states, and high or low frequency signals
- Ideal for data acquisition applications
- Configured using Crimson® software (version 3.1 or later)



FOR USE IN HAZARDOUS LOCATIONS:  
 Class I, Division 2, Groups A, B, C, and D  
 T4



### MODULE PACKAGE CHECKLIST

This product package should contain the items listed below. If any items are missing or damaged, contact Red Lion immediately.

- DIN Rail Mount DA 8DI/8RO Module
- Installation Guide

### GENERAL DESCRIPTION

The DA 8DI/8RO module is designed for use with the DA70 controllers, that can support up to 10 I/O modules simultaneously. This module features 8 Digital Inputs and 8 Relay Outputs that can be used to monitor contact or sensor inputs and actuate relays, solenoids, PLC inputs, etc.

The inputs accept standard DC inputs or contact closures, and are configured for Sink/Source signals via software switches. Additionally, each input has a switch selectable input filter that can be used to prevent contact bounce. Each input may also be software configured as a high-active or low-active input.

The module is available with relay outputs that are capable of switching up to one amp each. For applications requiring large loads to be controlled, several DIN rail mount relays are available.

The modules connect and communicate via proprietary backplane to the DA host device. The DA host device, equipped with serial ports as well as an Ethernet port(s), allows the system to share data with PCs, PLCs, and SCADA systems.

Internal power management circuits allow the module to be replaced while power is applied, which reduces downtime in the event of a module failure. All configuration information is stored locally within the module, as well as in the Host, so replacement modules do not need to be configured.

### DIMENSIONS In Inches (mm)

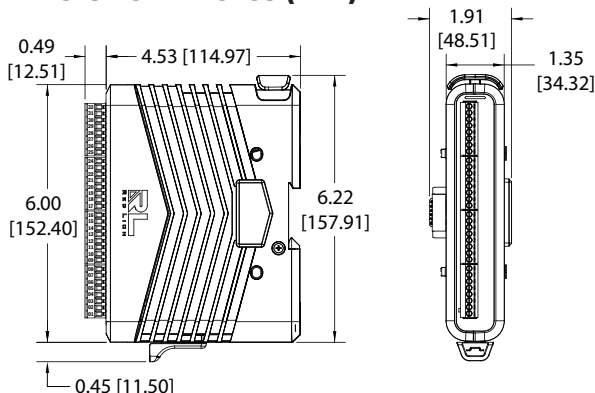

### CONFIGURATION

The DA 8DI/8RO modules are configured with Windows® compatible Crimson® software. The software is an easy to use, graphical interface which provides a means of configuration and commissioning of new systems, as well as routine module re-calibration.

### SAFETY SUMMARY

All safety related regulations, local codes and instructions that appear in this document or on equipment must be observed to ensure personal safety and to prevent damage to either the device or equipment connected to it.

Do not use these products to replace proper safety interlocking. No software-based device (or any other solid-state device) should ever be designed to be responsible for the maintenance of personnel safety or consequential equipment not equipped with safeguards. Red Lion disclaims any responsibility for damages, either direct or consequential, that result from the use of this equipment in a manner not specified.

	<p><b>CAUTION: Risk of Danger</b>                  Read complete instructions prior to installation and operation of the unit.</p> <p><b>ATTENTION : Risque de danger</b>                  Lire les instructions complètes avant l'installation et l'utilisation de l'appareil.</p>
	<p><b>WARNING - EXPLOSION HAZARD - SUBSTITUTION OF COMPONENTS MAY IMPAIR SUITABILITY FOR CLASS I, DIVISION 2</b></p> <p><b>AVERTISSEMENT - DANGER D'EXPLOSION - LE REMPLACEMENT DE COMPOSANTS PEUT NUIRE À L'APTITUDE À LA CLASSE I, DIVISION 2</b></p>
	<p>This equipment is suitable for use in Class I, Division 2, Groups A, B, C, D, or non-hazardous locations only.</p> <p>Cet équipement est adapté à une utilisation dans des endroits de classe I, Division 2, Groupes A, B, C, D, ou dans des endroits non dangereux seulement.</p>

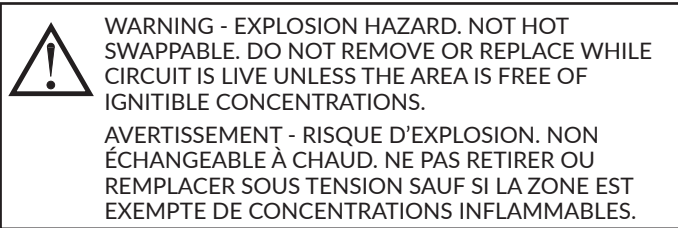

## SPECIFICATIONS

### 1. POWER REQUIREMENTS:

Power is supplied by the DA host controller. Modules may be hot-swapped (replaced while powered up) in non-hazardous locations only.

**Max Power:** 2.0 W

### 2. LEDs:

One LED indicator for each I/O point and a status LED.

### 3. MEMORY:

Non-volatile memory retains all programmable parameters.

### 4. Digital Input: Software selectable for sink or source

Maximum voltage: +30 VDC, reverse polarity protected

Off Voltage: < 1.2 Volts

On Voltage: > 3.8 Volts

Input Impedance: Source Mode 10K ohms; Sink Mode 20K ohms

Input Frequency\*:

Software Filter selection on: 50 Hz

Software Filter selection off: 300 Hz

\* Actual usable frequency limited by communication to external device.

### 5. Form A Relay Output: 4 relays per module

Type: Normally Open

Contact Ratings:

Per Relay: 0.5 Amps @ 30 VDC/30 VAC at 65 °C T<sub>AMB</sub>

2 Amps @ 30 VDC/30 VAC at 60 °C T<sub>AMB</sub>

Life Expectancy: 100,000 cycles at max. load rating.

(Decreasing load, increasing cycle time, and use of surge suppression such as RC snubbers increases life expectancy.)

### 6. ISOLATION LEVEL: 500 Vrms @ 50/60 Hz for 1 minute between the following:

Inputs

Outputs

Host Controller

### 7. COMMUNICATIONS: Provided by the DA70 Controller

### 8. ENVIRONMENTAL CONDITIONS:

Operating Temperature Range: -40 to 75 °C T<sub>AMB</sub>

Storage Temperature Range: -40 to 80 °C T<sub>AMB</sub>

Vibration to IEC 60068-2-6: Operational 5-500 Hz, 2 g

Shock to IEC 60068-2-27: Operational 15 g

Operating and Storage Humidity: 0 to 95% max. RH non-condensing

Altitude: Up to 2000 meters

Installation Category II, Pollution Degree 2 as defined in IEC/EN 60664-1.

### 9. CERTIFICATIONS AND COMPLIANCES:

CE Approved

EN 61326-1 Immunity to Industrial Locations

Emission CISPR 11 Class A

IEC/EN 61010-1

RoHS Compliant

UL Hazardous: File # E317425

Rugged IP30 enclosure

### 10. CONNECTIONS: Removable wire clamp screw terminal blocks

Wire Strip Length: 0.3" (7.5 mm)

Wire Gauge Capacity: 14 to 24 AWG (2.08 to 0.20 mm<sup>2</sup>)

copper wire only

Torque: 2 inch-lbs (0.23 N-m)

### 11. CONSTRUCTION: Polycarbonate enclosure with IP30 rating. For use only in an approved enclosure.

### 12. MOUNTING REQUIREMENTS: Mounts onto standard DIN style top hat (T) profile mounting rails according to EN50022 - 35 x 7.5 mm and 35 x 15 mm.

### 13. WEIGHT: 14.0 oz (397 g)

## EMC INSTALLATION GUIDELINES

Although Red Lion Controls products are designed with a high degree of immunity to Electromagnetic Interference (EMI), proper installation and wiring methods must be followed to ensure compatibility in each application. The type of the electrical noise, source or coupling method into a unit may be different for various installations. Cable length, routing, and shield termination are very important and can mean the difference between a successful or troublesome installation. Listed are some EMI guidelines for a successful installation in an industrial environment.

1. A unit should be mounted in a metal enclosure, which is properly connected to protective earth.
2. Use shielded cables for all Signal and Control inputs. The shield connection should be made as short as possible. The connection point for the shield depends somewhat upon the application. Listed below are the recommended methods of connecting the shield, in order of their effectiveness.
  - a. Connect the shield to earth ground (protective earth) at one end where the unit is mounted.
  - b. Connect the shield to earth ground at both ends of the cable, usually when the noise source frequency is over 1 MHz.
3. Never run Signal or Control cables in the same conduit or raceway with AC power lines, conductors, feeding motors, solenoids, SCR controls, and heaters, etc. The cables should be run through metal conduit that is properly grounded. This is especially useful in applications where cable runs are long

and portable two-way radios are used in close proximity or if the installation is near a commercial radio transmitter. Also, Signal or Control cables within an enclosure should be routed as far away as possible from contactors, control relays, transformers, and other noisy components.

4. Long cable runs are more susceptible to EMI pickup than short cable runs.
5. In extremely high EMI environments, the use of external EMI suppression devices such as Ferrite Suppression Cores for signal and control cables is effective. The following EMI suppression devices (or equivalent) are recommended:
  - Fair-Rite part number 0443167251 (Red Lion #FCOR0000)
  - Line Filters for input power cables:
    - Schaffner # FN2010-1/07 (Red Lion #LFIL0000)
6. To protect relay contacts that control inductive loads and to minimize radiated and conducted noise (EMI), some type of contact protection network is normally installed across the load, the contacts or both. The most effective location is across the load.
  - a. Using a snubber, which is a resistor-capacitor (RC) network or metal oxide varistor (MOV) across an AC inductive load is very effective at reducing EMI and increasing relay contact life.
  - b. If a DC inductive load (such as a DC relay coil) is controlled by a transistor switch, care must be taken not to exceed the breakdown voltage of the transistor when the load is

switched. One of the most effective ways is to place a diode across the inductive load. Most Red Lion products with solid state outputs have internal zener diode protection. However external diode protection at the load is always a good design practice to limit EMI. Although the use of a snubber or varistor could be used.

Red Lion part numbers: Snubber: SNUB0000

Varistor: ILS11500 or ILS23000

7. Care should be taken when connecting input and output devices to the instrument. When a separate input and output common is provided, they should not be mixed. Therefore a sensor common should NOT be connected to an output common. This would cause EMI on the sensitive input common, which could affect the instrument's operation.

Visit <https://www.redlion.net/emi> for more information on EMI guidelines, Safety and CE issues as they relate to Red Lion products.

## HARDWARE INSTALLATION

### Removing Module From Cradle

To remove the module from the cradle, push in the module release button at the top of the cradle and pull the module out of the cradle.

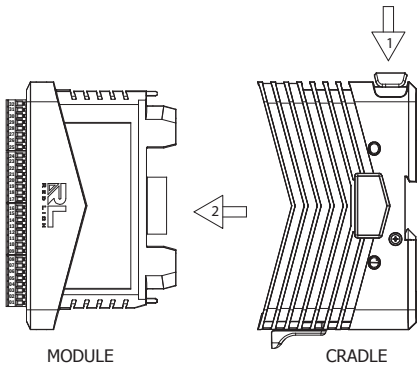

### Attaching the Module/Cradle to the DIN Rail

The DIN rail should be mounted horizontally so that the unit's ventilation holes are vertical in relation to installation orientation. A minimum clearance of 1 inch (25.4 mm) should be maintained above and below the unit to ensure proper thermal regulation.

For hazardous location installation, the unit shall be installed inside a UL Listed Industrial Control Panel or similar type of enclosure that can only be opened with the use of a tool.

The cradle can be installed on the DIN rail with or without the module attached. Ensure the DIN rail lock latch is in the outward most position (unlocked). Hook the top back of the cradle DIN rail clip over the DIN rail. Press the cradle until flush with the rail and push the DIN rail lock latch to the latched (in) position.

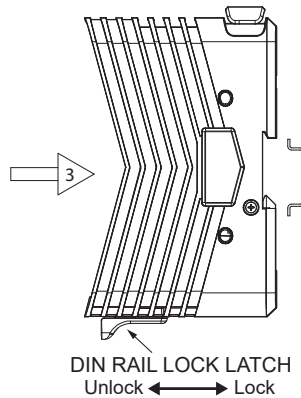

### Installing Module into Cradle

Push module into cradle until you hear an audible click indicating it is properly latched.

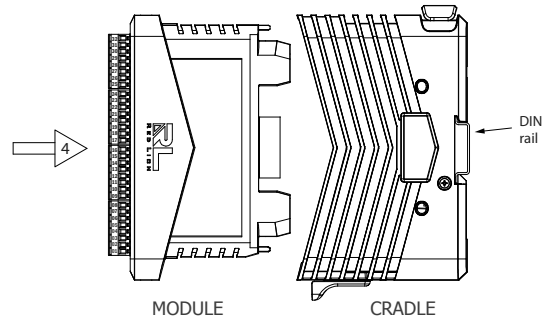

### MODULE HOT SWAPPING

If the area is known to be non-hazardous (free of ignitable concentrations), then a module can be removed and/or installed into a cradle attached to the controller while power is applied. However, it is **NOT** recommended to connect to or remove from the controller, a module/cradle pair or group of modules/cradles, while power is applied. The power should be turned off anytime a cradle or group of cradles (with or without modules) is plugged into or removed from the controller.

### WIRING

All power, input and output (I/O) wiring must be in accordance with Class I, Division 2 wiring methods and in accordance with the authority having jurisdiction.

All conductors should meet voltage and current ratings for each terminal. When wiring the module, use the numbers on the label to identify the position number with the proper function. Strip the wire, leaving approximately 0.3" (7.5 mm) of bare wire exposed. Insert the wire into the terminal, and tighten.

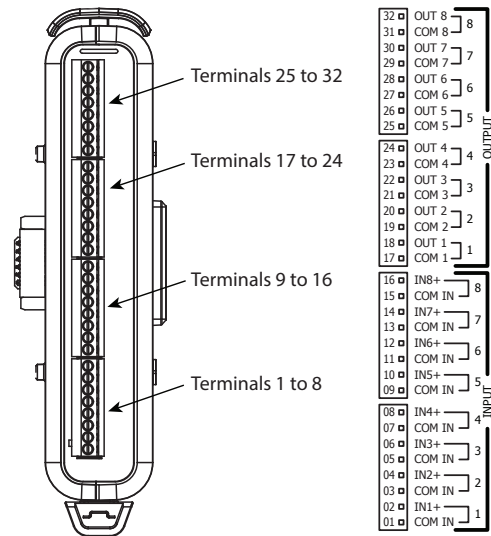

**CAUTION:** Only UL listed wiring with temperature ratings greater than 90 °C permitted for Class I, Division 2 installations.

**ATTENTION:** Seul le câblage homologué UL avec des températures nominales supérieures à 90°C est autorisé pour les installations de classe I, Division 2.

### I/O Wiring

The DA 8DI/8RO offers 8 discrete inputs and 8 Form A relay outputs. The discrete inputs and outputs operate on the same voltage that powers the unit. Pluggable screw block terminals are provided for the I/O wiring connections. Refer to the diagrams below on how to make your I/O connections.

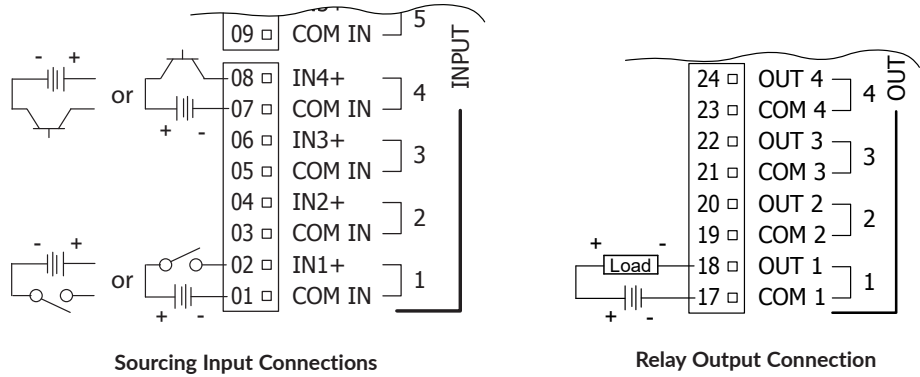

### STATUS LED

LED COLOR(S)	LED STATE	MEANING
Blue	3 quick flashes	Module is booting.
Green	Solid	Module is configured and running.
Green/Off	Flashing	Module is running but is not configured.
Green/Purple	Flashing	Module is performing calibration.
Red/Green	Flashing	Module is running but communication with the controller is inactive. If status persists, contact technical support.
Red/Off	Flashing	An internal error has occurred. If status persists, contact technical support.
Yellow/Off	Flashing	Module position is unassigned. If status persists, contact technical support.
Off	Solid	Module application is not running or the module is not powered. If status persists, contact technical support.

### FIRMWARE UPGRADE

The module's firmware is stored in flash memory so that software/ hardware conflicts are avoided, and so features can be added in the future.

During a download, Crimson compares its own library of firmware files with those stored in the module. If they do not match, Crimson will download the necessary firmware.

### RED LION CONTROLS TECHNICAL SUPPORT

If for any reason you have trouble operating, connecting, or simply have questions concerning your new product, contact Red Lion's technical support.

Support: [support.redlion.net](http://support.redlion.net)  
 Website: [www.redlion.net](http://www.redlion.net)  
 Inside US: +1 (877) 432-9908  
 Outside US: +1 (717) 767-6511

Red Lion Controls, Inc.  
 35 Willow Springs Circle York, PA 17406

### ORDERING INFORMATION

DESCRIPTION	PART NUMBER
DA 8 Channel DI/ 8 Channel RO Module	DA M0010 DI0RO 0000

Spaces in listed part numbers are shown to improve readability, do not include when searching for or ordering these parts.

### COPYRIGHT

©2020-2022 Red Lion Controls, Inc. All rights reserved. Red Lion and the Red Lion logo are trademarks of Red Lion Controls, Inc. All other company and product names are trademarks of their respective owners.

### LIMITED WARRANTY

(a) Red Lion Controls Inc. (the "Company") warrants that all Products shall be free from defects in material and workmanship under normal use for the period of time provided in "Statement of Warranty Periods" (available at [www.redlion.net](http://www.redlion.net)) current at the time of shipment of the Products (the "Warranty Period"). **EXCEPT FOR THE ABOVE-STATED WARRANTY, COMPANY MAKES NO WARRANTY WHATSOEVER WITH RESPECT TO THE PRODUCTS, INCLUDING ANY (A) WARRANTY OF MERCHANTABILITY; (B) WARRANTY OF FITNESS FOR A PARTICULAR PURPOSE; OR (C) WARRANTY AGAINST INFRINGEMENT OF INTELLECTUAL PROPERTY RIGHTS OF A THIRD PARTY; WHETHER EXPRESS OR IMPLIED BY LAW, COURSE OF DEALING, COURSE OF PERFORMANCE, USAGE OF TRADE OR OTHERWISE.** Customer shall be responsible for determining that a Product is suitable for Customer's use and that such use complies with any applicable local, state or federal law.

(b) The Company shall not be liable for a breach of the warranty set forth in paragraph (a) if (i) the defect is a result of Customer's failure to store, install, commission or maintain the Product according to specifications; (ii) Customer alters or repairs such Product without the prior written consent of Company.

(c) Subject to paragraph (b), with respect to any such Product during the Warranty Period, Company shall, in its sole discretion, either (i) repair or replace the Product; or (ii) credit or refund the price of Product provided that, if Company so requests, Customer shall, at Company's expense, return such Product to Company.

(d) **THE REMEDIES SET FORTH IN PARAGRAPH (c) SHALL BE THE CUSTOMER'S SOLE AND EXCLUSIVE REMEDY AND COMPANY'S ENTIRE LIABILITY FOR ANY BREACH OF THE LIMITED WARRANTY SET FORTH IN PARAGRAPH (a). BY INSTALLING THIS PRODUCT, YOU AGREE TO THE TERMS OF THIS WARRANTY, AS WELL AS ALL OTHER DISCLAIMERS AND WARRANTIES IN THIS DOCUMENT.**