

DA J1939 Sled Installation Guide

- Configured using Crimson® software (version 3.2 or later)
- Digitally isolated J1939 port capable of communicating with any J1939 protocol device
- Powered and configured from DA host device
- Built-in switch selectable termination resistor
- Industrial rated for harsh environments
- Wide operating temperature range
- Simplified deployment architecture
- Field installable

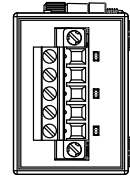
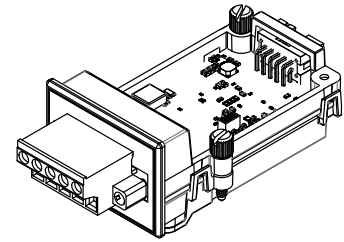

II 3 G Ex ec IIC T4 Gc
 DEMKO 20 ATEX 2268X
 IECEx UL 20.0007X
 UL22UKEX2576X

For use with DA50 and DA70 series covered in DEMKO 20 ATEX 2268X and IECEx UL 20.0007X certificates



FOR USE IN HAZARDOUS LOCATIONS:
 Class I, Division 2, Groups A, B, C, and D
 T4

IND.CONT. EQ.
 E317425

PACKAGE CHECKLIST

This product package should contain the items listed below. If any items are missing or damaged, contact Red Lion immediately.

- DA J1939 Sled
- Installation Guide

SAFETY SUMMARY

All safety related regulations, local codes and instructions that appear in this document or on equipment must be observed to ensure personal safety and to prevent damage to either the device or equipment connected to it.

Do not use these products to replace proper safety interlocking. No software-based device (or any other solid-state device) should ever be designed to be responsible for the maintenance of personnel safety or consequential equipment not equipped with safeguards. Red Lion disclaims any responsibility for damages, either direct or consequential, that result from the use of this equipment in a manner not consistent with these specifications.

	CAUTION: Risk of Danger Read complete instructions prior to installation and operation of the unit.
	ATTENTION : Risque de danger Lire les instructions complètes avant l'installation et l'utilisation de l'appareil.

ORDERING INFORMATION

PART NUMBER	DESCRIPTION
DAS00PN8J16IS000	DA Series, J1939 Protocol Interface Sled

SPECIFICATIONS

- POWER REQUIREMENTS:** Power is supplied by the DA host controller.
 Max Power: 1 W

2. COMMUNICATIONS:

J1939 Protocol Port: The J1939 protocol port has format and baud rates that are software programmable up to 1 M baud and is digitally isolated. 100 Ohm, 1 W termination is provided through a switch. This port may be configured for various J1939 protocols.

Isolation from DA J1939 Communication ports to DA host controller: 1000 VDC for 1 minute.

3. ENVIRONMENTAL CONDITIONS:

Operating Temperature Range: -40 to 75 °C T_{AMB}

Storage Temperature Range: -40 to 80 °C T_{AMB}

Vibration to IEC 60068-2-6: Operational 5-500 Hz, 2 g

Shock to IEC 60068-2-27: Operational 15 g

Operating and Storage Humidity: 0 to 95% max. RH non-condensing

Altitude: Up to 2000 meters

4. CERTIFICATIONS AND COMPLIANCES:

CE Approved

EN 61326-1 Immunity to Industrial Locations

Emission CISPR 11 Class A

IEC/EN 61010-1

RoHS Compliant

ATEX Approved

II 3 G Ex ec IIC T4 Gc

DEMKO 20 ATEX 2268X

IECEX Approved

IECEX UL 20.0007X

UKEX Approved

UL22UKEX2576X

UL Hazardous: File # E317425

5. CONNECTIONS:

Removable wire clamp screw terminal block

Wire Strip Length: 0.3" (7.5 mm)

Wire Gauge: 28-14 AWG (0.32 mm - 1.63 mm²) copper wire only

Torque: 1.95-2.21 inch-lbs (0.22-0.25 N-m)

6. INSTALLATION REQUIREMENTS:

Sled must be installed inside the unit case with the hardware provided. See

"Installing the J1939 Sled" for more details.

7. WEIGHT:

2.5 oz (71 g)

INSTALLING THE J1939 SLED



CAUTION: Follow standard ESD precautionary procedures.
ATTENTION: Suivez les procédures de précaution standard de décharge électrostatique.



WARNING - Disconnect all power to the unit before installing or removing sleds.
AVERTISSEMENT - Débranchez l'alimentation électrique de l'appareil avant d'installer ou de retirer les tiroirs.

DA50 INSTALLATION

1. Prior to installing the Sled for your DA50 application, ensure that the unit is not receiving power.
2. Disconnect and remove your DA50 from the DIN rail.
3. Remove the DA50 unit's front cap by squeezing the sides and pulling.
4. Slide out the sled holder.
5. Install the sled into the sled holder and hand tighten the captive fasteners, or use a screwdriver.
6. Re-install the sled holder containing the sled into the Converter. Make sure it is fully seated.
7. Replace the front cap.

DA70 INSTALLATION

1. Prior to installing the Sled(s) for your DA70 Controller application, ensure that the Controller is not receiving power.
2. Remove the carriage from the Controller case by releasing the two retaining latches and pulling straight out from Controller
3. Remove blank panel from the carriage slot of the target sled installation location.
4. Install sled by aligning the two sled mounting hole fasteners, with the controller mounting posts. Be sure locating holes on bottom side of sled align with the locating pins on the carriage, and the sled sits flush against the carriage.
5. Hand tighten the sled captive fasteners, or use a screwdriver if necessary.
6. Repeat the above steps for any additional sleds.
7. Carefully align the carriage with the Controller base and press carriage into the controller.





CAUTION: Failure to properly align the carriage can result in damage to the Sled connector pins.
ATTENTION: Si le tiroir n'est pas correctement aligné, les broches du connecteur du tiroir risquent d'être endommagées.

8. Close the retaining latches to ensure the carriage is fully seated into the Controller case.

CONFIGURING THE DA J1939 SLED

DA50A or DA70A CONFIGURATION

The J1939 Sled is configured using the web GUI or Crimson 3.2 (or later) software. Find additional information in the Crimson 3.2 User Manual.

J1939 PORT PROTOCOLS

The DA J1939 sled has one J1939 protocol port. This port may be configured for various J1939 protocols.

TERMINATION RESISTOR

An onboard termination resistor is switch selectable. The termination resistor is rated for 100Ω at 1W. If a different termination resistance is desired, slide the switch for no termination resistor. At this point you will be required to connect your own termination resistor between positions 2 and 4 of the five position connector.

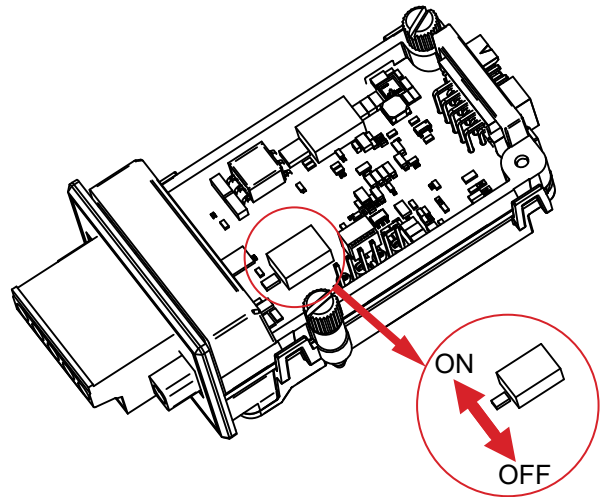

WIRING

All wiring must be in accordance with Class I, Division 2 wiring methods and in accordance with the authority having jurisdiction.

All conductors should meet voltage and current ratings for each terminal. When wiring the module, use the numbers on the label to identify the position number with the proper function. Strip the wire, leaving approximately 0.3" (7.5 mm) of bare wire exposed. Insert the wire into the terminal, and tighten.

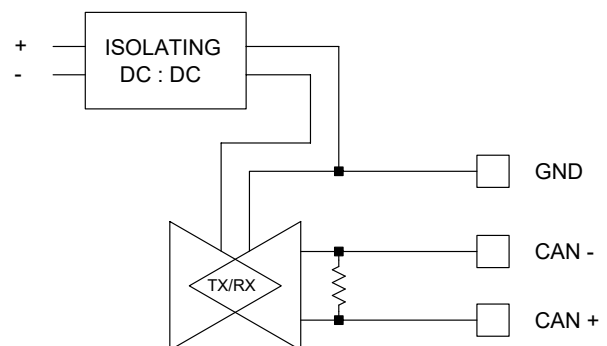

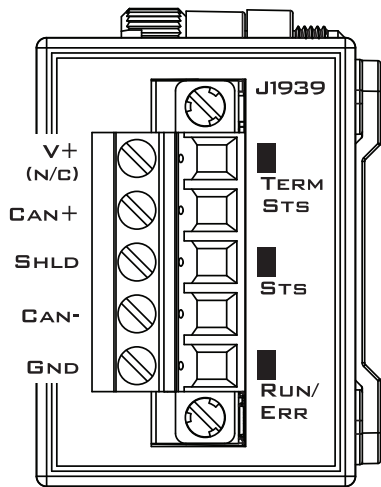

WARNING - EXPLOSION HAZARD - DO NOT CONNECT OR DISCONNECT CABLES WHILE POWER IS APPLIED UNLESS AREA IS KNOWN TO BE NON-HAZARDOUS.
AVERTISSEMENT - RISQUE D'EXPLOSION - NE PAS BRANCHER OU DÉBRANCHER LES CÂBLES PENDANT QUE L'ALIMENTATION EST APPLIQUÉE À MOINS QUE LA ZONE SOIT CONNAISSANTE POUR ÊTRE NON DANGEREUSE.

V+ (N/C) [OPTIONAL 24 VDC]

Position 5 of the pluggable connector is provided for optional 24 VDC connections. This position is available only to tie 24 VDC wires together. The DA J1939 sled neither provides 24 VDC power nor uses 24 VDC power through this connection. The V+ position is not connected to any circuitry internal to the DA J1939 sled or DA host device.

CAN+

Position 4 of the pluggable connector provides the CAN+ bus line (active high). This terminal is isolated from the DA host device.

SHLD (N/C) [OPTIONAL CAN SHIELD]

Position 3 of the pluggable connector is provided for optional shield connections. This position is available to tie shield wires to earth ground. The SHLD position is connected through a series RC network to CHASSIS as noted in specification J1939-11. The SHLD connection is internally tied to the DA host device.

CAN-

Position 2 of the pluggable connector provides the CAN- bus line (active low). This terminal is isolated from the DA host device.

GND

Position 1 of the pluggable connector provides a ground connection. This terminal is isolated from the DA host device.

SLED LEDs

TERM STS - On board Termination Resistor Status LED

This LED indicates whether the onboard termination resistor is connected or disconnected.

COLOR	STATUS
Off	Termination resistor is not connected.
Green	Termination resistor is connected.

STS – SLED Status LED

The Status LED is a bi-color LED that provides information regarding the state of the sled's communication connection with the controller. The status is described below.

COLOR	STATUS
Off	No power to the unit
Green	Sled is powered and application is started.
Green Flashing	Sled has lost communication with the Host.
Orange	Firmware is being updated.

RUN/ERR LED

COLOR	STATUS
Green	J1939 sled established communication with other J1939 protocol devices (RUN) and is communicating normally
Red	J1939 sled failed to establish communications with other J1939 protocol devices (ERROR).

RED LION CONTROLS TECHNICAL SUPPORT

If for any reason you have trouble operating, connecting, or simply have questions concerning your new unit, contact Red Lion's technical support.

Support: support.redlion.net

Website: www.redlion.net

Inside US: +1 (877) 432-9908

Outside US: +1 (717) 767-6511

Red Lion Controls, Inc.

35 Willow Springs Circle York, PA 17406

COPYRIGHT

©2020-22 Red Lion Controls, Inc. All rights reserved. Red Lion and the Red Lion logo are trademarks of Red Lion Controls, Inc. All other company and product names are trademarks of their respective owners.

LIMITED WARRANTY

(a) Red Lion Controls Inc. (the "Company") warrants that all Products shall be free from defects in material and workmanship under normal use for the period of time provided in "Statement of Warranty Periods" (available at www.redlion.net) current at the time of shipment of the Products (the "Warranty Period"). **EXCEPT FOR THE ABOVE-STATED WARRANTY, COMPANY MAKES NO WARRANTY WHATSOEVER WITH RESPECT TO THE PRODUCTS, INCLUDING ANY (A) WARRANTY OF MERCHANTABILITY; (B) WARRANTY OF FITNESS FOR A PARTICULAR PURPOSE; OR (C) WARRANTY AGAINST INFRINGEMENT OF INTELLECTUAL PROPERTY RIGHTS OF A THIRD PARTY; WHETHER EXPRESS OR IMPLIED BY LAW, COURSE OF DEALING, COURSE OF PERFORMANCE, USAGE OF TRADE OR OTHERWISE.** Customer shall be responsible for determining that a Product is suitable for Customer's use and that such use complies with any applicable local, state or federal law.

(b) The Company shall not be liable for a breach of the warranty set forth in paragraph (a) if (i) the defect is a result of Customer's failure to store, install, commission or maintain the Product according to specifications; (ii) Customer alters or repairs such Product without the prior written consent of Company.

(c) Subject to paragraph (b), with respect to any such Product during the Warranty Period, Company shall, in its sole discretion, either (i) repair or replace the Product; or (ii) credit or refund the price of Product provided that, if Company so requests, Customer shall, at Company's expense, return such Product to Company.

(d) **THE REMEDIES SET FORTH IN PARAGRAPH (c) SHALL BE THE CUSTOMER'S SOLE AND EXCLUSIVE REMEDY AND COMPANY'S ENTIRE LIABILITY FOR ANY BREACH OF THE LIMITED WARRANTY SET FORTH IN PARAGRAPH (a).**

BY INSTALLING THIS PRODUCT, YOU AGREE TO THE TERMS OF THIS WARRANTY, AS WELL AS ALL OTHER DISCLAIMERS AND WARRANTIES IN THIS DOCUMENT.