

DA PID Single Loop and Dual Loop Modules Installation Guide

- Dedicated single and dual PID modules for the DA70
- Auto addressing minimizes configuration time
- Fully isolated design provides reliable operation
- PID control with reduced overshoot
- Universal inputs accept TC, RTD, 0-10 V and 0/4-20 mA signals
- On demand auto-tuning of PID settings
- DC analog output (1PID only)
- Heater current input (optional, 2PID only) ensures detection of heater circuit failure
- Configured using Crimson® software (version 3.1 or later)



II 3 G Ex ec IIC T4 Gc
 DEMKO 20 ATEX 2268X
 IECEx UL 20.0007X
 UL22UKEX2576X

For Part Numbers: DAM00PDP1SA00000,
 DAM00PDP2S000000, and DAM00PDP2SM00000 Only

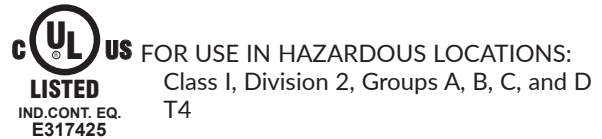

MODULE PACKAGE CHECKLIST

This product package should contain the items listed below. If any items are missing or damaged, contact Red Lion immediately.

- DIN rail mount DA PID Module
- Installation Guide

GENERAL DESCRIPTION

The DA PID modules are full featured PID controllers designed for use with the DA70 controllers. The 1PID is a single loop controller, while the 2PID is a dual loop controller. The design of the system provides a true modular PID control platform for multi-zone control applications. The modules can accept a wide range of thermocouple, RTD, 0-10 V, 0/4-20 mA signals. With multiple discrete outputs, plus an analog output (1PID only), the DA PID modules can perform virtually any combination of time-proportioning or linear control for heat, cool, or heat/cool applications. The discrete outputs may also be assigned to one of seven internal soft alarms. The 1PID's linear output can be assigned to transmit virtually any internal variable.

The modules connect and communicate via proprietary

DIMENSIONS In inches (mm)

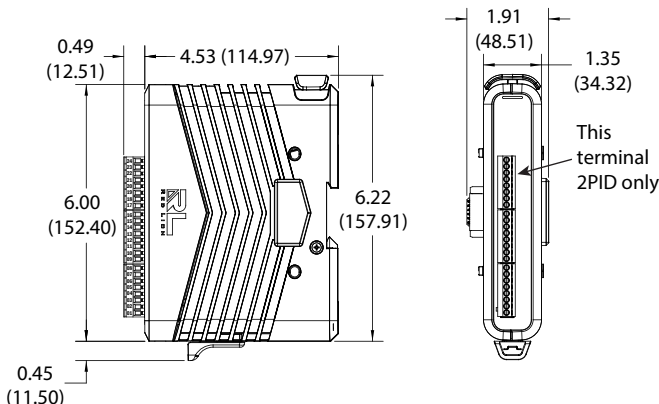

backplane to the DA host device. The DA host device, equipped with serial ports as well as an Ethernet port(s), allows the system to share data with PCs, PLCs, and SCADA systems.

Internal power management circuits allow the module to be replaced while power is applied, which reduces downtime in the event of a relay failure. All configuration information is stored locally within the module, as well as in the Host, so replacement modules do not need to be configured.

The modules can operate in On/Off, P, PI, or PID control mode, and use an on-demand Auto-Tune that establishes the tuning constants. The PID constants may be fine-tuned through the serial or Ethernet interface. The modules employ a unique overshoot suppression feature, which allows the quickest response without excessive overshoot. The modules can also be operated in manual mode, providing the operator with direct control of the output.

CONFIGURATION

The DA PID modules are configured with Windows® compatible Crimson® software. The software is an easy to use, graphical interface which provides a means of configuration and commissioning of new systems, as well as routine re-calibration of modules.

ALARMS

Each loop within the modules has seven internal "soft" alarms, which can be assigned to trigger any output. This includes four process alarms, two heater current, and one input fault alarm.

ANALOG OUTPUT OPTION (1PID ONLY)

The DC Analog Output (10 V or 20 mA) can be independently configured and scaled for control or re-transmission purposes.

HEATER CURRENT MONITOR OPTION (2PID ONLY)

The optional Heater Current Monitor input is useful for early warning of heater degradation, or heater circuit failure. The input

connects to a current transformer with an output of 100 mA AC to ensure that proper heater current is present when the control output is on, and that little or no current is present when the output is off. This provides immediate warning of a circuit short or open, instead of waiting for a high or low temperature shutdown alarm.

SAFETY SUMMARY

All safety related regulations, local codes and instructions that appear in this document or on equipment must be observed to ensure personal safety and to prevent damage to either the device or equipment connected to it.

Do not use these products to replace proper safety interlocking. No software-based device (or any other solid-state device) should ever be designed to be responsible for the maintenance of personnel safety or consequential equipment not equipped with safeguards. Red Lion disclaims any responsibility for damages, either direct or consequential, that result from the use of this equipment in a manner not specified.

	CAUTION: Risk of Danger Read complete instructions prior to installation and operation of the unit.
	ATTENTION : Risque de danger Lire les instructions complètes avant l'installation et l'utilisation de l'appareil.

	WARNING - EXPLOSION HAZARD - SUBSTITUTION OF COMPONENTS MAY IMPAIR SUITABILITY FOR CLASS I, DIVISION 2
	AVERTISSEMENT - DANGER D'EXPLOSION - LE REMPLACEMENT DE COMPOSANTS PEUT NUIRE À L'APTITUDE À LA CLASSE I, DIVISION 2

	This equipment is suitable for use in Class I, Division 2, Groups A, B, C, D, or non-hazardous locations only.
	Cet équipement est adapté à une utilisation dans des endroits de classe I, Division 2, Groupes A, B, C, D, ou dans des endroits non dangereux seulement.

	WARNING - EXPLOSION HAZARD. NOT HOT SWAPPABLE. DO NOT REMOVE OR REPLACE WHILE CIRCUIT IS LIVE UNLESS THE AREA IS FREE OF IGNITIBLE CONCENTRATIONS.
	AVERTISSEMENT - RISQUE D'EXPLOSION. NON ÉCHANGEABLE À CHAUD. NE PAS RETIRER OU REMPLACER SOUS TENSION SAUF SI LA ZONE EST EXEMPTÉ DE CONCENTRATIONS INFLAMMABLES.

SPECIFICATIONS

- POWER:** Power is supplied by the DA host device. Modules may be hot-swapped (replaced while powered up) in non-hazardous locations only.
1PID Max Power: 3.3 W
2PID Max Power: 2.7 W
- LEDs*:**
 STS – RGB Status LED shows module condition.
 OP1, OP2, OP3, OP4 - Indicate status of outputs 1, 2, 3, and 4
 ALM, or ALM1 and ALM2 - Alarm LEDs are lit during an internal alarm condition
 * Default configuration.
- MEMORY:** Non-volatile memory retains all programmable parameters.
- INPUTS:**
GENERAL:
 Sample Time: 50 msec (20 Hz)
 Common Mode Rejection: >110 dB, 50/60 Hz

Normal Mode Rejection: >50 dB, 50/60 Hz
 Temperature Coefficient: 0.01%/°C
 Step Response Time: 100 msec typ., 200 msec max
THERMOCOUPLE INPUTS:
 Types: T, E, J, K, R, S, B, N, C
 Input Impedance: 20 M ohm
 Lead Resistance Effect: 0.25 μV/ohm
 Cold Junction Compensation: Less than ±1 °C typical (±1.5 °C max) over -40 to 75 °C T_{AMB}
 Resolution: 0.1°

TYPE	MEASUREMENT RANGE	WIRE COLOR	
		ANSI	BS 1843
T	-200 to +400 °C -328 to +752 °F	(+) Blue (-) Red	(+) White (-) Blue
E	-200 to +730 °C -328 to +1346 °F	(+) Violet (-) Red	(+) Brown (-) Blue
J	-200 to +760 °C -328 to +1400 °F	(+) White (-) Red	(+) Yellow (-) Blue
K	-200 to +1350 °C -328 to +2462 °F	(+) Yellow (-) Red	(+) Brown (-) Blue
R	0 to +1768 °C +32 to +3214 °F	No Standard	(+) White (-) Blue
S	0 to +1768 °C +32 to +3214 °F	No Standard	(+) White (-) Blue
B	+149 to +1820 °C +300 to +3308 °F	No Standard	No Standard
N	-200 to +1300 °C -328 to +2372 °F	(+) Orange (-) Red	(+) Orange (-) Blue
C W5/W6	0 to +2315 °C +32 to +4199 °F	No Standard	No Standard
mV	0 mV to 50 mV	N/A	N/A

RTD INPUTS:

Type: 2 or 3 wire
 Excitation: 150 μA
 Lead Resistance: 15 ohms Max
 Resolution: 1 or 0.1°

TYPE	INPUT TYPE	RANGE
385	100 ohm platinum, Alpha = .00385	-200 to +600°C -328 to +1100°F
392	100 ohm platinum, Alpha = .003919	-200 to +600°C -328 to +1100°F
672	120 ohm nickel, Alpha = .00672	-80 to +215°C -112 to +419°F

PROCESS INPUT:

INPUT RANGE	ACCURACY	IMPEDANCE	MAX CONTINUOUS OVERLOAD	RESOLUTION
10 V	0.1% span	1 M Ohm	50 V	16 bit
20 mA	0.1% span	10 Ohm	100 mA	16 bit

- PROBE BREAK RESPONSE:** Upscale drive, Input Fault Alarm bit set high, ALx LED illuminates.
- TEMPERATURE INDICATION ACCURACY:** ± (0.3% of span, +1 °C). Includes NIST conformity, cold junction effect, A/D conversion errors, temperature coefficient and linearization conformity at 23 °C after 20 minute warm up.
- ISOLATION LEVEL: 500 Vrms @ 50/60 Hz for 1 minute between the following:**
 OP1
 OP2
 OP3
 OP4
 Linear Output (1PID only)
 Signal Input 1 and HCM (2PID only)
 Signal Input 2 and HCM (2PID only)
 Power Supply Input

8. COMMUNICATIONS: Provided by the DA host device

9. A/D CONVERTER: 16 bit resolution

10. DISCRETE OUTPUTS:

1PID: Outputs 1 and 2 available as Solid State NFET or Form A relay. Output 3 is Solid State NFET or Form C relay.

2PID: Outputs 1, 2 and 4 available as Solid State NFET or Form A relay. Output 3 is Solid State NFET or Form C relay.

Solid State Output:

Type: Switched DC, N Channel open drain MOSFET

Current Rating: 1 A max

VDS ON: 0.3 V @ 1 A

VDS MAX: 30 VDC

Offstate Leakage Current: 0.5 mA max

Form A Relay Output:

Type: N.O.

Contact Ratings:

Per Relay: 2 Amps @ 30 VDC/30 VAC at 55 °C T_{AMB}

3 Amps @ 30 VDC/30 VAC at 50 °C T_{AMB}

Life Expectancy: 200,000 cycles at maximum load rating.

(Decreasing load, increasing cycle time, and use of surge suppression such as RC snubbers increases life expectancy.)

Form C Relay Output:

Type: SPDT

Contact Ratings:

Per Relay: 1 Amp @ 30 VDC/30 VAC at 55 °C T_{AMB}

2 Amps @ 30 VDC/30 VAC at 50 °C T_{AMB}

Life Expectancy: 100,000 cycles at maximum load rating.

(Decreasing load, increasing cycle time, and use of surge suppression such as RC snubbers increases life expectancy.)

11. CONTROL MODES:

Control: On/Off, P, PI, or PID

Output: Time proportioning or linear (1PID only)

Cycle Time: Programmable from 0.0 to 60.0 sec

Auto-Tune: When selected, sets proportional band, integral time, derivative time values, and output dampening time

Probe Break Action: Programmable response

Sensor Fail Response: Upscale

12. ALARMS:

Modes:

Manual

Absolute High Acting

Absolute Low Acting

Deviation High Acting

Deviation Low Acting

Inside Band Acting

Outside Band Acting

Reset Action: Programmable; automatic or latched

Standby Mode: Programmable; enable or disable

Hysteresis: Programmable

Sensor Fail Response: Upscale

13. ANALOG DC OUTPUT (1PID only):

Selectable/programmable for 0-10 VDC, 0-20 mA, or 4-20 mA

Resolution:

Voltage: 500 μV

Current: 1 μA

Accuracy:

0.1% of full scale (18 to 28 °C T_{AMB})

0.2% of full scale (-40 to 75 °C T_{AMB})

Update Time: 0.0 to 60.0 sec

Compliance (for current output only): 500 ohm max.

Minimum load (voltage output only): 10 K ohm min.

Outputs are software selectable for either 10 V or 20 mA. The output range may be field calibrated to yield approximate 10% overrange and a small underrange (negative) signal.

14. HEATER CURRENT MONITOR INPUT (optional):

Type: 300 V max, 50 A max. Single phase, full wave monitoring of load currents

Input: 100 mA max. input for use with external current transformers

Input Resistance: 5 ohms

Accuracy: ±3.0% full scale, 5 to 100% of range

Frequency: 50 to 400 Hz

Minimum output on time for break alarm: 350 msec

Note: To ensure isolation to SELV circuits, use a UL Listed current transformer.

15. ENVIRONMENTAL CONDITIONS:

Operating Temperature Range:

Modules with Relays: -40 to 70 °C T_{AMB}

Modules with Solid-State Outputs: -40 to 75 °C T_{AMB}

Storage Temperature Range: -40 to +85 °C T_{AMB}

Shock to IEC 68-2-27: Operational 40 g (15 g, modules w/ relays)

Operating and Storage Humidity: 0 to 85% max. Relative humidity, non-condensing.

Altitude: Up to 2000 meters

16. CERTIFICATIONS AND COMPLIANCES:

CE Approved

EN 61326-1 Immunity to Industrial Locations

Emission CISPR 11 Class A

IEC/EN 61010-1

RoHS Compliant

ATEX Approved (DAM00PDP1SA00000, DAM00PDP2S000000, and DAM00PDP2SM00000 Only)

Ⓜ II 3 G Ex ec IIC T4 Gc

DEMKO 20 ATEX 2268X

IECEX Approved (DAM00PDP1SA00000, DAM00PDP2S000000, and DAM00PDP2SM00000 Only)

IECEX UL 20.0007X

UKEX Approved (DAM00PDP1SA00000, DAM00PDP2S000000, and DAM00PDP2SM00000 Only)

UL22UKEX2576X

UL Hazardous: File #E317425

Rugged IP30 enclosure

17. CONSTRUCTION: Metal and plastic enclosure with IP30 rating. For use only in approved enclosure.

18. CONNECTIONS: Removable wire clamp screw terminal blocks

Wire Strip Length: 0.3" (7.5 mm)

Wire Gauge Capacity: 14 to 24 AWG (2.08 to 0.20 mm²) copper wire only

Torque: 2 inch-lbs (0.23 N-m)

19. MOUNTING: Mounts onto standard DIN style top hat (T) profile mounting rails according to EN50022 – 35 x 7.5 mm and 35 x 15 mm.

20. WEIGHT: 11.1 oz (315 g)

Block Diagram

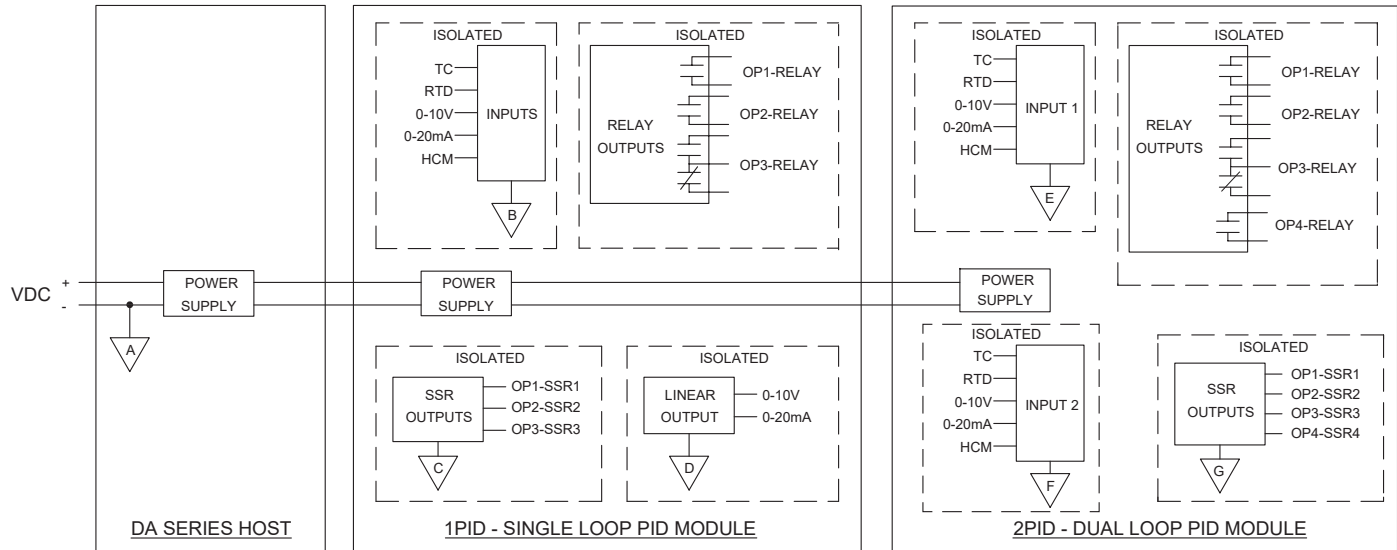

EMC INSTALLATION GUIDELINES

Although Red Lion Controls products are designed with a high degree of immunity to Electromagnetic Interference (EMI), proper installation and wiring methods must be followed to ensure compatibility in each application. The type of the electrical noise, source or coupling method into a unit may be different for various installations. Cable length, routing, and shield termination are very important and can mean the difference between a successful or troublesome installation. Listed are some EMI guidelines for a successful installation in an industrial environment.

1. A unit should be mounted in a metal enclosure, which is properly connected to protective earth.
2. Use shielded cables for all Signal and Control inputs. The shield connection should be made as short as possible. The connection point for the shield depends somewhat upon the application. Listed below are the recommended methods of connecting the shield, in order of their effectiveness.
 - a. Connect the shield to earth ground (protective earth) at one end where the unit is mounted.
 - b. Connect the shield to earth ground at both ends of the cable, usually when the noise source frequency is over 1 MHz.
3. Never run Signal or Control cables in the same conduit or raceway with AC power lines, conductors, feeding motors, solenoids, SCR controls, and heaters, etc. The cables should be run through metal conduit that is properly grounded. This is especially useful in applications where cable runs are long and portable two-way radios are used in close proximity or if the installation is near a commercial radio transmitter. Also, Signal or Control cables within an enclosure should be routed as far away as possible from contactors, control relays, transformers, and other noisy components.
4. Long cable runs are more susceptible to EMI pickup than short cable runs.
5. In extremely high EMI environments, the use of external EMI suppression devices such as Ferrite Suppression Cores for signal and control cables is effective. The following EMI

suppression devices (or equivalent) are recommended:

Fair-Rite part number 0443167251 (Red Lion Controls #FCOR000)

Line Filters for input power cables:

Schaffner # FN2010-1/07 (Red Lion Controls #LFIL0000)

6. To protect relay contacts that control inductive loads and to minimize radiated and conducted noise (EMI), some type of contact protection network is normally installed across the load, the contacts or both. The most effective location is across the load.
 - a. Using a snubber, which is a resistor-capacitor (RC) network or metal oxide varistor (MOV) across an AC inductive load is very effective at reducing EMI and increasing relay contact life.
 - b. If a DC inductive load (such as a DC relay coil) is controlled by a transistor switch, care must be taken not to exceed the breakdown voltage of the transistor when the load is switched. One of the most effective ways is to place a diode across the inductive load. Most Red Lion products with solid state outputs have internal zener diode protection. However external diode protection at the load is always a good design practice to limit EMI. Although the use of a snubber or varistor could be used.
Red Lion part numbers: Snubber: SNUB0000
Varistor: ILS11500 or ILS23000
7. Care should be taken when connecting input and output devices to the instrument. When a separate input and output common is provided, they should not be mixed. Therefore a sensor common should NOT be connected to an output common. This would cause EMI on the sensitive input common, which could affect the instrument's operation.

Visit <https://www.redlion.net/emi> for more information on EMI guidelines, Safety and CE issues as they relate to Red Lion products.

HARDWARE INSTALLATION

Removing Module From Cradle

To remove the module from the cradle, push in the module release button at the top of the cradle and pull the module out of the cradle.

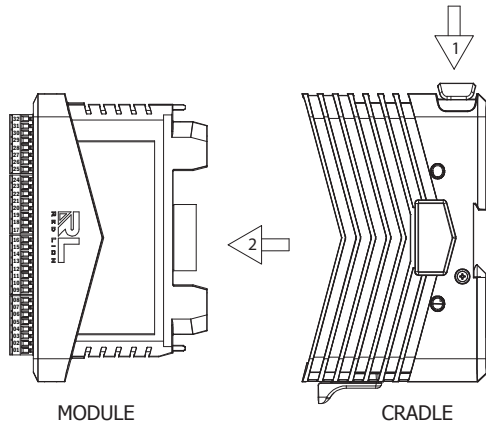

Installing Module into Cradle

Push module into cradle until you hear an audible click indicating it is properly latched.

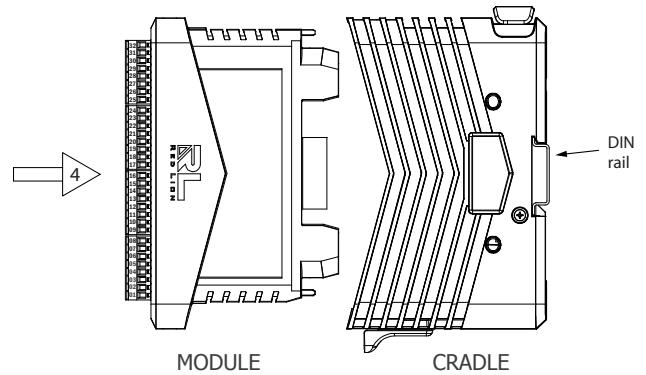

Attaching the Module/Cradle to the DIN Rail

The DIN rail should be mounted horizontally so that the unit's ventilation holes are vertical in relation to installation orientation. A minimum clearance of 1 inch (25.4 mm) should be maintained above and below the unit to ensure proper thermal regulation.

The cradle can be installed on the DIN rail with or without the module attached. Ensure the DIN rail lock latch is in the outward most position (unlocked). Hook the top back of the cradle DIN rail clip over the DIN rail. Press the cradle until flush with the rail and push the DIN rail lock latch to the latched (in) position.

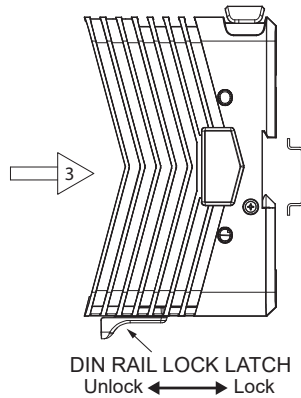

For hazardous location installation, the following shall be taken into consideration:

- The equipment shall only be used in an area of at least pollution degree 2, as defined in EN/IEC 60664-1.
- The equipment shall be installed in an enclosure that provides a minimum ingress protection of IP54 in accordance with EN/IEC 60079-0. The enclosure shall be accessible only with the use of a tool.
- Transient protection shall be provided that is set at a level not exceeding 140% of the peak rated voltage value at the supply terminals to the equipment.

WIRING

WIRING CONNECTIONS

All power, input and output (I/O) wiring must be in accordance with Class I, Division 2 wiring methods and in accordance with the authority having jurisdiction.

All conductors should meet voltage and current ratings for each terminal. When wiring the module, use the numbers on the label to identify the position number with the proper function. Strip the wire, leaving approximately 0.3" (7.5 mm) of bare wire exposed. Insert the wire into the terminal, and tighten.

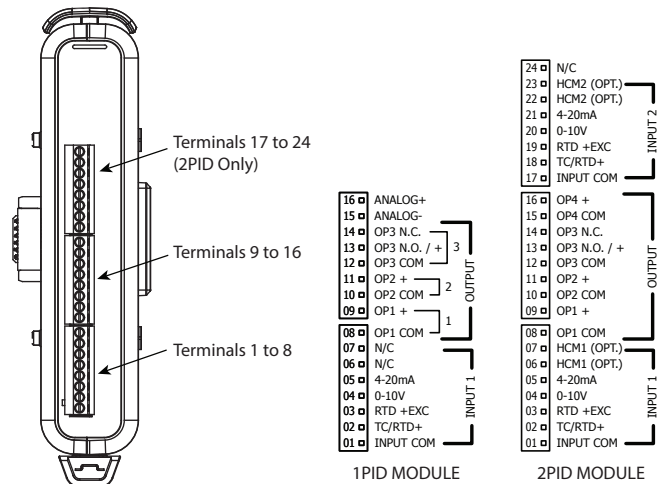

CAUTION: Only UL listed wiring with temperature ratings greater than 90 °C permitted for Class I, Division 2, Zone 2 and ATEX, IECEx and UKEX installations.

ATTENTION: Seul le câblage homologué UL avec des températures nominales supérieures à 90°C est autorisé pour les installations de classe I, Division 2, zone 2 et ATEX, IECEx et UKEX.

INPUT WIRING

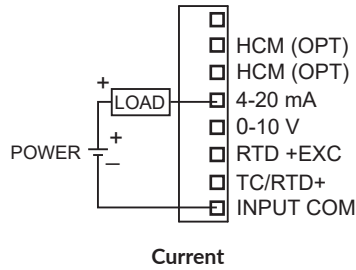
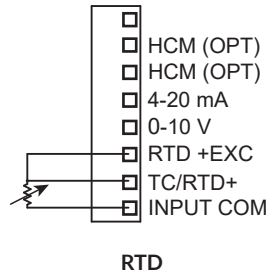
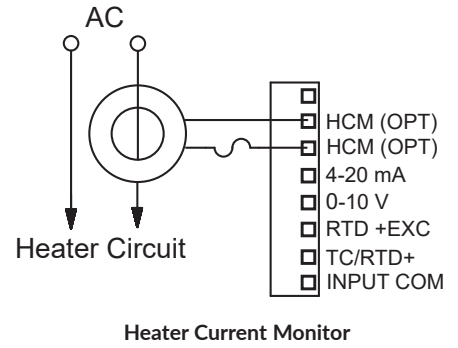
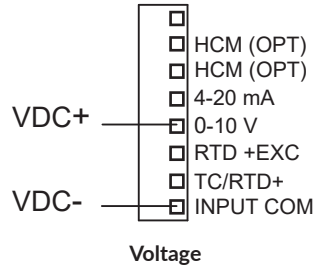
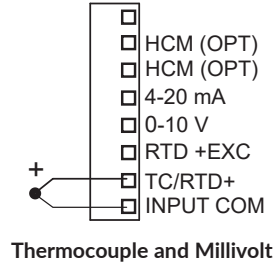

OUTPUT WIRING

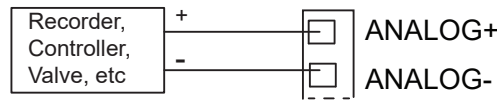
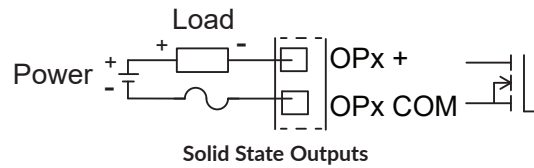
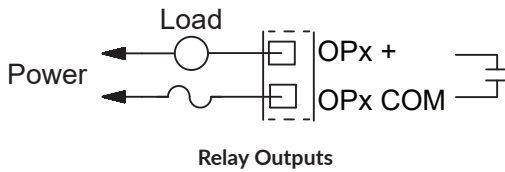

LEDs

STATUS LED

The red/green/blue Status LED is located at the top of the module and provides information regarding the state of the module. This includes indication of the various stages of the start-up routine (power-up), as well as any errors that may occur.

LED COLOR(S)	MEANING
Flashing Blue	Module is booting.
Flashing Green	Module is switching to configuration.
Green	Module is performing normally.
Flashing Green/Purple	Module is performing auto calibration.
Flashing Blue/Yellow	Module is being flash upgraded by Crimson.
Flashing Red	Error: general error with module.
Flashing Red/Green	Error: module is controlling properly, but has lost communication with the Host.
Flashing Yellow	Error: no bus frequency.
Flashing Red/Green/Blue	Error: module is running the Factory Programming Console.

OP1, OP2, OP3, OP4* – Output Status LED

The green OP1, OP2, OP3, and OP4* LEDs are factory configured to indicate the status of the outputs. The LEDs turn on when the output is active.

These LEDs may be remapped to various other module properties.

*2PID only

ALM or ALM1, ALM2 – Alarm LED

The red Alarm LEDs indicate the presence of an alarm. Whenever one of the seven alarms is active, the LED turns on.

FIRMWARE UPGRADE

The module's firmware is stored in flash memory so that software/ hardware conflicts are avoided, and so features can be added in the future.

During a download, Crimson compares its own library of firmware files with those stored in the module. If they do not match, Crimson will download the necessary firmware.

RED LION CONTROLS TECHNICAL SUPPORT

If for any reason you have trouble operating, connecting, or simply have questions concerning your new product, contact Red Lion's technical support.

Support: support.redlion.net

Website: www.redlion.net

Inside US: +1 (877) 432-9908

Outside US: +1 (717) 767-6511

Red Lion Controls, Inc.

35 Willow Springs Circle York, PA 17406

ORDERING INFORMATION

TYPE	DESCRIPTION	PART NUMBER
Input Modules	DA70 Series Module, Single PID, Relay and Analog Outputs ¹	DAM00PDP1RA00000
	DA70 Series Module, Single PID, SSR and Analog Outputs	DAM00PDP1SA00000
	DA70 Series Module, Dual PID, Relay Outputs ¹	DAM00PDP2R000000
	DA70 Series Module, Dual PID, SSR Outputs	DAM00PDP2S000000
	DA70 Series Module, Dual PID, SSR and Heater Current Monitor	DAM00PDP2SM00000
Accessories	50 Amp Current Transformer (For Heater Current Models), UL Recognized component, Instrument Transformers, Inc. Part #2SFT500-0.	CT005001

A listing of the entire DA70 family of products and accessories can be found at www.redlion.net.

¹ Module is not suitable for use in hazardous locations.

COPYRIGHT

©2020-2022 Red Lion Controls, Inc. All rights reserved. Red Lion and the Red Lion logo are trademarks of Red Lion Controls, Inc. All other company and product names are trademarks of their respective owners.

LIMITED WARRANTY

(a) Red Lion Controls Inc. (the "Company") warrants that all Products shall be free from defects in material and workmanship under normal use for the period of time provided in "Statement of Warranty Periods" (available at www.redlion.net) current at the time of shipment of the Products (the "Warranty Period"). **EXCEPT FOR THE ABOVE-STATED WARRANTY, COMPANY MAKES NO WARRANTY WHATSOEVER WITH RESPECT TO THE PRODUCTS, INCLUDING ANY (A) WARRANTY OF MERCHANTABILITY; (B) WARRANTY OF FITNESS FOR A PARTICULAR PURPOSE; OR (C) WARRANTY AGAINST INFRINGEMENT OF INTELLECTUAL PROPERTY RIGHTS OF A THIRD PARTY; WHETHER EXPRESS OR IMPLIED BY LAW, COURSE OF DEALING, COURSE OF PERFORMANCE, USAGE OF TRADE OR OTHERWISE.** Customer shall be responsible for determining that a Product is suitable for Customer's use and that such use complies with any applicable local, state or federal law.

(b) The Company shall not be liable for a breach of the warranty set forth in paragraph (a) if (i) the defect is a result of Customer's failure to store, install, commission or maintain the Product according to specifications; (ii) Customer alters or repairs such Product without the prior written consent of Company.

(c) Subject to paragraph (b), with respect to any such Product during the Warranty Period, Company shall, in its sole discretion, either (i) repair or replace the Product; or (ii) credit or refund the price of Product provided that, if Company so requests, Customer shall, at Company's expense, return such Product to Company.

(d) **THE REMEDIES SET FORTH IN PARAGRAPH (c) SHALL BE THE CUSTOMER'S SOLE AND EXCLUSIVE REMEDY AND COMPANY'S ENTIRE LIABILITY FOR ANY BREACH OF THE LIMITED WARRANTY SET FORTH IN PARAGRAPH (a).**

BY INSTALLING THIS PRODUCT, YOU AGREE TO THE TERMS OF THIS WARRANTY, AS WELL AS ALL OTHER DISCLAIMERS AND WARRANTIES IN THIS DOCUMENT.