

DA50N

Secure Edge Networking Gateway



FLEXEDGE™ Intelligent Edge Automation Platform

RED LION'S DA50N MODULAR NETWORKING GATEWAY PROVIDES SECURE EDGE CONNECTIVITY FOR INDUSTRIAL APPLICATIONS.

In a market of ever-changing requirements and increasing rates of innovation, the need for equipment that can quickly adapt to meet these needs is critical. The modular design of the DA50N ensures communications capabilities can easily be added or modified as application needs change, future-proofing installations.

The FlexEdge Secure Edge Networking Gateway can be managed locally through direct device connection or remotely via SixView Manager® software, our flexible remote management software package designed to help increase productivity and reduce costs for organizations. With a web-based console and customized dashboard, users are able to remotely access, configure and manage critical device information from a central location.

APPLICATIONS

- ▲ Oil & Gas
- ▲ Factory Automation
- ▲ Water/Wastewater
- ▲ Maritime
- ▲ Alternative Energy
- ▲ Industrial Internet of Things (IIoT)

PRODUCT HIGHLIGHTS

- ▲ Intuitive LED Status Ring
- ▲ Secure Network Routing and Communication
- ▲ LAN-to-LAN or LAN-to-WAN Connectivity
- ▲ Intrusion Protection Through Stateful Firewall
- ▲ NAT Support For 1-to-1 and 1-to-Many Translations
- ▲ 25 VPN Connections for Secure Remote Access
- ▲ Rugged Industrial Design in a Compact Package

FEATURES & BENEFITS

MODULAR DESIGN

- ▲ Easily Add Wireless Communications to Any Application

POWERFUL ADVANCED NETWORKING FEATURES

- ▲ Remote TCP/IP Based Capabilities
- ▲ Integrated Switching and Routing
- ▲ DHCP Server/DHCP Relay
- ▲ Serial-to-IP
- ▲ SNMP V1, V2, V3
- ▲ IPSEC and SSL VPN Tunnels
- ▲ Port Forwarding
- ▲ Stateful Firewall
- ▲ Access Control List (ACL)

DESIGNED FOR INDUSTRIAL ENVIRONMENTS, CERTIFIED FOR EASE OF MIND

- ▲ -40 To 75 °C Operating Temperature
- ▲ UL Class 1, Division 2 and ATEX/IECEX Certifications

DA50N Secure Edge Networking Gateway

POWER INPUT

Input Voltage: 12-24 VDC +/-15%

Must use a Class 2 circuit according to National Electrical Code (NEC), NFPA-70 or Canadian Electrical Code (CEC), Part I, C22.1 or a Limited Power Supply (LPS) according to IEC 60950-1 or Limited energy circuit according to IEC 61010-1

INPUT VOLTAGE	12 V	24 V
Typ. Power DA50N Controller only	2.5 W	2.6 W
Max Power DA50N Controller only	3.0 W	3.1 W
Max Power DA50N Controller, with Sled	5.6 W	5.7 W

Wire Strip Length: 0.3" (7.5 mm)

Wire Gauge Capacity: 12 to 24 AWG (3.31 to 0.20 mm²) copper wire only

COMMUNICATION PROPERTIES

Ethernet Interface:

Two (2) 10/100 BASE-T(X) RJ45 ports (1500 Vrms Network Isolation)

Serial Interface: Two Serial Ports with Individual Port Isolation

One (1) RS-232 Serial RJ12 115200 Bps

One (1) RS-485/RS-422 Serial RJ45 115200 Bps

USB Device Port:

One (1) Isolated USB Type B Port Complies with USB Specification 2.0 (Full Speed)

MEMORY

Removable Media:

MicroSD Slot Accepts Class 5 Or Better Card Up to 256 GB capacity.

Industrial Grade MicroSD Card Suggested

On-Board User Memory:

1 GB of Non-volatile Flash Memory

NETWORKING CAPABILITIES

Tunneling:

IPsec and SSL

IP:

NAT, port forwarding, dynamic DNS, DHCP Stateful inspection firewall, IP transparency

Routing Protocols:

OSPF, BGP, RIP, VRRP Encapsulation Protocols

Serial Capabilities:

Serial-to-IP, Out of Band Management

CERTIFICATIONS & COMPLIANCES

CE Approved

EN 61326-1 Immunity to Industrial Locations

Emission CISPR 11 Class A

IEC/EN 61010-1

RoHS Compliant

ATEX Approved

II 3 G Ex ec IIC T4 Gc

DEMKO 20 ATEX 2268X

IECEx Approved

IECEx UL 20.0007X

UL Listed: File #E317425

Rugged IP30 enclosure

ENVIRONMENTAL

Operating Temperature Range: -40 to 75 °C

Storage Temperature Range: -40 to 85 °C

Vibration to IEC 60068-2-6: Operational 5-500 Hz, 2 g

Shock to IEC 60068-2-27: Operational 15 g

Operating and Storage Humidity: 0 to 85% max. RH noncondensing

Altitude: Up to 2000 meters

Installation Category II, pollution degree 2 as defined in IEC/EN 60664-1

MECHANICAL

Polycarbonate

Case Dimensions:

Height: 6.86" (17.4 cm)

Width: 2.03" (5.2 cm)

Depth: 5.11" (13.0 cm)

Weight: 13 oz (404.3 g)

Mounting: DIN Rail

Battery: Lithium Coin Cell

WARRANTY

3 years on design and manufacturing defects

Specifications are subject to change. Visit www.redlion.net for more information

▲ DA50N Secure Edge Networking Gateway

DIMENSIONS In inches (mm)

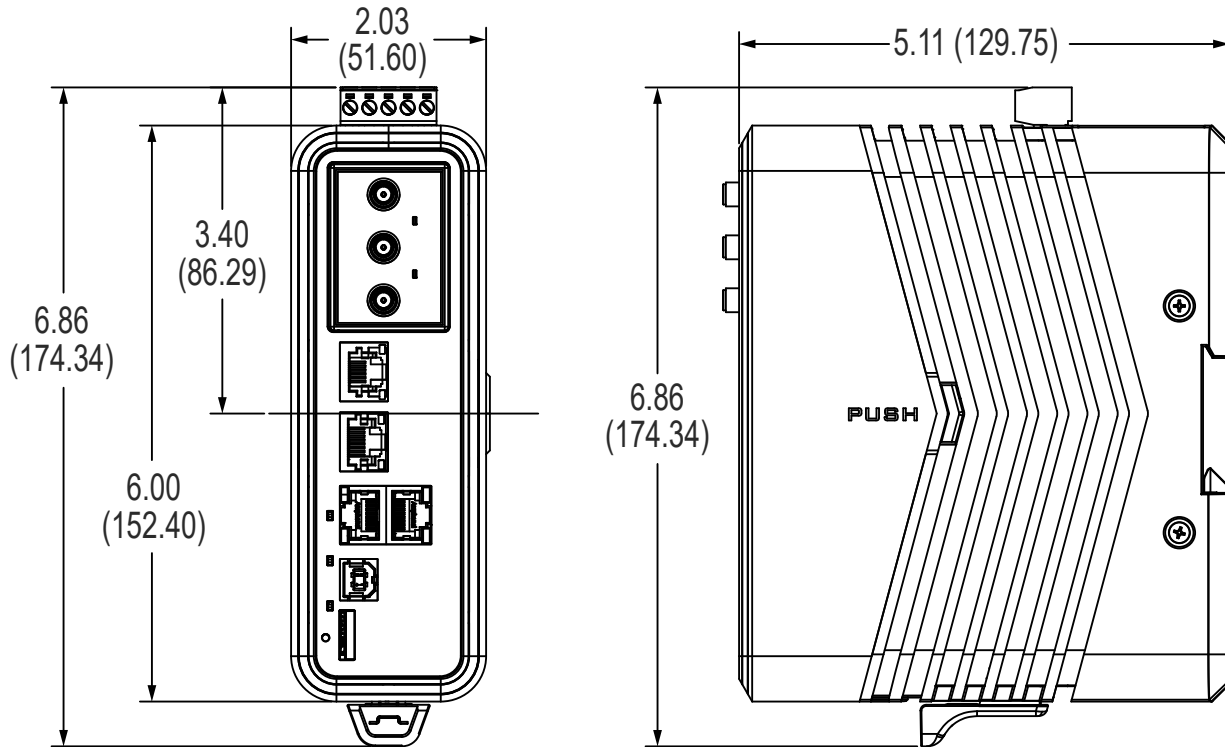

ORDERING GUIDE

Type	Part Number	Description
Controller	DA50N-0B-NN-0000-000	Secure Edge Networking Gateway
Sled	DA-S00-CL9C4S-AM-000	4G LTE (Cat. 4) Cellular Sled for North America (AT&T, Others)
Sled	DA-S00-CL9C4S-VZ-000	4G LTE (Cat. 4) Cellular Sled for North America (Verizon)
Sled	DA-S00-CL9C4S-EU-000	4G LTE (Cat. 4) Cellular Sled for EU, SE Asia, and Asia Pacific
Sled	DA-S00-WF10N0-AM-000	802.11 b/g/n Wi-Fi Sled
Sled	DA-S00-PN40U4-00-000	Single USB 2.0 Host Port Sled

*Dashes in listed model numbers added to improve readability, and are not included in orderable part numbers
See software manual for details on sled operation



www.redlion.net
[contact us](#)

© 2024 Red Lion Controls, Inc. All Rights Reserved. The terms Red Lion, the Red Lion logo and FlexEdge are registered trademarks of Red Lion Controls. All other marks are the property of their respective owners.

LD1334A 05 2024