

MODEL GRAC0001 - Graphite[®] Edge Controller With Plug-In I/O Module and Protocol Conversion Capability

Installation Guide

- Rugged controller with built-in control engine
- Protocol conversion feature converts 13 protocols simultaneously
- Over 300 built-in drivers allows easy data mapping to PLCs, PCs, and SCADA systems
- Built-in web server allows remote view or control from any internet-connected PC or smart phone
- Syncs data logs to FTP servers and Microsoft SQL Server[®]
- Configured using Crimson[®] 3.0, 3.1, or 3.2 software with Crimson Control
- 3 fully isolated serial communication ports (1 RS232 and 2 RS422/485)
- 2 10 Base T/100 Base-TX Ethernet connections can connect to an unlimited number of devices via ten protocols simultaneously
- Integrated Graphite rack expansion port. Add up to 4 GEXRACK2 3 port expansion racks
- Cast aluminum case construction supports DIN rail and panel mount



FOR USE IN HAZARDOUS LOCATIONS:
 Class I, Division 2, Groups A, B, C, and D
 T4



II 3 G Ex ic nA IIC T4 Gc
 -40°C ≤ T_{AMB} ≤ 70°C
 DEMKO 14 ATEX 1387X
 IECEx UL 15.0035X
 UL23UKEX2879X

GENERAL DESCRIPTION

The Graphite[®] Edge Controller is designed to remotely connect, monitor and control equipment in process applications. At the core of the product is Crimson[®] 3.x featuring an embedded IEC61131 control engine, that can be configured via Ladder, Function Block, Structured Text, and Instruction List. Additionally, the Graphite Edge Controller is optimized for multi-vendor environments with powerful protocol conversion, built-in data logging and a virtual operator interface for remotely viewing equipment and processes. The Edge Controller can be expanded to meet almost any application requirement through the use of plug-in digital and analog I/O modules that leverage the Graphite Expansion Racks. The integrated rack port supports 4 GEXRACK2 bases (12 modules). An additional 12 modules can be added using the USB host port (GEXRACK1, 3 GEXRACK2).

Red Lion's industry leading protocol library offers access to over 300 drivers including PLCs, drives, cameras, bar code readers and many other devices providing easy data mapping to PLCs, PCs, and SCADA Systems. In addition, the Edge Controller can convert over 13 protocols simultaneously, seamlessly connecting and communicating with disparate devices. Graphite Edge Controllers offer numerous communication ports including high-speed RS-232/485 and 10/100Base-T(X) Ethernet ports. Additionally, the Edge Controller features built-in USB host ports for fast downloads of configuration files and access to trending

and data logging information. Eliminate the need for external protocol converters and use an Edge Controller to connect and control to all your devices.

The Graphite Edge Controller can be programmed with Red Lion's Crimson 3.x software using a simple drag and drop interface to configure data tags, virtual displays, protocol conversion and data logging in minutes. Embedded in Crimson 3 software platform is the IEC 61131 control engine, Crimson Control which can be written in 4 programming languages including Ladder, Function Block, Structured Text, and Instruction List. The controller comes with Crimson Control functionality enabled, without the need for additional equipment or modules.

Red Lion's Edge Controller is housed in an all-aluminum housing, which provides reliable operation that can withstand even the most demanding environments. The result is an industrially-hardened solution that connects, monitors, and controls disparate equipment in multi-vendor applications.

CONTENTS OF PACKAGE

- Graphite Edge Controller
- Terminal block for connecting power
- (1) Module port cover
- Downstream port cover
- User Bulletin

SAFETY SUMMARY

All safety related regulations, local codes as well as instructions that appear in this document or on equipment must be observed to ensure personal safety and to prevent damage to either the device or equipment connected to it.

Do not use these products to replace proper safety interlocking. No software-based device (or any other solid-state device) should ever be designed to be responsible for the maintenance of personnel safety or consequential equipment not equipped with safeguards. Red Lion disclaims any responsibility for damages, either direct or consequential, that result from the use of this equipment in a manner not consistent with these specifications.



CAUTION: Risk of Danger.
Read complete instructions prior to installation and operation of the unit.



WARNING - EXPLOSION HAZARD - Do not disconnect equipment unless power has been switched off or area is known to be non-hazardous.



WARNING - EXPLOSION HAZARD - Substitution of components may impair suitability for Class I, Division 2

SPECIFICATIONS

1. POWER REQUIREMENTS:

Must use a Class 2 circuit according to National Electrical Code (NEC), NFPA-70 or Canadian Electrical Code (CEC), Part I, C22.1 or a Limited Power Supply (LPS) according to IEC 60950-1 or Limited-energy circuit according to IEC 61010-1.

Power connection via removable three position terminal block.
Supply Voltage: 10-30 VDC

Input Voltage	GRAC0001 POWER RATINGS (WATTS)			
	10 V	12 V	24 V	30 V
Typical Power GRAC0001 only:	4 W	4 W	5 W	5 W
Maximum Power GRAC0001 only:	9 W	9 W	10 W	10 W
Available Power for Modules:	55 W			
Max Power GRAC0001 With Module(s):	64 W	64 W	67 W	67 W

2. **BATTERY:** Lithium coin cell. Typical lifetime of 6 years, nominal.

3. MEMORY:

On Board User Memory: 256 Mbyte of non-volatile Flash memory.

Memory Card: SD slot accepts standard capacity cards.

4. COMMUNICATION CAPABILITIES:

USB Port: Adheres to USB specification 2.0 (high speed, full speed) only using Type B connection.



WARNING - Do not connect or disconnect cables while power is applied unless area is known to be non-hazardous.

USB Host Ports: Comply with Universal Serial Bus Specification Rev 2.0. Support data transfers at (high speed, full speed). Hardware over current protected (0.5 A max per port).

Serial Ports: Ports are individually isolated. Format and Baud Rates for each port are individually software programmable up to 115,200 baud.

PGM Port: RS232 port via RJ12.

COMMS Ports: RS422/485 ports via RJ45

DH485 TXEN: Transmit enable; open collector, $V_{OH} = 15\text{ VDC}$, $V_{OL} = 0.5\text{ V}$ @ 25 mA max.

Port to Port Isolation: 500 Vrms for 1 minute. Signal Isolation: 50 V.

Ethernet Ports: 10 BASE-T / 100 BASE-TX

RJ45 jack is wired as a NIC (Network Interface Card).

Isolation from Ethernet network to GRAC0001: 1500 Vrms

5. ENVIRONMENTAL CONDITIONS:

Operating Temperature Range: -40 to 70 °C T_{AMB} , or lowest range among equipment used in your Graphite system.

Consult the user manual or www.redlion.net/OpTemp for further details.

Storage Temperature Range: -40 to 85 °C T_{AMB}

Panel Mount Vibration to IEC 68-2-6: Operational 5-500 Hz, 4 g
Panel Mount Shock to IEC 68-2-27: Operational 40 g (10 g, modules w/relays)

DIN Rail Mount Vibration to IEC 68-2-6: Operational 5-500 Hz, 2 g

DIN Rail Mount Shock to IEC 68-2-27: Operational 15 g (10 g, modules w/relays)

Requires DIN Rail type: DIN 1010, DIN 1065, or DIN 3065.

Operating and Storage Humidity: 0 to 85% max. RH non-condensing

Altitude: Up to 2000 meters

Installation Category II, Pollution Degree 2 as defined in IEC/EN 60664-1.

6. CERTIFICATIONS AND COMPLIANCES:

CE Approved

EN 61326-1 Immunity to Industrial Locations

Emission CISPR 11 Class A

IEC/EN 61010-1

RoHS Compliant

ATEX/UKEX Approved

II 3 G Ex nA IIC T4 Gc

DEMKO 14 ATEX 1387X

EN 60079-0, -11, -15 -31

UL23UKEX2879X

IECEx Approved

Ex nA IIC T4 Gc

IECEx UL 15.0035X

IEC 60079-0, -11, -15 -31

UL Listed: File #E302106

UL Hazardous: File #E317425

India PESO Approved

A/P/HQ/MH/104/7441 (P549599)

ABS Type Approval for Shipboard Applications

7. CONNECTIONS:

High compression cage-clamp terminal block

Wire Strip Length: 0.3" (7.5 mm)

Wire Gauge Capacity: One 14 AWG (1.63 mm) solid,

two 18 AWG (1.02 mm) or four 20 AWG (0.81 mm)

Torque: 4.43-5.31 inch-lbs (0.5-0.6 N-m)

8. CONSTRUCTION:

Cast aluminum.

9. WEIGHT:

2 lb 4.2 oz. (1.03 Kg)

DIMENSIONS In inches [mm]

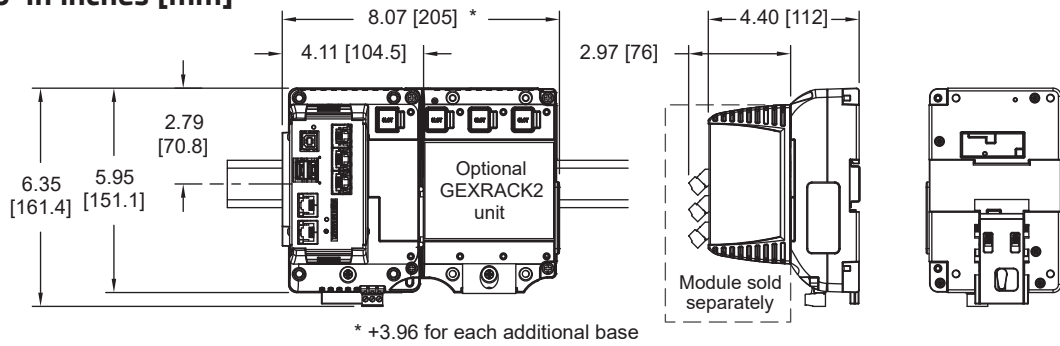

GRAPHITE EDGE CONTROLLER INSTALLATION

PANEL MOUNTING INSTRUCTIONS

The Controller can be mounted on a DIN rail for normal environments, or bolted to a panel for high vibration environments. Refer to the diagram for the panel mount hole spacing.

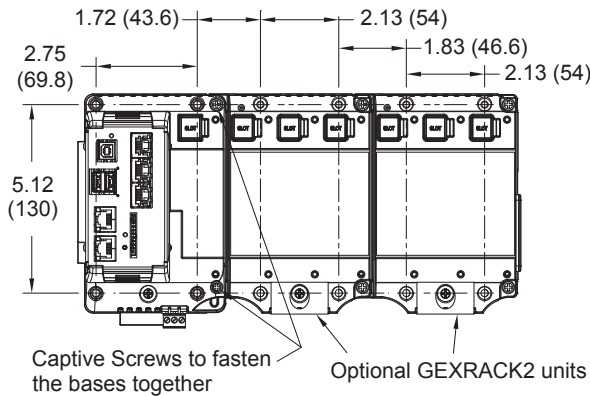

DIN RAIL MOUNT AND CAM OPERATION

DIN rail mounting is only recommended in low vibration environments. Refer to the Specifications section for details.

1. Using a screwdriver, push in and fully rotate the Cam counter-clockwise to push the DIN clip downward against spring pressure locking it open
2. Place the controller on the DIN rail
3. Using a screwdriver, push in and rotate the Cam 90 degrees clockwise to release the DIN clip to engage the DIN rail
4. Rotate the Cam an additional 90 degrees clockwise to lock the DIN clip in the closed position.

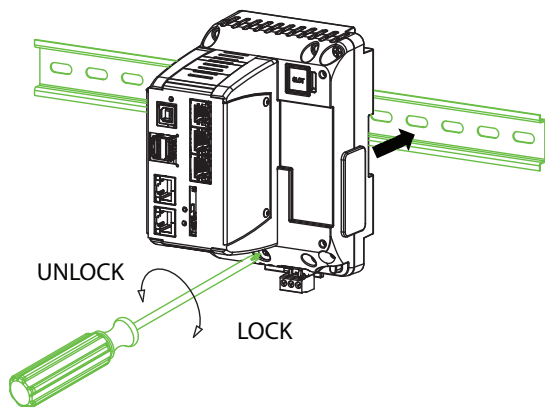

For hazardous location installation the following shall be taken into consideration:

- When used in a Zone 2 environment, the device shall be panel mounted in at least Zone 2 ATEX/IECEX/UKEX-Certified tool accessible enclosure with a minimum ingress protection rating of at least IP54 as defined in IEC/EN 60529.
- The equipment shall only be used in an environment of not more than Pollution Degree 2, as defined in IEC/EN 60664-1.
- Must be wired using Division 2 wiring methods as specified in article 501-4(b), 502-4(b), and 503-3(b) of the National Electric Code, NFPA 70 for installation within the United States, or as specified in section 19-152 of Canadian Electrical Code for installation in Canada.

CONNECTING TO EARTH GROUND

The third pin of the power connector of the Edge Controller is chassis ground for the unit. Your unit should be connected to earth ground.

The chassis ground is not connected to signal common of the unit. Maintaining isolation between earth ground and signal common is not required to operate your unit. But, other equipment connected to this unit may require isolation between signal common and earth ground. *To maintain isolation between signal common and earth ground care must be taken when connections are made to the unit.* For example, a power supply with isolation between its signal common and earth ground must be used. Also, plugging in a USB cable may connect signal common and earth ground.¹

¹ USB's shield may be connected to earth ground at the host. USB's shield in turn may also be connected to signal common.

POWER SUPPLY REQUIREMENTS

The Graphite Edge Controller requires a 10-30 VDC power supply. Your unit may draw considerably less than the maximum rated power depending upon the features being used, and the applied voltage. As additional features are used your unit will draw increasing amounts of power. Items that could cause increases in current are modules, additional on-board communications, SD card, and other features programmed through Crimson software.

Note: Modules connected via a GEXRACK1 to the Edge Controller are powered by the GEXRACK1 and not the Edge Controller

To ensure you do not exceed the capacity of your Graphite host power supply, calculate the total power consumption required for all of your planned modules. Each module's maximum power consumption is listed in the Specifications of their Product Bulletin. The total power available for modules is listed in the specifications of the Graphite host.

In any case, it is very important that the power supply is mounted correctly if the unit is to operate reliably. Please take care to observe the following points:

- Voltage range stated is at the power connector, not at the power source.
- The power supply must be mounted close to the unit, with usually not more than 6 feet (1.8 m) of cable between the supply and the operator interface. Ideally, the shortest length possible should be used.
- The wire used to connect the operator interface's power supply should be at least 22-gage wire suitably rated for the temperatures of the environment to which it is being installed. If a longer cable run is used, a heavier gage wire should be used. The routing of the cable should be kept away from large contactors, inverters, and other devices which may generate significant electrical noise.
- A power supply with an NEC Class 2 or Limited Power Source (LPS) and SELV rating is to be used. This type of power supply provides isolation to accessible circuits from hazardous voltage levels generated by a mains power supply due to single faults. SELV is an acronym for "safety extra-low voltage." Safety extra-low voltage circuits shall exhibit voltages safe to touch both under normal operating conditions and after a single fault, such as a breakdown of a layer of basic insulation or after the failure of a single component has occurred. A suitable disconnect device shall be provided by the end user.
- Peak efficiency (GRAC0001) occurs at the low side of the voltage range (approx. 12 V), recommended for high temperature applications.

EMC INSTALLATION GUIDELINES

Visit <http://www.redlion.net/emi> for more information on EMI guidelines, Safety and CE issues as they relate to Red Lion products.

For GEXRACK1 connection, recommend Tripp Lite Model: U023-006 6 ft cable.

I/O MODULE INSTALLATION

The physical order of all installed modules must match the modules order as set in Crimson database. Torque screws to 6.0 pound-force inch [96 ounce-force inch] (0.68 Nm).



WARNING - Disconnect all power to the unit before installing or removing modules.

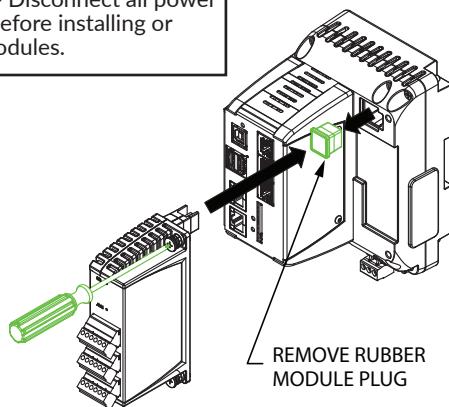

**COMMUNICATING WITH THE CONTROLLER
CONFIGURING AN EDGE CONTROLLER**

The Controller is configured using Crimson[®] software. Crimson software is available as a no charge download from Red Lion's website. Crimson updates for new features and drivers are posted on the website as they become available. By configuring the Edge Controller using the latest Crimson version, you are assured that your unit has the most up to date feature set. Crimson software can configure the controller through the RS232 PGM port, USB port, ethernet port or SD card.

The USB port is connected using a standard USB cable with a Type B connector. The driver needed to use the USB port will be installed as part of Crimson configuration.

The RS232 PGM port uses a programming cable made by Red Lion to connect to the DB9 COM port of your computer. If you choose to make your own cable, use the "Graphite Edge Controller Port Pin Out Diagram" for wiring information.

The SD card can be used to program a controller by placing a configuration file and firmware on the SD card. The card is then inserted into the target controller and powered. Refer to the Crimson literature for more information on the proper names and locations of the files.

SYSTEM LEDS

COLOR	STATUS
GREEN (STS)	Bootloader/Power
GREEN (SD)	File system SD Card

USB HOST LEDS

COLOR	STATUS
OFF	Not operational
RED	Error
GREEN	Normal operation

USB, DATA TRANSFERS FROM THE SD CARD



WARNING - Do not connect or disconnect cables while power is applied unless area is known to be non-hazardous.

In order to transfer data from the SD card via the USB port, a driver must be installed on your computer. This driver is installed with Crimson software and is located in the folder C:\Program Files\Red Lion Controls\Crimson 3.x\Device\ after installation. This may have already been accomplished if your controller was configured using the USB port.

Once the driver is installed, connect the controller to your PC with a USB cable, and follow "Mounting the SD" instructions in the Crimson 3.x user manual.

INSERTION/REMOVAL OF THE SD CARD

Insert the SD card into the slot provided with the card oriented as shown. The card is inserted properly when the end of the card is flush with the Edge Controller case. To remove the SD card, push in slightly on the card.

WARNING: Do not remove the SD card while power is applied.

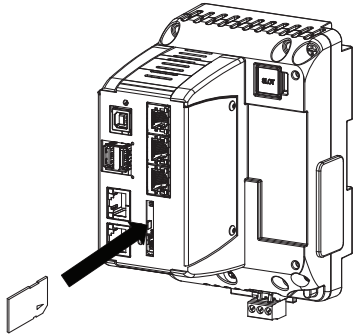

CABLES AND DRIVERS

Red Lion has a wide range of cables and drivers for use with many different communication types. A list of these drivers and cables along with pin outs is available from Red Lion’s website. New cables and drivers are added on a regular basis. If making your own cable, refer to the “Port Pin Outs” that corresponds to your specific model for wiring information.

ETHERNET COMMUNICATIONS

Ethernet communications can be established at either 10 BASE-T or 100 BASE-TX. The Graphite unit’s RJ45 jack is wired as a NIC (Network Interface Card). It auto-detects remote transmit and receive pairs and correctly assigns the transmit and receive pairs. This feature enables the user to use whichever type of cable (cross-over or straight) is available.

The Ethernet connector contains two LEDs. A yellow LED in the upper right, and a green LED in the upper left. The LEDs represent the following statuses:

LED COLOR	DESCRIPTION
YELLOW solid	Link established.
YELLOW flashing	Data being transferred.
GREEN (OFF)	10 BASE-T Communications
GREEN (ON)	100 BASE-TX Communications

A 12-digit MAC address label is provided for each Ethernet port. Refer to the Crimson manual and Red Lion’s website for additional information on Ethernet communications.

RS232 PORTS

The Edge Controller has a single RS232 port. The port can be used for either master or slave protocols with any Graphite configuration.

GRAPHITE RS232 TO A PC			
Gxx: RJ12	Name	PC: DB9	Name
4	COMM	1	DCD
5	Tx	2	Rx
2	Rx	3	Tx
	N/C	4	DTR
3	COMM	5	GND
	N/C	6	DSR
1	CTS	7	RTS
6	RTS	8	CTS
	N/C	9	RI

RS422/485 COMMS PORT

The controller has two RS422/485 ports. These ports can be configured to act as either RS422 or RS485.

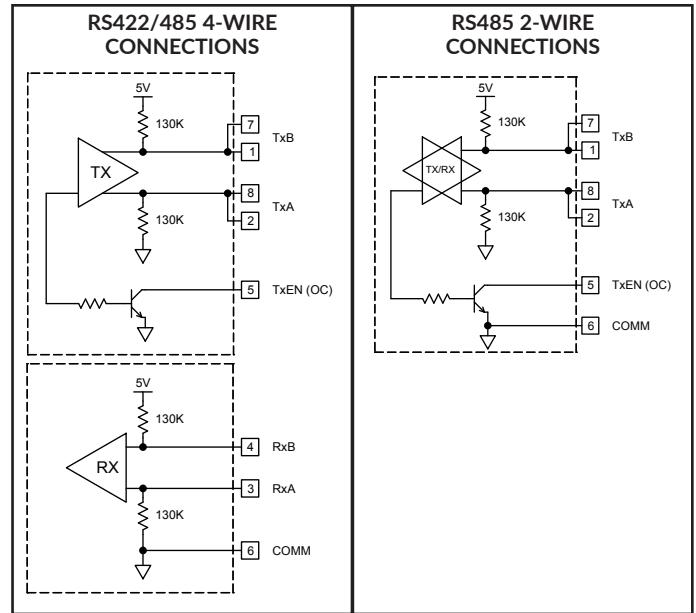

Note: All Red Lion devices connect A to A and B to B. Refer to www.redlion.net for additional information.

Examples of RS485 2-Wire Connections

GRAPHITE TO RED LION RJ11			
GXX: RJ45	Name	RLC: RJ11	Name
5	TxEN	2	TxEN
6	COMM	3	COMM
1	TxB	5	B-
2	TxA	4	A+

DH485 COMMUNICATIONS

The Graphite Edge Controller’s RS422/485 COMMS port can also be used for Allen Bradley DH485 communications.

GRAPHITE TO AB SLC 500			
RJ45: RLC	Name	RJ45: A-B	Name
1	TxB	1	A
2	TxA	2	B
3, 8	RxA	-	24 V
4, 7	RxB	-	COMM
5	TxEN	5	TxEN
6	COMM	4	SHIELD
4, 7	TxB	-	COMM
3, 8	TxA	-	24 V

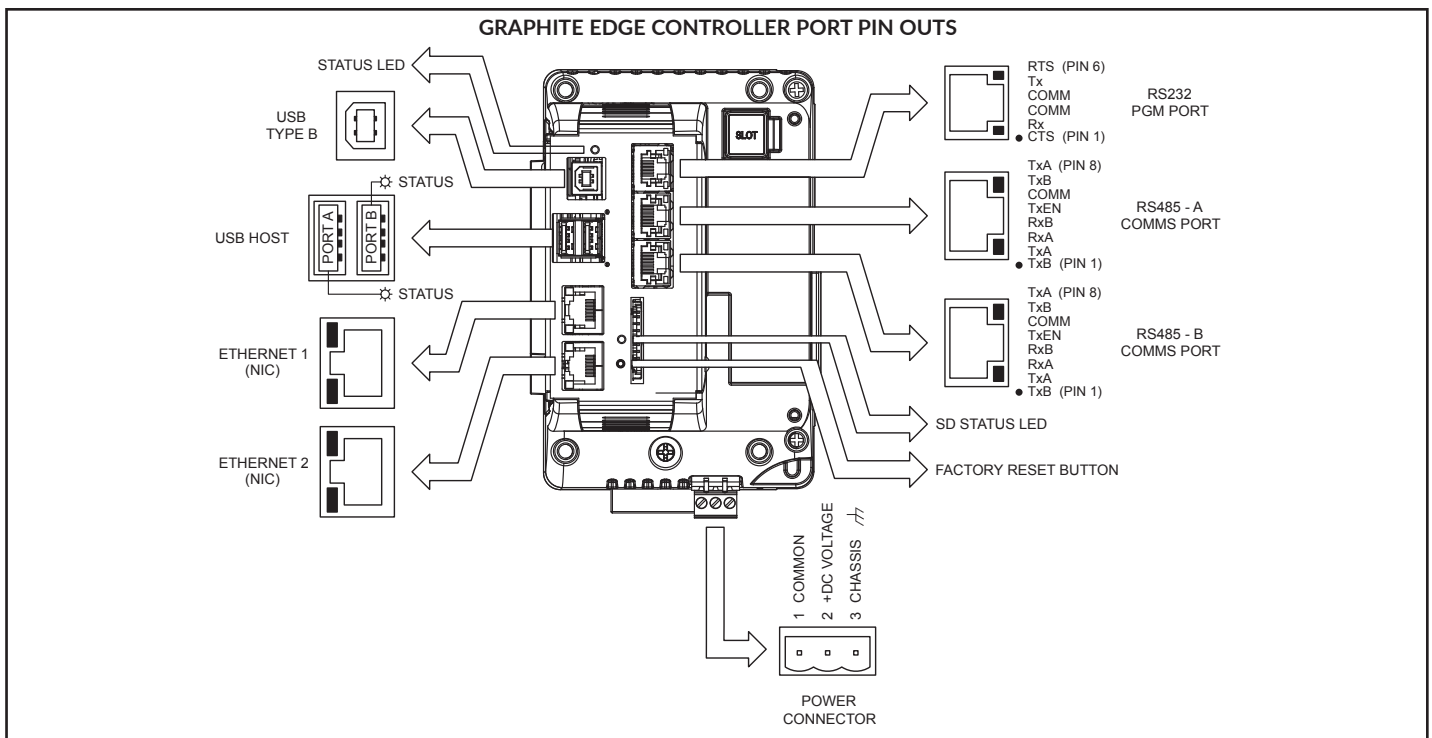

SOFTWARE/UNIT OPERATION

CRIMSON® SOFTWARE

Crimson software is available as a no charge download from Red Lion's website. The latest version of the software is always available from the website, and updating your copy is free.

FACTORY RESET BUTTON

The factory reset button is located on the front of the unit. Refer to Crimson 3 System Console Technical Note at www.redlion.net/TNIA22 for access procedure and available options.

On products configured with Crimson 3.2 software, the reset button is used to override the Crimson 3.2 System Web Server enable property. Pressing the reset button for a period greater than 2.5 seconds (until a high pitch beep is heard) will enable the System Web Server once released. Pressing and releasing the reset button briefly (until a low pitch beep is heard) will disable the System Web Server

BATTERY & TIME KEEPING



WARNING - EXPLOSION HAZARD - Disconnect power and ensure the areas is known to be non-hazardous before servicing/replacing the unit and before installing or removing I/O wiring and battery.

A battery is used to keep time when the unit is without power. Typical accuracy (at 25°C) of the time keeping is less than one minute per month drift. This battery does not affect the unit's memory, all configurations and data is stored in non-volatile memory.

Changing the Battery

To change the battery, first remove power to the unit. Remove all cables from the unit and any external module if installed. Remove the four TORX screws holding the metal cover to the unit, two per side. Slide the metal cover forward to gain access to the battery. Remove the old battery* from the holder and replace with the new battery. Replace metal cover with the four TORX screws. Reinstall external module if equipped, reconnect cables and re-apply power. Using Crimson software, enter the correct time and date.

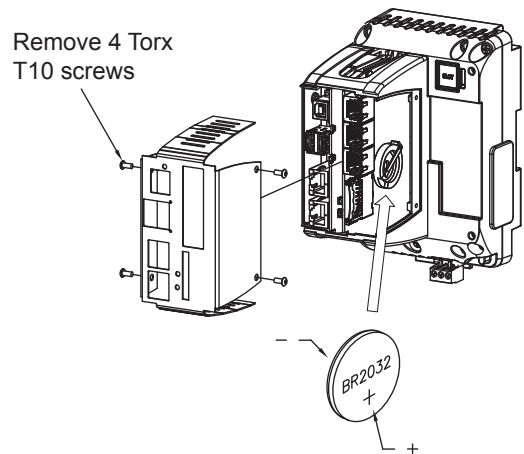

* Please note that the old battery must be disposed of in a manner that complies with your local waste regulations. The battery must not be disposed of in fire, or in a manner whereby it may be damaged and its contents could come into contact with human skin.

The battery used by the Graphite Edge Controller is an industrial temperature grade (-40°C to 85°C) lithium type BR2032.

RED LION CONTROLS TECHNICAL SUPPORT

If for any reason you have trouble operating, connecting, or simply have questions concerning your new product, contact Red Lion's technical support.

Support: support.redlion.net

Website: www.redlion.net

Inside US: +1 (877) 432-9908

Outside US: +1 (717) 767-6511

Red Lion Controls, Inc.

35 Willow Springs Circle York, PA 17406

ORDERING INFORMATION

DESCRIPTION	PART NUMBER
Graphite Edge Controller	GRAC0001

A listing of the entire Graphite family of products and accessories can be found at www.redlion.net.

COPYRIGHT

©2023 Red Lion Controls, Inc. All Rights Reserved. The terms Red Lion, the Red Lion logo, Graphite and Crimson are registered trademarks of Red Lion Controls. All other marks are the property of their respective owners.

LIMITED WARRANTY

(a) Red Lion Controls Inc. (the "Company") warrants that all Products shall be free from defects in material and workmanship under normal use for the period of time provided in "Statement of Warranty Periods" (available at www.redlion.net) current at the time of shipment of the Products (the "Warranty Period"). **EXCEPT FOR THE ABOVE-STATED WARRANTY, COMPANY MAKES NO WARRANTY WHATSOEVER WITH RESPECT TO THE PRODUCTS, INCLUDING ANY (A) WARRANTY OF MERCHANTABILITY; (B) WARRANTY OF FITNESS FOR A PARTICULAR PURPOSE; OR (C) WARRANTY AGAINST INFRINGEMENT OF INTELLECTUAL PROPERTY RIGHTS OF A THIRD PARTY; WHETHER EXPRESS OR IMPLIED BY LAW, COURSE OF DEALING, COURSE OF PERFORMANCE, USAGE OF TRADE OR OTHERWISE.** Customer shall be responsible for determining that a Product is suitable for Customer's use and that such use complies with any applicable local, state or federal law.

(b) The Company shall not be liable for a breach of the warranty set forth in paragraph (a) if (i) the defect is a result of Customer's failure to store, install, commission or maintain the Product according to specifications; (ii) Customer alters or repairs such Product without the prior written consent of Company.

(c) Subject to paragraph (b), with respect to any such Product during the Warranty Period, Company shall, in its sole discretion, either (i) repair or replace the Product; or (ii) credit or refund the price of Product provided that, if Company so requests, Customer shall, at Company's expense, return such Product to Company.

(d) **THE REMEDIES SET FORTH IN PARAGRAPH (c) SHALL BE THE CUSTOMER'S SOLE AND EXCLUSIVE REMEDY AND COMPANY'S ENTIRE LIABILITY FOR ANY BREACH OF THE LIMITED WARRANTY SET FORTH IN PARAGRAPH (a).**

BY INSTALLING THIS PRODUCT, YOU AGREE TO THE TERMS OF THIS WARRANTY, AS WELL AS ALL OTHER DISCLAIMERS AND WARRANTIES IN THIS DOCUMENT.