

# NT328G Industrial Ethernet Managed Switch Series

Hardware Guide | October 2020  
LP1108 | Revision C



## **COPYRIGHT**

©2019-2020 Red Lion Controls, Inc. All rights reserved. Red Lion and the Red Lion logo are registered trademarks of Red Lion Controls, Inc. All other company and product names are trademarks of their respective owners.

Red Lion Controls, Inc.  
20 Willow Springs Circle  
York, PA 17406

## **CONTACT INFORMATION:**

### **AMERICAS**

Inside US: +1 (877) 432-9908  
Outside US: +1 (717) 767-6511  
**Hours:** 8 am-6 pm Eastern Standard Time  
(UTC/GMT -5 hours)

### **ASIA-PACIFIC**

Shanghai, P.R. China: +86 21-6113-3688 x767  
**Hours:** 9 am-6 pm China Standard Time  
(UTC/GMT +8 hours)

### **EUROPE**

Netherlands: +31 33-4723-225  
France: +33 (0) 1 84 88 75 25  
Germany: +49 (0) 1 89 5795-9421  
UK: +44 (0) 20 3868 0909  
**Hours:** 9 am-5 pm Central European Time  
(UTC/GMT +1 hour)

Website: [www.redlion.net](http://www.redlion.net)

Support: [support.redlion.net](http://support.redlion.net)

# Table of Contents

<b>Preface</b>	<b>1</b>
Disclaimer	1
Purpose	1
Audience	1
Prerequisite Knowledge	1
Compliance Information	1
FCC Statement	1
Déclaration de conformité FCC	2
Industry Canada	2
Safety Instructions	2
Document Conventions	3
Regulatory Information	4
Access to Hardware Interface	5
Trademark Acknowledgments	5
Document History and Related Publications	5
Related Documents	5
Additional Product Information	5
<b>Chapter 1 Introduction</b>	<b>7</b>
Overview	7
Features and Benefits	7
DIMENSIONS In inches (mm)	8
Model Layouts - Front	9
NT328G-20SFP	9
NT328G-04SFP	9
Model Layouts - Rear	9
1 AC Power Models	9
2 AC Power Models	9
Technical Specifications	10
NT328G-04SFP Specifications	10
NT328G-20SFP Specifications	11
Transceiver Characteristics	12
100Base SFP Fiber Transceiver Characteristics (NT328G-20SFP Model Only)	12
Gigabit SFP Fiber Transceiver Characteristics	12
10 Gigabit SFP+ Fiber Transceiver Characteristics	12
<b>Chapter 2 Installation</b>	<b>13</b>
Contents of Package	13
Rack Mounting the Switch	13
Connecting to Earth Ground	14
Alarm Relay Connecting	14
Power Connections	15

Terminal Block Connector .....	15
Connecting to the Ethernet Port (RJ45 Ethernet) .....	15
Connecting to the Ethernet Port (Fiber, SFP/SFP+) .....	15
LED Status Indications .....	16
Console Connection .....	17
Connect & Login to the Switch .....	17
CLI Initialization & Configuration (Optional) .....	17
CLI Command .....	17
Web Interface Initialization (Optional) .....	18
Web Browser Support .....	18
System Reset .....	18
Ordering Information .....	19
Accessories .....	19
<b>Service and Support Information .....</b>	<b>21</b>
Service Information .....	21
For Your Convenience: .....	21
Product Support .....	21
LIMITED WARRANTY .....	22

# Preface

## Disclaimer

While every effort has been made to ensure that this document is complete and accurate at the time of release, the information that it contains is subject to change. Red Lion Controls, Inc. is not responsible for any additions to or alterations of the original document. Industrial networks vary widely in their configurations, topologies, and traffic conditions. This document is intended as a general guide only. It has not been tested for all possible applications, and it may not be complete or accurate for some situations.

Users of this document are urged to heed warnings and cautions used throughout the document.

## Purpose

This guide provides an overview of the NT328G Rackmount Layer 3 Switch as implemented in the current version of software. These commands are used to set-up and execute applications on the device.

## Audience

This guide is intended for use by network administrators, system engineers or other operating personnel who are responsible for operating and maintaining networking equipment; consequently, it assumes a basic working knowledge of general switch functions.

## Prerequisite Knowledge

The reader must be familiar with the:

- Basic operations of the switch
- Security and activity monitoring constraints that limit how a command is implemented

## Compliance Information

### FCC Statement

This product complies with Part 15 of the FCC-A Rules.

Operation is subject to the following conditions:

1. This device may not cause harmful Interference
2. This device must accept any interference received, including interference that may cause undesired operation.

**Note:** This equipment has been tested and found to comply with the limits for a Class A digital device, pursuant to Part 15 of the FCC Rules. These limits are designed to provide reasonable protection against harmful interference in a residential installation. This equipment generates, uses, and can radiate radio frequency energy and, if not installed and used in accordance with the instructions, may cause harmful interference to radio communications. Operation of this device in a residential area is likely to cause harmful interference in which case the user will be required to correct the interference at his/her own expense.

### Déclaration de conformité FCC

Ce produit est conforme à la partie 15 des règles de la FCC –A

Utilisation est soumise aux conditions suivantes:

1. Ce dispositif ne doit pas causer des interférences nuisibles
2. Cet appareil doit accepter toute interférence reçue, y compris les interférences qui peuvent causer un mauvais fonctionnement.

**Note:** Cet équipement a été testé et jugé conforme aux limites de la classe A des appareils numériques, conformément à la partie 15 des règles de la FCC. Ces limites sont conçues pour fournir une protection raisonnable contre les interférences nuisibles dans une installation résidentielle. Cet équipement génère, utilise et peut émettre de l'énergie radiofréquence et, si il n'est pas installé et utilise conformément aux instructions, peut causer des interférences nuisibles aux communications radio. L'utilisation de cet appareil dans une zone résidentielle est susceptible de provoquer des interférences nuisibles, auquel cas l'utilisateur sera tenu de corriger les interférences à ses propres frais.

## Industry Canada

This Class A digital apparatus meets all requirements of the Canadian Interference Causing Equipment Regulations. Operation is subject to the following two conditions; (1) this device may not cause harmful interference, and (2) this device must accept any interference received, including interference that may cause undesired operation.

Cet appareillage numérique de la classe A répond à toutes les exigences de l'interférence canadienne causant des règlements d'équipement. L'opération est sujette aux deux conditions suivantes: (1) ce dispositif peut ne pas causer l'interférence nocive, et (2) ce dispositif doit accepter n'importe quelle interférence reçue, y compris l'interférence qui peut causer l'opération peu désirée.

## Safety Instructions

When a connector is removed during installation, testing, or servicing, or when an energized fiber is broken, a risk of ocular exposure to optical energy that may be potentially hazardous occurs, depending on the laser output power.

Lorsqu'un connecteur est retiré pendant l'installation, le test ou l'entretien, ou lorsqu'une fibre sous tension est brisée, un risque d'exposition oculaire à une énergie optique potentiellement dangereuse se produit, selon la puissance de sortie du laser.

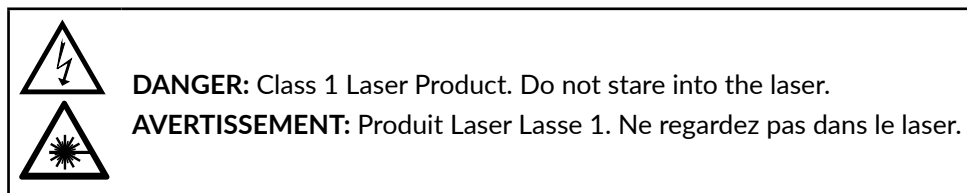



The primary hazards of exposure to laser radiation from an optical-fiber communication system are:

- Damage to the eye by accidental exposure to a beam emitted by a laser source.
- Damage to the eye from viewing a connector attached to a broken fiber or an energized fiber.

Les principaux dangers de l'exposition au rayonnement laser provenant d'un système de communication à fibres optiques sont:

- Dommages à l'œil par exposition accidentelle à un faisceau émis par une source laser.
- Dommages pour les yeux dus au fait de voir un connecteur relié à une fibre cassée ou à une fibre sous tension.

The equipment has hot surfaces.

	<b>DANGER:</b> Hot Surface. During operation, take care to avoid coming into contact with a hot surface. Do not touch it over 1 second.
	<b>AVERTISSEMENT:</b> Surface chaude! Pendant l'opération, en prenant soin d'éviter d'entrer en contact avec une surface chaude. Ne le touchez pas plus d'une seconde.

If the equipment is used in a manner not specified by the manufacturer, the protection provided by the equipment may be impaired. Changes or modifications to the equipment, which are not approved by the party responsible for compliance, could affect the user's authority to operate the equipment.

Si l'équipement est utilisé d'une manière non spécifiée par le fabricant, la protection fournie par l'équipement peut être compromise. Les changements ou modifications apportés à l'équipement, qui ne sont pas approuvés par la partie responsable de la conformité, pourraient affecter le pouvoir de l'utilisateur d'utiliser l'équipement.

## Document Conventions

The following conventions are used in this manual to emphasize information that will be of interest to the reader.

### Danger

	<b>DANGER:</b> The described activity or situation might or will cause personal injury. <b>AVERTISSEMENT:</b> L'activité ou la situation décrite pourrait ou causera des blessures corporelles.
--	--

### Warning

	<b>WARNING:</b> The described activity or situation might or will cause equipment damage. <b>AVERTISSEMENT:</b> L'activité ou la situation décrite peut ou causera des dommages matériels.
---	---

### Caution

	<b>CAUTION:</b> The described activity or situation might or will cause service interruption or degradation. <b>AVERTISSEMENT:</b> L'activité ou la situation décrite peut ou causera une interruption ou une dégradation du service.
---	--

If the equipment is used in a manner not specified by the manufacturer, the protection provided by the equipment may be impaired.

## Regulatory Information

<b>Product Safety</b>
UL 61010 Ordinary Locations
ANSI/ISA-12.12.01, Class I and II, Division 2 and Class III, Divisions 1 and 2 Groups A, B, C and D Hazardous Locations
C22.2 No. 61010 Ordinary Locations
C22.2 No. 213 Class I, Division 2 Hazardous Locations
<b>EMI/EMC</b>
CFR 47, Part 15, Subpart B
Innovation, Science and Economic Development Canada ICES-003 Issue 6
ANSI C63.4:2014
EN 61000-6-2 Generic standards - Immunity standard for industrial environments
EN 61000-6-4 Generic standards - Emission standard for industrial environments
IEC 61000-4-2 (ESD)
IEC 61000-4-3 (Radio-Frequency Electromagnetic Field)
IEC 61000-4-4 (Fast Transient)
IEC 61000-4-5 (Surge)
IEC 61000-4-6 (Radio-Frequency Continuous Conducted)
IEC 61000-4-8 (Power Frequency Magnetic Field)
IEC 61000-4-11 (Voltage Dips, Short Interruptions)
IEC 61000-4-16 (Mains Frequency Voltage)
IEC 61000-4-18 (Damped Oscillatory Wave)
<b>Shock &amp; Vibration</b>
IEC 60068-2-6: 2 g @ 5-500 Hz 2 g Tri-Axle
IEC 60068-2-27: 50 g @ 11 ms Tri-Axle
IEC 60068-2-32: Test Ed: Free Fall
<b>Rail</b>
EN 50155, EN 50121 and EN 61373
<b>Other</b>
RoHS compliant



## Access to Hardware Interface

Access to the hardware interface is by a terminal (or computer with terminal emulation software).

Requirements for the terminal are:

- RS-232 ASCII port
- Selectable transmission baud rate
- Full alphanumeric capability
- Selectable odd/even or no parity check

## Trademark Acknowledgments

Red Lion Controls acknowledges and recognizes ownership of the following trademarked terms used in this document.

- Ethernet is a registered trademark of Xerox Corporation.

All other company and product names are trademarks of their respective owners.

## Document History and Related Publications

The hard copy and electronic media versions of this document are revised only at major releases and therefore, may not always contain the latest product information. Tech Notes and/or product addendums will be provided as needed between major releases to describe any new information or document changes.

The latest online version of this document can be accessed through the Red Lion website at

[www.redlion.net/support/documentation](http://www.redlion.net/support/documentation).

## Related Documents

Available documents related to this product can be accessed at [www.redlion.net/support/documentation](http://www.redlion.net/support/documentation).

- LP1105 - NT328G Industrial Ethernet Managed Switch Software Guide

## Additional Product Information

Additional product information can be obtained by contacting the local sales representative or Red Lion through the contact numbers listed on the inside of the front cover.



# Chapter 1 Introduction

## Overview

The Red Lion® NT328G, Layer 3 rackmount industrial Ethernet switch, offers 28 high speed ports (24 Gigabit, 4 10 Gigabit) to meet the performance requirements of bandwidth intensive applications. Designed to meet current and future needs with reliable wire-speed switching performance and a flexible mix of copper and fiber ports, the NT328G's robust feature set includes network redundancy, advanced security, policy-based traffic control and easy-to-use configuration and management. Housed in a rugged IP30 metal enclosure, the switch is designed for long-life use in harsh industrial environments, including wide operating temperature conditions and hazardous locations.

## Features and Benefits

### PRODUCT HIGHLIGHTS

- 24 Gigabit Copper Ports or 8 Gigabit Copper Ports and 16 Gigabit SFP Ports
- 4 10G SFP+ Ports  
Supports 10G SFP+ Fiber or 1G Copper/ Fiber SFP Transceivers

### MANAGEMENT

- RMON (Monitors L1 to L2 Traffic)
- Configuration Backup/Restore
- DHCP Server/Client/Relay Agent with Option 61, Option 82
- IGMP v1, v2, v3
- SNMP v1, v2, v3
- Port Mirroring
- Event Log/Syslog
- Advanced VLAN Operations
- LLDP
- Web Browser Management
- CLI: Console, Telnet, SSH

### NETWORK REDUNDANCY

- High-Speed Ring Protocol with <20ms Heal Time
- Chain Protocols
- LACP (Port Trunking)
- Up to 14 Trunks per Switch
- Up to 8 Ports per Trunk
- IEEE 802.1D STP, IEEE 802.1w RSTP, IEEE 802.1s, 802.1Q MSTP

### QoS/RATE LIMITING/TRAFFIC CONTROL

- QoS: Traffic Policing, Traffic Shaping, Queue Scheduling Policy/Profile-based Access Control List:
- IP/MAC/TCP/UDP/ToS/DSCP
- CoS/DSCP: SPQ, WRR, SPQ+WRR
- Rate Limiting / Traffic Control: Storm Control
- Multicast/Unicast Filtering

### ROUTING

- GVRP
- IEEE 802.1 AD (QinQ)
- VRRP v2, v3
- RIP v1, v2
- OSPF
- Static Routing
- L3 Forwarding

### SECURITY

- SNMP v3
- SSH, SSL, HTTPS
- Access Control List
- 802.1X port authentication
- 802.1X user login authentication
- IP Source Guard (DHCP)

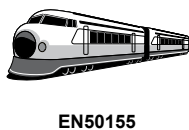

## DIMENSIONS In inches (mm)

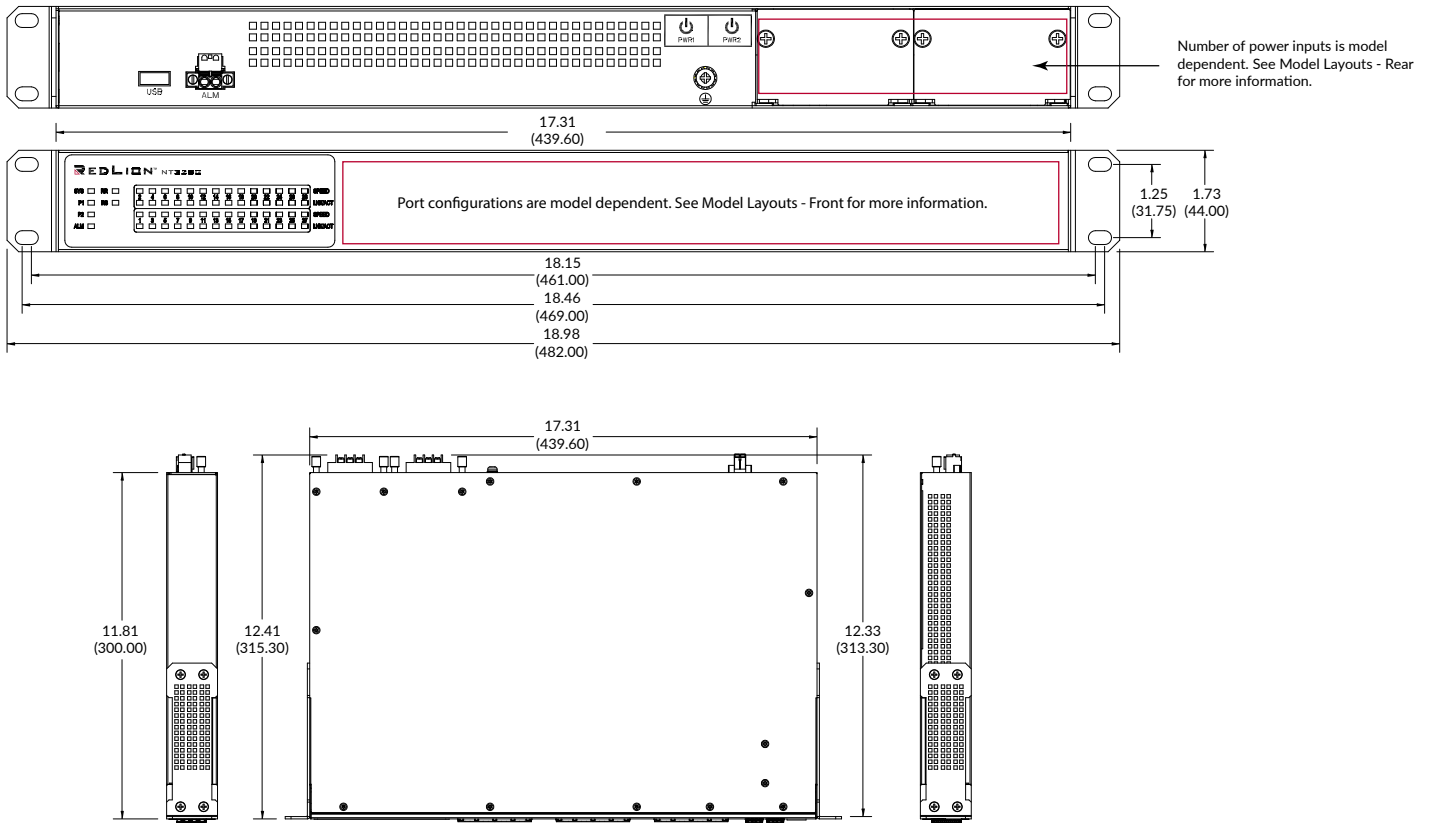

## Model Layouts - Front

### NT328G-20SFP

8 10/100/1000Base T(X) Ports, 16 100/1000Base SFP Ports and 4 10G SFP+ Ports

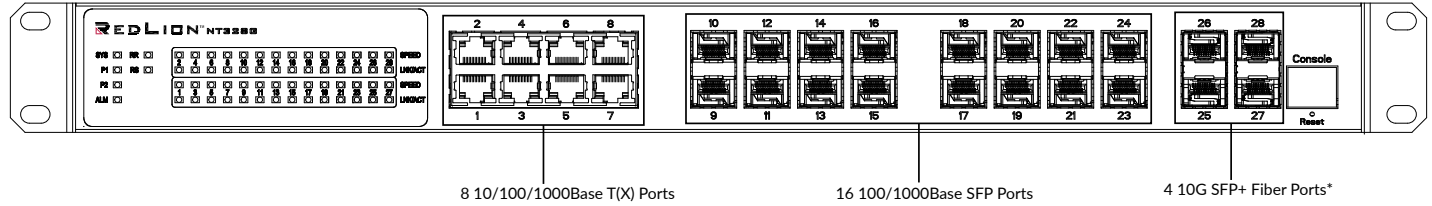

\*Backwards compatible to 1G copper and fiber SFP transceivers.

### NT328G-04SFP

24 10/100/1000Base T(X) Ports and 4 10G SFP+ Ports

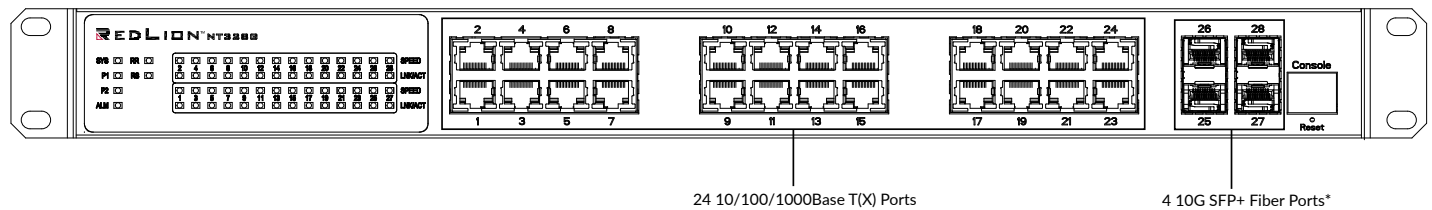

\*Backwards compatible to 1G copper and fiber SFP transceivers.

## Model Layouts - Rear

### 1 AC Power Models

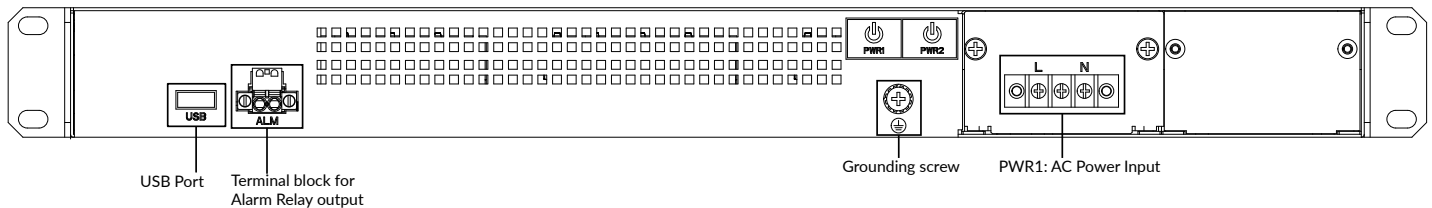

### 2 AC Power Models

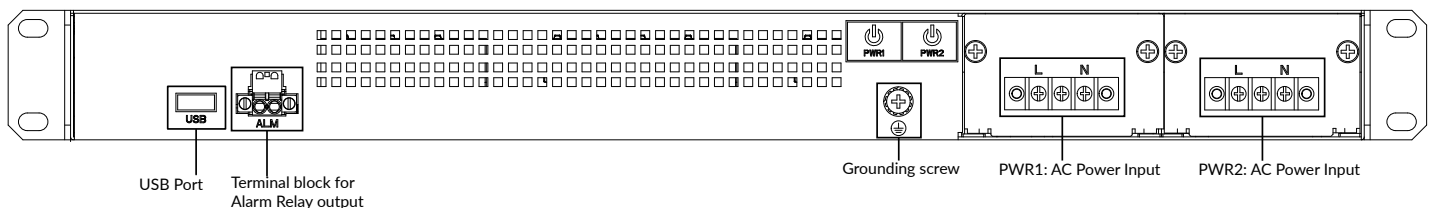

## Technical Specifications

ETHERNET					
Ethernet Interface	100/1000Base SFP slots or 10/100/1000BaseT(X) for 24 gigabit ports 10G SFP+ (1G SFP backward compatible) for 4 SFP+ slots				
POWER					
Power Input Options	Input Voltage Range	Maximum Power Consumption			
Single/Dual AC inputs	100-240 VAC, 50 Hz - 60 Hz	35 W			
ENVIRONMENTAL AND COMPLIANCES					
Operating Temperature Range	Storage Temperature Range	Humidity (non-condensing)	Operating Altitude	Operating Condition	
-40 to 75 °C	-40 to 85 °C	5 to 95% RH	Up to 10,000 ft	OVC II and PD 2	
MECHANICAL					
Ingress Protection	Height	Width	Depth	Weight	Installation Option
IP30	1.73" (44.00 mm)	17.31" (439.60 mm)	12.41" (315.30 mm)	7.19 lbs. (3.26 kg) (maximum, NT328G-20SFP-AC2)	19" rack mounting
RECOMMENDED MINIMUM WIRING CLEARANCE					
Back	2.00" (50.80 mm)				
Front	4.00" (101.60 mm)				

## NT328G-04SFP Specifications

NT328G-04SFP-AC1 SPECIFICATIONS	
Weight:	6.28 lbs. (2.85 kg)
Input Voltage:	100-240 VAC
Steady Input Current:	470 mA @ 120 VAC
BTU/hr:	192 @ 120VAC

NT328G-04SFP-AC2 SPECIFICATIONS	
Weight:	6.75 lbs. (3.06 kg)
Input Voltage:	100-240 VAC
Steady Input Current:	470 mA @ 120 VAC
BTU/hr:	192 @ 120 VAC

NETWORK AND MEDIA SPECIFICATIONS	
10BaseT:	≥Cat3 Cable
100BaseTX:	≥Cat5 Cable
1000BaseT:	≥Cat5e Cable
1000BaseSX Multimode:	50-62.5/125µm
1000BaseLX Singlemode:	7-10/125µm
10GBaseSR Multimode:	50/125µm
10GBaseLR Singlemode:	9/125µm

CONNECTOR SPECIFICATIONS	
10/100/1000BaseT(X):	Twenty-four (24) RJ45 TX Copper Ports
1000 BaseT SFP Port:	Up to four (4) RJ45 SFP Copper Transceiver Ports
1000 BaseSX/LX SFP Port:	Up to four (4) LC SFP Fiber Transceiver Ports
10G BaseSR/LR SFP Port:	Up to four (4) LC SFP Fiber Transceiver Ports

## NT328G-20SFP Specifications

NT328G-20SFP-AC1 SPECIFICATIONS	
Weight:	6.72 lbs. (3.05 kg)
Input Voltage:	100-240 VAC
Steady Input Current:	500 mA @ 120 VAC
BTU/hr:	205 @ 120 VAC

NT328G-20SFP-AC2 SPECIFICATIONS	
Weight:	7.19 lbs. (3.26 kg)
Input Voltage:	100-240 VAC
Steady Input Current:	500 mA @ 120 VAC
BTU/hr:	205 @ 120 VAC

NETWORK MEDIA SPECIFICATIONS	
10BaseT:	≥Cat3 Cable
100BaseTX:	≥Cat5 Cable
1000BaseT:	≥Cat5e Cable
100BaseFX, 1000BaseSX Multimode:	50-62.5/125μm
100BaseFXE, 1000BaseLX Singlemode:	7-10/125μm
10GBaseSR Multimode:	50/125μm
10GBaseLR Singlemode:	9/125μm

CONNECTOR SPECIFICATIONS	
10/100/1000BaseT(X):	Eight (8) RJ45 TX Copper Ports
100BaseFX SFP Port:	Up to sixteen (16) LC SFP Fiber Transceiver Ports
1000BaseT SFP Port:	Up to twenty (20) RJ45 SFP Copper Transceiver Ports
1000BaseSX/LX SFP Port:	Up to twenty (20) SFP Fiber Transceiver Ports
10GBaseSR/LR SFP Port:	Up to four (4) LC SFP Fiber Transceiver Ports

## Transceiver Characteristics

### 100Base SFP Fiber Transceiver Characteristics (NT328G-20SFP Model Only)

Fiber Mode	MM	SM	SM	SM
Fiber Length*	2 km	15 km	40 km	80 km
TX Power Min.	-19 dBm	-15 dBm	-5 dBm	-5 dBm
RX Sensitivity Max.	-31 dBm	-34 dBm	-34 dBm	-34 dBm
Wavelength	1310 nm	1310 nm	1310 nm	1550 nm
Laser Type	FP	FP	FP	DFB

### Gigabit SFP Fiber Transceiver Characteristics

Fiber Mode	MM	SM	SM	SM
Fiber Length*	550m @ 50/125 $\mu$ m 275m @ 62.5/125 $\mu$ m	10 km	40 km	80 km
TX Power Min	-9.5 dBm	-9.5 dBm	-2 dBm	0 dBm
RX Sensitivity Max	-17 dBm	-20 dBm	-22 dBm	-24 dBm
Wavelength	850 nm	1310 nm	1310 nm	1550 nm
Laser Type	VCSEL	FP	DFB	DFB

### 10 Gigabit SFP+ Fiber Transceiver Characteristics

Fiber Mode	MM	SM	SM	SM
Fiber Length*	300 m	10 km	40 km	80 km
TX Power Min	-7.3 dBm	-8.2 dBm	-4.7 dBm	-1.0 dBm
RX Sensitivity Max	-11.1 dBm	-12.6 dBm	-15.8 dBm	-23 dBm
Wavelength	850 nm	1310 nm	1550 nm	1550 nm
Laser Type	VCSEL	DFB	EML	EML

\* Fiber Length distances represent typical performance. Link budgets should be evaluated based on specific application conditions.

\*\* SFP transceivers sold separately.



# Chapter 2 Installation

## Contents of Package

Carefully remove the switch and accessories from the shipping container and inspect them for damage. Contact Red Lion immediately if any damage is discovered.

Please verify that the box contains the following items:

- (1) Rack-mount Ethernet switch
- (2) Rack-mount brackets
- (4) Screws for brackets
- (1) Console cable
- (1) ALM terminal block (2-pin)
- (1) Documentation CD
- (12) RJ45 and (2) SFP dust covers (NT328G-04SFP)
- (4) RJ45 and (10) SFP dust covers (NT328G-20SFP)

## Rack Mounting the Switch

When mounting the switch, practice good safety habits. Relay rack mounting normally requires at least two people.

1. Obtain the tools required for mounting the hardware.
2. Attach the mounting brackets to the switch by using the screws in the accessory kit.

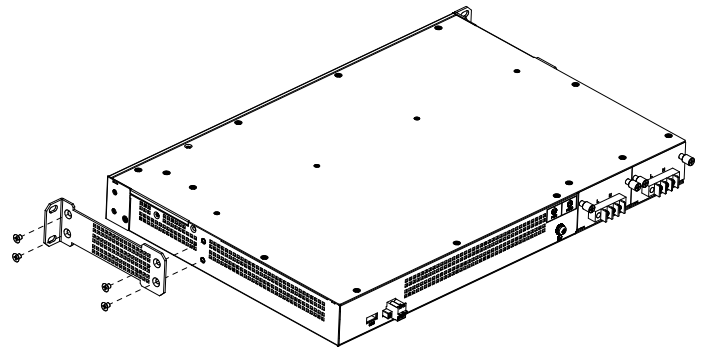

3. Secure the switch in its relay location on both the left and right sides of the mounting bracket. Tighten screws with 4.3-5.2 inch-lbs.

**Note:** The industrial control panel rated ambient temperature required is 75 °C min.

**Note:** La température ambiante nominale du panneau de commande industriel requis était de 75 °C min.

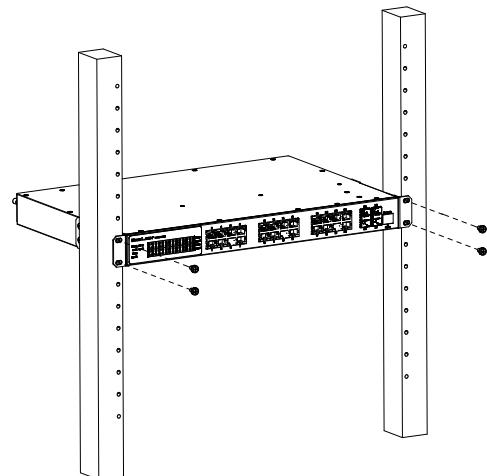

## Connecting to Earth Ground

The switch must be properly grounded for optimal system performance. The grounding connection is for both PE and FG.



**WARNING:** The grounding pin of the AC power connector and middle pin of the DC power terminal block have no function. Only use the device grounding screw for a correct installation.

**AVERTISSEMENT:** La broche de mise à la terre du connecteur d'alimentation secteur et la broche centrale du bloc de borne d'alimentation CC n'a aucune fonction. Utilisez uniquement la vis de mise à la terre de l'appareil pour une installation correcte.

Use 18AWG-12AWG wire rated 85 °C for power connection.

Tighten the grounding screw with 8.8-13.2 inch-lbs.

Use with Copper Conductors Only.

Utilisez un fil de 18AWG-12AWG évalué à 85 °C pour le raccordement électrique.

Serrer la vis de mise à la terre à 8.8-13.2 inch-lbs.

Utiliser uniquement avec des conducteurs en cuivre.

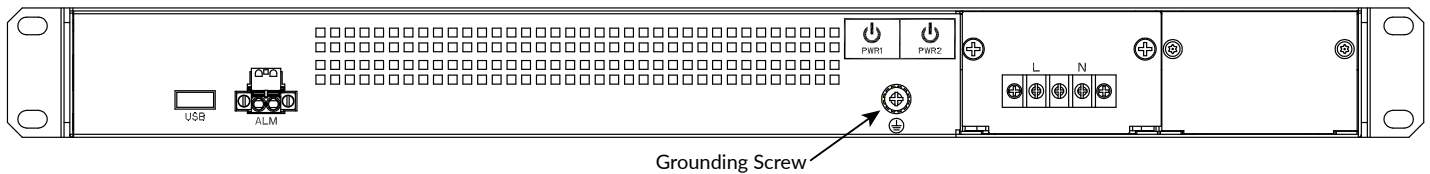

## Alarm Relay Connecting

The alarm relay output contacts have a current carrying capacity of 30 VDC. Contact 1A is a 2 pin terminal block that attaches to the NT328G's ALM port. The alarm relay contact is a "Normally open" contact that will close when it detects any power failures.

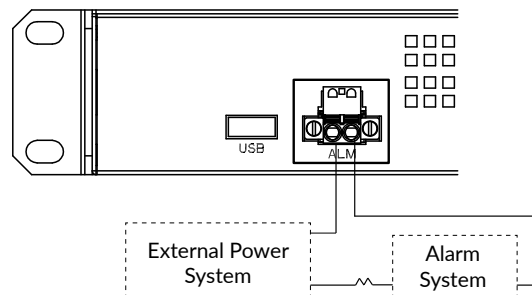
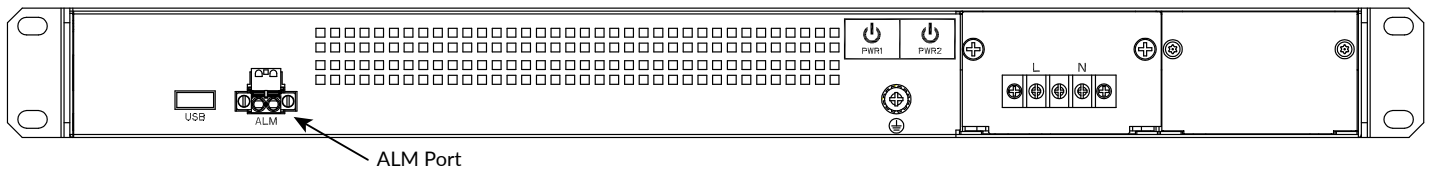

**Note:** Use 24 AWG wire rated 85 °C for connection. Tighten the screw with 8.8-13.2 inch-lb.

**Note:** Utilisez un fil de calibre 24 AWG à 85 °C pour la connexion. Serrer la vis à 8.8 - 13.2 inch-lb.

## Power Connections

### Terminal Block Connector

The switch can be powered from two UL61010-2-201 certified SELV power supplies (input range 100 V-240 V). The AC power connector is a 3P terminal block; “L” stands for Line and “N” stands for Neutral. Tighten the wire-clamp screws with Torque Value 1.7 inch-lbs to prevent the wires from being loosened.

After completing chassis installation, apply power to the fused power distribution panel feeding the chassis.

Use an Overcurrent Protection device (circuit breaker) rated 20 A at main power supply circuit.

**Note:** The AC power should be connected to a well-fused power supply. Use 18AWG-12AWG wire rated 85 °C for power connection. Tighten the screw with 8.8-13.2 inch-lbs.

**Note:** L'alimentation en courant alternatif doit être connectée à une alimentation bien protégée.

Utilisez un fil de 18AWG-12AWG évalué à 85 °C pour le raccordement électrique. Serrer la vis à 8.8-13.2 inch-lbs.

	<p><b>WARNING:</b> Ensure that all power sources to the chassis (power distribution panel) are turned off during the connection.</p> <p><b>AVERTISSEMENT:</b> Assurez-vous que toutes les sources d'alimentation du châssis (panneau de distribution d'alimentation) sont éteintes pendant la connexion.</p>
---	--

### Connecting to the Ethernet Port (RJ45 Ethernet)

The switch provides two types of electrical (RJ45) and optical (mini-GBIC) ports.

To connect the Ethernet port via RJ45:



- To connect to a PC, use a straight-through or a cross-over Ethernet cable.
- To connect the switch to an Ethernet device, use UTP (Unshielded Twisted Pair) or STP (Shielded Twisted Pair) Ethernet cables.

### Connecting to the Ethernet Port (Fiber, SFP/SFP+)

For available 100 or 1000 Mbps fiber ports, use the SFP LC style connectors. For available 10 Gbps ports (ports 25 - 28 only), use the SFP+ LC style connectors.

The connectors are available with multimode or singlemode transceivers.

The Optical Transceiver must use a UL Certificated Class 1 laser product that shall comply with CDRH 21CFR 1040.10 and 1040.11.

	<p><b>DANGER:</b> Never attempt to view optical connectors that might be emitting laser energy. Do not power up the laser product without connecting the laser to the optical fiber and putting the cover in position, as the laser outputs will emit infrared light.</p>
	<p><b>AVERTISSEMENT:</b> Ne tentez jamais de voir des connecteurs optiques qui émettent de l'énergie laser. N'allumez pas le produit laser sans connecter le laser à la fibre optique et en plaçant le couvercle en position, car les sorties laser émettront la lumière laser infrarouge.</p>

## LED Status Indications

SYSTEM STATUS INDICATORS		
LED NAME	INDICATOR/COLOR	CONDITION
SYS	On/Green	System is working normally
	Flashing/Green	System booting, or database saving or remote download is in-progress
	Off	System is not working or does not have power
P1	On/Green	P1 power line has power
	Off	P1 power line is disconnected or does not have power
P2	On/Green	P2 power line has power
	Off	P2 power line is disconnected or does not have power
Alarm	On/Red	Alarm event
	Off	No alarm
RR (Ring Role)	On/Green	One of 3 Ring groups is enabled and is in the Master role
	Off	Ring is in the slave role
RS (Ring Status)	On/Green	Ring failure occurs and is detected
	Off	No ring failure detected
PORT STATUS INDICATORS		
LED NAME	INDICATOR/COLOR	CONDITION
RJ45 Port Link/Act	On/Green	Ethernet link is up but no traffic is detected
	Flashing/Green	Ethernet link is up and there is traffic detected
	Off	Ethernet link is down
RJ45 Port Speed	On/Yellow	A 1000 Mbps connection is detected
	Off	No link detected or a 10 Mbps, 100 Mbps connection is detected
SFP Port Link (Port 9 to 24) (NT328G-20SFP)	On/Green	Ethernet link is up
	Flashing/Green	Ethernet link is up and there is traffic detected
	Off	Ethernet link is down
SFP Speed (100/1000M) (Port 9 to 24) (NT328G-20SFP)	On/Yellow	SFP port speed is 1000 Mbps
	Off	SFP port speed is 100 Mbps or link down
SFP+ (10G) Port Link (Port 25 to 28)	On/Green	Ethernet link is up
	Flashing/Green	Ethernet link is up and there is traffic
	Off	Ethernet link is down
SFP+ (10G) Speed (Port 25 to 28)	On/Yellow	SFP port speed is 10 Gbps
	Off	SFP port speed is 1 Gbps or link down

## Console Connection

The Console port is used for local management through a terminal emulator or a computer with terminal emulation software. Console port specifications are as follows:

- DB9 connector to connect to computer COM port
- Baud rate: 115200 bps
- 8 data bits, 1 stop bit
- Parity: None
- Flow Control: None

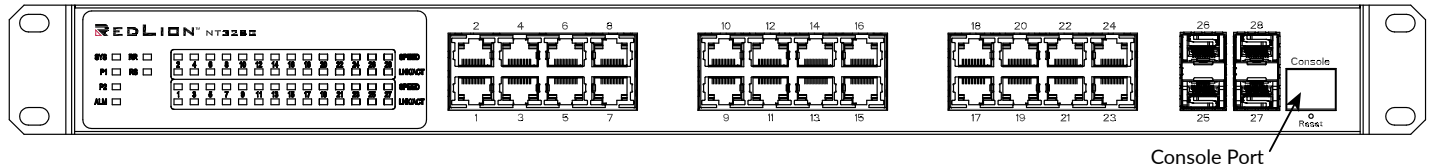

To connect the host PC to the console port, a RJ45 (male) connector to RS232 DB9 (female) connector cable is required. The RJ45 cable is connected to the CID port of the switch. The DB9 cable is connected to the PC COM port. The pin assignment of the console cable is shown below:

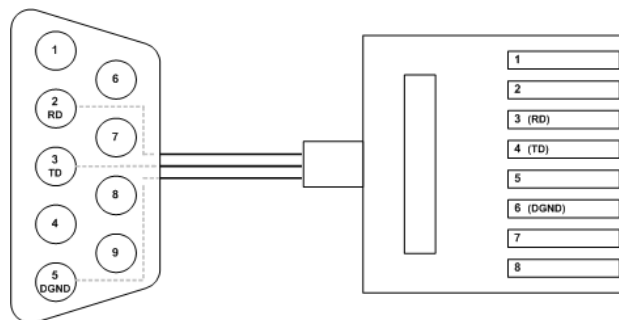

## Connect & Login to the Switch

1. Connect to the switch Ethernet port (RJ45 Ethernet port).
2. Factory default IP: 192.168.1.201/24
3. Login with default user name and password.  
**User name: admin**  
**Password: admin**

## CLI Initialization & Configuration (Optional)

1. Connect to the switch Ethernet port (RJ45 Ethernet port).
2. Key-in the command under Telnet: **telnet 192.168.1.201**
3. Login with default user name and password.  
**User name: admin**  
**Password: admin**
4. Change the IP with commands listed below.

## CLI Command

```
enable  
configure  
interface vlan 1  
ip-address xxx.xxx.xxx.xxx netmask xxx.xxx.xxx.xxx  
exit
```

## Web Interface Initialization (Optional)

### Web Browser Support

If Internet Explorer 7 (or newer version) is used, the following settings are recommended:

PARAMETER	SETTING
Language Script	Latin Based
Web Page Font	Times New Roman
Plain Text Font	Courier New
Encoding	Unicode (UTF-8)
Text Size	Medium

If Firefox is used, the following settings are recommended:

PARAMETER	SETTING
Web Page Font	Times New Roman
Encoding	Unicode (UTF-8)
Text Size	16

If Google Chrome is used, the following settings are recommended:

PARAMETER	SETTING
Web Page Font	Times New Roman
Encoding	Unicode (UTF-8)
Text Size	Medium

## System Reset

The reset button is provided to reboot the system without the need to remove power. If the switch is unresponsive, the user may need to push the reset button.

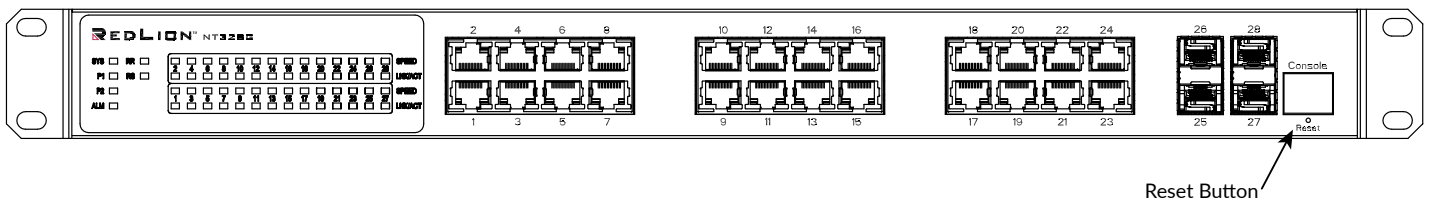

## Ordering Information

PART NUMBER	DESCRIPTION
NT328G-04SFP-AC1	28-port; Managed L3 Industrial Ethernet Switch (24 10/100/1000BaseT RJ45 ports; 4 Dual Mode (1000/10GBase) SFP expansion slots); one 100-240 VAC power input
NT328G-04SFP-AC2	28-port; Managed L3 Industrial Ethernet Switch (24 10/100/1000BaseT RJ45 ports; 4 Dual Mode (1000/10GBase) SFP expansion slots); two 100-240 VAC power inputs
NT328G-20SFP-AC1	28-port; Managed L3 Industrial Ethernet Switch (8 10/100/1000BaseT RJ45 ports; 20 Dual Mode (16 100/1000Base; 4 1000/10GBase) SFP expansion slots); one 100-240 VAC power input
NT328G-20SFP-AC2	28-port; Managed L3 Industrial Ethernet Switch (8 10/100/1000BaseT RJ45 ports; 20 Dual Mode (16 100/1000Base; 4 1000/10GBase) SFP expansion slots); two 100-240 VAC power inputs

## Accessories

PART NUMBER	DESCRIPTION
NTSFP-FX	100BaseFX multimode fiber SFP pluggable transceiver (LC style connector, 2km)
NTSFP-FXE-YY	100BaseFX singlemode fiber SFP pluggable transceiver (LC style connector)
NTSFP-TX	1000BaseT copper SFP pluggable transceiver
NTSFP-SX	1000BaseSX multimode fiber SFP pluggable transceiver (LC style connector, 550m)
NTSFP-LX-ZZ	1000BaseLX singlemode fiber SFP pluggable transceiver (LC style connector)
NT10GSFP-SR	10GBase multimode fiber SFP+ pluggable transceiver (LC style connector, 300m)
NT10GSFP-LR-ZZ	10GBase singlemode fiber SFP+ pluggable transceiver (LC style connector)
NT328G-AC-US	US Industrial High-Temp Power Cord Assembly for use with the NT328G (Cord Length: 7 Ft., Gauge/Conductor: 18/3, Temp. Rating: 105°C, Plug: NEMA 5-15, Voltage Rating: 300V)

Where: YY = 15, 40, or 80 for FX singlemode; ZZ = 10, 40, or 80 for singlemode.





# Service and Support Information

## Service Information

We sincerely hope that you never experience a problem with any of our products. If you do need service, call Red Lion at 1-877-432-9908 for Technical Support. A trained specialist will help you determine the source of the problem. Many problems are easily resolved with a single phone call. If it is necessary to return a unit to us, an RO (Repair Order) can be obtained on the Red Lion website.

Red Lion tracks the flow of returned material with our RO system to ensure speedy service. You must include this RO number on the outside of the box so that your return can be processed immediately.

Be sure to have your original purchase order number and date purchased available.

We suggest that you give us a repair purchase order number in case the repair is not covered under our warranty. You will not be billed if the repair is covered under warranty.

Please supply us with as many details about the problem as you can. The information you supply will be written on the RO form and supplied to the repair department before your unit arrives. This helps us to provide you with the best service, in the fastest manner. Repairs are completed as soon as possible. If you need a quicker turnaround, ship the unit to us by air freight. We give priority service to equipment that arrives by overnight delivery.

We apologize for any inconvenience that the need for repair may cause you. We hope that our rapid service meets your needs. If you have any suggestions to help us improve our service, please give us a call. We appreciate your ideas and will respond to them.

## For Your Convenience:

Please fill in the following and keep this manual with your Red Lion system for future reference.

P.O. #: \_\_\_\_\_ Date Purchased: \_\_\_\_\_  
Purchased From: \_\_\_\_\_  
Serial Number: \_\_\_\_\_

## Product Support

### Technical Support:

Inside US: +1 (877) 432-9908  
Outside US: +1 (717) 767-6511  
Support: [support.redlion.net](http://support.redlion.net)  
Hours: 8:00 am to 6:00 pm EST

Red Lion Controls  
20 Willow Springs Circle  
York, PA 17406  
Website: [www.redlion.net](http://www.redlion.net)

## LIMITED WARRANTY

(a) Red Lion Controls Inc. (the "Company") warrants that all Products shall be free from defects in material and workmanship under normal use for the period of time provided in "Statement of Warranty Periods" (available at [www.redlion.net](http://www.redlion.net)) current at the time of shipment of the Products (the "Warranty Period"). **EXCEPT FOR THE ABOVE-STATED WARRANTY, COMPANY MAKES NO WARRANTY WHATSOEVER WITH RESPECT TO THE PRODUCTS, INCLUDING ANY (A) WARRANTY OF MERCHANTABILITY; (B) WARRANTY OF FITNESS FOR A PARTICULAR PURPOSE; OR (C) WARRANTY AGAINST INFRINGEMENT OF INTELLECTUAL PROPERTY RIGHTS OF A THIRD PARTY; WHETHER EXPRESS OR IMPLIED BY LAW, COURSE OF DEALING, COURSE OF PERFORMANCE, USAGE OF TRADE OR OTHERWISE.** Customer shall be responsible for determining that a Product is suitable for Customer's use and that such use complies with any applicable local, state or federal law.

(b) The Company shall not be liable for a breach of the warranty set forth in paragraph (a) if (i) the defect is a result of Customer's failure to store, install, commission or maintain the Product according to specifications; (ii) Customer alters or repairs such Product without the prior written consent of Company.

(c) Subject to paragraph (b), with respect to any such Product during the Warranty Period, Company shall, in its sole discretion, either (i) repair or replace the Product; or (ii) credit or refund the price of Product provided that, if Company so requests, Customer shall, at Company's expense, return such Product to Company.

(d) **THE REMEDIES SET FORTH IN PARAGRAPH (c) SHALL BE THE CUSTOMER'S SOLE AND EXCLUSIVE REMEDY AND COMPANY'S ENTIRE LIABILITY FOR ANY BREACH OF THE LIMITED WARRANTY SET FORTH IN PARAGRAPH (a).**

**BY INSTALLING THIS PRODUCT, YOU AGREE TO THE TERMS OF THIS WARRANTY, AS WELL AS ALL OTHER DISCLAIMERS AND WARRANTIES IN THIS DOCUMENT.**