

# NT4008 Industrial Ethernet Managed Switch Series

Hardware Guide | December 2021  
LP1160 | Revision C



## **COPYRIGHT**

©2020-2021 Red Lion Controls, Inc. All rights reserved. Red Lion and the Red Lion logo are registered trademarks of Red Lion Controls, Inc. All other company and product names are trademarks of their respective owners.

Red Lion Controls, Inc.  
20 Willow Springs Circle  
York, PA 17406

## **CONTACT INFORMATION:**

### **AMERICAS**

Inside US: +1 (877) 432-9908  
Outside US: +1 (717) 767-6511  
**Hours:** 8 am-6 pm Eastern Standard Time  
(UTC/GMT -5 hours)

### **ASIA-PACIFIC**

Shanghai, P.R. China: +86 21-6113-3688 x767  
**Hours:** 9 am-6 pm China Standard Time  
(UTC/GMT +8 hours)

### **EUROPE**

Netherlands: +31 33-4723-225  
France: +33 (0) 1 84 88 75 25  
Germany: +49 (0) 1 89 5795-9421  
UK: +44 (0) 20 3868 0909  
**Hours:** 9 am-5 pm Central European Time  
(UTC/GMT +1 hour)

Website: [www.redlion.net](http://www.redlion.net)

Support: [support.redlion.net](http://support.redlion.net)

# Table of Contents

<b>Preface</b> .....	<b>1</b>
Disclaimer .....	1
Compliance Information .....	1
FCC Statement .....	1
Déclaration de conformité FCC .....	1
Industry Canada .....	2
Safety Instructions .....	2
Document Conventions .....	3
Regulatory Information .....	4
Access to Hardware Interface .....	5
Trademark Acknowledgments .....	5
Document History and Related Publications .....	5
Additional Product Information .....	5
<b>Chapter 1 Introduction</b> .....	<b>7</b>
Features and Benefits .....	8
NT4008-PN Specifications .....	10
NT4008-PN DIMENSIONS In inches (mm) .....	11
NT4008-DM2-PN Specifications .....	12
NT4008-DM2-PN DIMENSIONS In inches (mm) .....	13
LEDs .....	14
Transceiver Characteristics .....	15
100Base SFP Fiber Transceiver Characteristics .....	15
Gigabit SFP Fiber Transceiver Characteristics .....	15
<b>Chapter 2 Installation</b> .....	<b>17</b>
Contents of Package .....	17
Mounting the NT4008 Unit .....	17
DIN Rail Mounting Instructions .....	17
DIN Rail Removal Instructions .....	18
Panel Mounting NT4008 Models .....	18
Power Source .....	19
Connecting to Earth Ground .....	19
Configurable Alarm Relay Contact .....	20
Connecting to the Ethernet Port (RJ45 Ethernet) .....	20
Connecting to the Ethernet Port (Fiber, SFP) .....	21
Console Connection .....	21
Terminal .....	21
Cleaning .....	22
<b>Chapter 3 Accessing the Web Software Interface</b> .....	<b>23</b>
Ordering Information .....	24
Accessories .....	24

<b>Service and Support Information</b> .....	<b>25</b>
Service Information .....	25
For Your Convenience: .....	25
Product Support .....	25
LIMITED WARRANTY .....	26

# Preface

## Disclaimer

This hardware guide provides an overview of installation, maintenance and operation of the NT4008 Industrial Ethernet Managed Switch Series equipment. It is not intended as a step-by-step guide or a complete set of all procedures necessary and sufficient to complete all operations.

While every effort has been made to ensure that this document is complete and accurate at the time of release, the information that it contains is subject to change. Red Lion Controls, Inc. is not responsible for any additions to or alterations of the original document. Industrial networks vary widely in their configurations, topologies, and traffic conditions. This document is intended as a general guide only. It has not been tested for all possible applications, and it may not be complete or accurate for some situations.

Users of this document are urged to heed warnings and cautions used throughout the document.

## Compliance Information

### FCC Statement

This product complies with Part 15 of the FCC-A Rules.

Operation is subject to the following conditions:

1. This device may not cause harmful Interference
2. This device must accept any interference received, including interference that may cause undesired operation.

**Note:** This equipment has been tested and found to comply with the limits for a Class A digital device, pursuant to Part 15 of the FCC Rules. These limits are designed to provide reasonable protection against harmful interference in a residential installation. This equipment generates, uses, and can radiate radio frequency energy and, if not installed and used in accordance with the instructions, may cause harmful interference to radio communications. Operation of this device in a residential area is likely to cause harmful interference in which case the user will be required to correct the interference at his/her own expense.

### Déclaration de conformité FCC

Ce produit est conforme à la partie 15 des règles de la FCC-A

Utilisation est soumise aux conditions suivantes:

1. Ce dispositif ne doit pas causer des interférences nuisibles
2. Cet appareil doit accepter toute interférence reçue, y compris les interférences qui peuvent causer un mauvais fonctionnement.

**Note:** Cet équipement a été testé et jugé conforme aux limites de la classe A des appareils numériques, conformément à la partie 15 des règles de la FCC. Ces limites sont conçues pour fournir une protection raisonnable contre les interférences nuisibles dans une installation résidentielle. Cet équipement génère, utilise et peut émettre de l'énergie radiofréquence et, si il n'est pas installé et utilise conformément aux instructions, peut causer des interférences nuisibles aux communications radio. L'utilisation de cet appareil dans une zone résidentielle est susceptible de provoquer des interférences nuisibles, auquel cas l'utilisateur sera tenu de corriger les interférences à ses propres frais.

## Industry Canada

This Class A digital apparatus meets all requirements of the Canadian Interference Causing Equipment Regulations. Operation is subject to the following two conditions; (1) this device may not cause harmful interference, and (2) this device must accept any interference received, including interference that may cause undesired operation.

Cet appareillage numérique de la classe A répond à toutes les exigences de l'interférence canadienne causant des règlements d'équipement. L'opération est sujette aux deux conditions suivantes: (1) ce dispositif peut ne pas causer l'interférence nocive, et (2) ce dispositif doit accepter n'importe quelle interférence reçue, y compris l'interférence qui peut causer l'opération peu désirée.

## Safety Instructions



**WARNING:** Do not separate when energized.  
**AVERTISSEMENT:** Ne pas séparer lorsqu'il est sous tension.

When a connector is removed during installation, testing, or servicing, or when an energized fiber is broken, a risk of ocular exposure to optical energy that may be potentially hazardous occurs, depending on the laser output power.

Lorsqu'un connecteur est retiré pendant l'installation, le test ou l'entretien, ou lorsqu'une fibre sous tension est brisée, un risque d'exposition oculaire à une énergie optique potentiellement dangereuse se produit, selon la puissance de sortie du laser.



**DANGER:** Class 1 Laser Product. Do not stare into the laser.



**AVERTISSEMENT:** Produit Laser Classe 1. Ne regardez pas dans le laser.



The primary hazards of exposure to laser radiation from an optical-fiber communication system are:

- Damage to the eye by accidental exposure to a beam emitted by a laser source.
- Damage to the eye from viewing a connector attached to a broken fiber or an energized fiber.
- This device is designed for hazardous locations. SFP Fibers are manufactured by Red Lion Controls, Inc. Part numbers are: NTSFP-FX, NTSFP-FXE-15, NTSFP-FXE-40, NTSFP-FXE-80, NTSFP-SX, NTSFP-LX-10, NTSFP-LX-40, and NTSFP-LX-80.

Les principaux dangers de l'exposition au rayonnement laser provenant d'un système de communication à fibres optiques sont:

- Dommages à l'œil par exposition accidentelle à un faisceau émis par une source laser.
- Dommages pour les yeux dus au fait de voir un connecteur relié à une fibre cassée ou à une fibre sous tension.
- Ce dispositif est conçu pour les endroits dangereux. Les fibres SFP sont fabriquées par Red Lion Controls, Inc. Les références sont: NTSFP-FX, NTSFP-FXE-15, NTSFP-FXE-40, NTSFP-FXE-80, NTSFP-SX, NTSFP-LX-10, NTSFP-LX-40, et NTSFP-LX-80.

The equipment has hot surfaces.

	<b>DANGER:</b> Hot Surface. During operation, take care to avoid coming into contact with a hot surface. Do not touch it over 1 second.
	<b>AVERTISSEMENT:</b> Surface chaude! Pendant l'opération, en prenant soin d'éviter d'entrer en contact avec une surface chaude. Ne le touchez pas plus d'une seconde.

If the equipment is used in a manner not specified by the manufacturer, the protection provided by the equipment may be impaired. Changes or modifications to the equipment, which are not approved by the party responsible for compliance, could affect the user's authority to operate the equipment.

Si l'équipement est utilisé d'une manière non spécifiée par le fabricant, la protection fournie par l'équipement peut être compromise. Les changements ou modifications apportés à l'équipement, qui ne sont pas approuvés par la partie responsable de la conformité, pourraient affecter le pouvoir de l'utilisateur d'utiliser l'équipement.

## Document Conventions

The following conventions are used in this manual to emphasize information that will be of interest to the reader.

### Danger

	<b>DANGER:</b> The described activity or situation might or will cause personal injury. <b>AVERTISSEMENT:</b> L'activité ou la situation décrite pourrait ou causera des blessures corporelles.
--	--

### Warning

	<b>WARNING:</b> The described activity or situation might or will cause equipment damage. <b>AVERTISSEMENT:</b> L'activité ou la situation décrite peut ou causera des dommages matériels.
---	---

### Caution

	<b>CAUTION:</b> The described activity or situation might or will cause service interruption or degradation. <b>AVERTISSEMENT:</b> L'activité ou la situation décrite peut ou causera une interruption ou une dégradation du service.
---	--

If the equipment is used in a manner not specified by the manufacturer, the protection provided by the equipment may be impaired.

## Regulatory Information

<b>Product Safety</b>
UL 61010 Ordinary Locations
C22.2 No. 61010 Ordinary Locations
UL 121201 and CSA C22.2 No. 213 Class I, Division 2 Hazardous Locations
ATEX
Ⓜ II 3 G Ex ec nC IIC T4 Gc
UL 20 ATEX 2433X
EN IEC 60079-0:2018, EN IEC 60079-7: 2015 +A1:2018, EN IEC 60079-15:2019; IEC 60079-0, Edition 7, IEC 60079-7, Edition 5.1, IEC 60079-15, 5th Edition
<b>EMI/EMC</b>
CFR 47, Part 15, Subpart B
Innovation, Science and Economic Development Canada ICES-003 Issue 6
ANSI C63.4:2014
EN 61000-6-2 Generic standards - Immunity standard for industrial environments
EN 61000-6-4 Generic standards - Emission standard for industrial environments
IEC 61000-4-2 (ESD)
IEC 61000-4-3 (Radio-Frequency Electromagnetic Field)
IEC 61000-4-4 (Fast Transient)
IEC 61000-4-5 (Surge)
IEC 61000-4-6 (Radio-Frequency Continuous Conducted)
IEC 61000-4-8 (Power Frequency Magnetic Field)
<b>Shock &amp; Vibration</b>
IEC 60068-2-6: 2 g @ 5-500 Hz 2 g Tri-Axle
IEC 60068-2-27: 50 g @ 11 ms Tri-Axle
IEC 60068-2-32: Test Ed: Free Fall
<b>Rail</b>
EN 50155, EN 50121 and EN 61373
<b>Marine</b>
ABS Type Approval for Shipboard Applications; EMC Directive 2014/30EU; LV Directive 2014/35
<b>Designed to Comply With</b>
IEEE 1613 for Electric Utility Substations
NEMA TS1/TS2 for Traffic Control
IEC 61850-3
<b>Other</b>
RoHS compliant



## Access to Hardware Interface

Access to the hardware interface is by a terminal (or computer with terminal emulation software).

Requirements for the terminal are:

- RS-232 ASCII port
- Selectable transmission baud rate
- Full alphanumeric capability
- Selectable odd/even or no parity check

## Trademark Acknowledgments

Red Lion Controls acknowledges and recognizes ownership of the following trademarked terms used in this document.

- Ethernet is a registered trademark of Xerox Corporation.
- PROFINET® is a registered trademark of PROFIBUS and PROFINET International (PI).

All other company and product names are trademarks of their respective owners.

## Document History and Related Publications

The hard copy and electronic media versions of this document are revised only at major releases and therefore, may not always contain the latest product information. Tech Notes and/or product addendums will be provided as needed between major releases to describe any new information or document changes.

The latest online version of this document can be accessed through the Red Lion website at

[www.redlion.net/support/documentation](http://www.redlion.net/support/documentation).

## Additional Product Information

Additional product information can be obtained by contacting the local sales representative or Red Lion through the contact numbers and/or support e-mail address listed on the inside of the front cover.



# Chapter 1 Introduction

Red Lion's NT4008 Gigabit Managed Industrial Ethernet switches are certified to meet PROFINET PNIO v2.34 conformance class B (CC-B), RT Class 1 standards to ensure seamless integration into PROFINET networks using standard PLC configuration and management tools. A GSDML file is provided.

Housed in rugged IP30 metal enclosures, the switches offer -40 to 75 °C operating temperature, redundant 12-58 VDC power inputs, reverse polarity protection, LED link and activity status indication, a configurable alarm contact, and are certified for use in hazardous, marine and rail applications.

Two port configurations are available:

- Eight 10/100/1000 RJ45 ports
- Six 10/100/1000 RJ45 ports and two dual mode SFP slots for optional 100Base or 1000Base SFP transceivers

The NT4008 series is designed for ease of installation and years of trouble free operation with a robust feature set that includes DHCP Server, SNMP v1/v2c/v3, IGMP v1/v2/v3, LLDP, MRP, RSTP, MSTP, Fast Ring and Chain protocols, MAC/IP port security, Syslog, NTP, LACP/LAG (static and dynamic link aggregation), port mirroring, and Multicast/Broadcast storm protection.

For use in MRP topologies, MRM (MRP Manager) or MRC (MRP Client) configurations are available.

PART NUMBER	DESCRIPTION	TOTAL PORTS	10/100/1000 BaseT(X)	100/1000Base SFP*	MRP
NT-4008-000-PN-C	8-port Gigabit Managed Industrial Ethernet Switch (8 10/100/1000BaseT RJ45 ports), PNIO CC-B, MRC	8	8		MRC
NT-4008-000-PN-M	8-port Gigabit Managed Industrial Ethernet Switch (8 10/100/1000BaseT RJ45 ports), PNIO CC-B, MRM	8	8		MRM
NT-4008-DM2-PN-C	8-port Gigabit Managed Industrial Ethernet Switch (6 10/100/1000BaseT RJ45 ports, 2 Dual Mode 100/1000Base SFP expansion slots), PNIO CC-B, MRC	8	6	2	MRC
NT-4008-DM2-PN-M	8-port Gigabit Managed Industrial Ethernet Switch (6 10/100/1000BaseT RJ45 ports, 2 Dual Mode 100/1000Base SFP expansion slots), PNIO CC-B, MRM	8	6	2	MRM

DIN rail clip, panel mount, and console cable are included.

SFP Transceivers are sold separately.

For a complete list of features and certifications, see page 8. Additional information is also available in the NT4008 Software User's Guide.

## Features and Benefits

### SWITCH PROPERTIES

- Compact, space saving package
- Full IEEE 802.3 compliance
- Managed operation
- PROFINET PNIO v2.34, conformance Class B (CC-B), RT Class 1
- PROFINET redundancy: Media Redundancy Protocol (MRM & MRC - model dependent)
- Extended environmental specifications
- Supports full/half duplex operation
- Up to 16.0 Gb/s maximum throughput
- MDIX auto sensing cable
- Auto sensing speed and flow control
- Full wire speed communications
- Store-and-forward technology
- Redundant power inputs (12-58 VDC)
- Reverse polarity protection
- LED link/activity status indication
- Hardened metal IP30 DIN rail enclosure
- Supports up to 4k MAC addresses
- Latency (typical): < 2.1  $\mu$ s
- Configurable alarm contact
- 9k byte jumbo frame support
- Ethernet isolation: 1500 Vrms 1 minute
- MTBF: 300K hours; Telcordia SR-332

### MANAGEMENT

- Web-based management
- CLI: Console, Telnet
- RMON (monitors L1 to L2 traffic)
- sFlow
- Configuration backup/restore
- PROFINET GSDML file, PROFINET I/O parameters, I/O cyclic data
- MRP: Media redundancy (MRM & MRC - model dependent)
- DHCP Client
- DHCP Server
- DHCP Relay Agent
- DHCP Snooping
- IGMP v1/v2/v3
- SNMP v1/v2c/v3

### DIAGNOSTIC

- Port mirroring
- Syslog
- IEC 802.1ab Link Layer Discovery Protocol (LLDP)

### NETWORK REDUNDANCY

- PROFINET MRP, MRC, MRM
- Ring Protocol: Proprietary Ring & Chain <20 ms recovery
- IEEE 802.1D STP, IEEE 802.1w RSTP, IEEE 802.1s, 802.1Q MSTP
- Loop protection
- LAG/LACP: Static and dynamic link aggregation
  - Up to 4 groups per switch
  - Up to 8 ports per group

### MIBs

- RFC 2674 VLAN MIB
- RFC 2819 RMON (Group 1, 2, 3 & 9)
- RFC 1213 MIB II
- RFC 1215 TRAPS MIB
- RFC 4188 Bridge MIB
- RFC 4292 IP Forwarding Table MIB
- RFC 4293 Management Information Base for the Internet Protocol (IP)
- RFC 5519 Multicast Group Membership Discovery MIB
- RFC 2863 Interface Group MIB using SMI v2
- RFC 4133 Entity MIB version 3
- RFC 3411 SNMP Management Frameworks
- RFC 3414 User-based Security Model for SNMPv3
- RFC 3415 View-based access Control Model for SNMP
- IEEE 802.1AB LLDP-MIB
- TIA 1057 LLDP-MED
- IEEE 802.1 MSTP MIB
- IEEE 802.3ad

### TRAFFIC MANAGEMENT & QoS

- Priority: IEEE 802.1p QoS
- Number of queues per port: 8
- Policing, scheduling, and shaping
- QoS classification, remarking, and translation
- QoS assignment via Control Lists
- WRED congestion management

**VLANs**

- Max VLANs: 1024
- VLAN types: Port-based VLANs  
IEEE802.1Q tag-based VLANs  
IEEE802.1ad double tagging (Q in Q)

**COMMUNICATION**

- Supports full/half duplex operation

**SECURITY**

- SSH, SSL, HTTPS
- Port security: IP and MAC-based access control
- Storm Control: Multicast/Broadcast/Flooding
- Policy-based access control engine: 128 ACL rules per system
- SNMP v3



## NT4008-PN Specifications

CONNECTORS					
10/100/1000BaseT(X)	Eight (8) RJ45 TX Copper Ports				
NETWORK MEDIA					
10BaseT	≥Cat3 cable				
100BaseTX	≥Cat5 cable				
1000BaseT	≥Cat5e cable				
POWER					
Power Input Options	Input Voltage Range	Steady Input Range	BTU/hr		
Redundant Input Terminals; Reverse Polarity Protection	12-58 VDC, 0.95 A	280 mA @ 24 VDC	22.93 @ 24 VDC		
ENVIRONMENTAL AND COMPLIANCES					
Operating Temperature Range	Storage Temperature Range	Humidity (non-condensing)	Operating Altitude	Operating Condition	
-40 to 75 °C	-40 to 85 °C	5 to 95% RH	Up to 6561 ft (2000 m)	OVC II and PD 2	
MECHANICAL					
Ingress Protection	Height	Width	Depth	Weight	Installation Options
IP30	5.12" (130.00 mm)	2.44" (62.00 mm)	4.13" (105.00 mm)	1.55 lbs (0.70 kg)	DIN rail or panel mount
RECOMMENDED MINIMUM WIRING CLEARANCE					
Front	2" (50.8 mm)				
Top	2" (50.8 mm)				

# NT4008-PN DIMENSIONS In inches (mm)

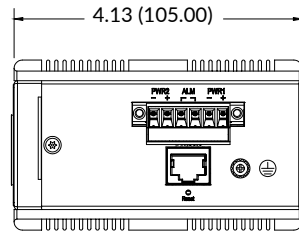

TOP

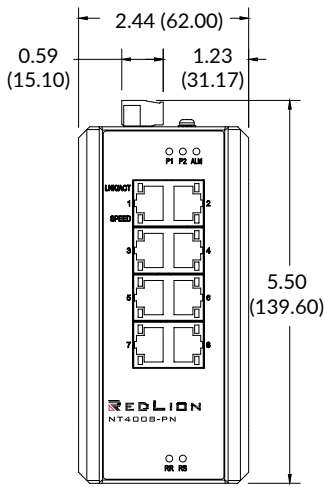

FRONT

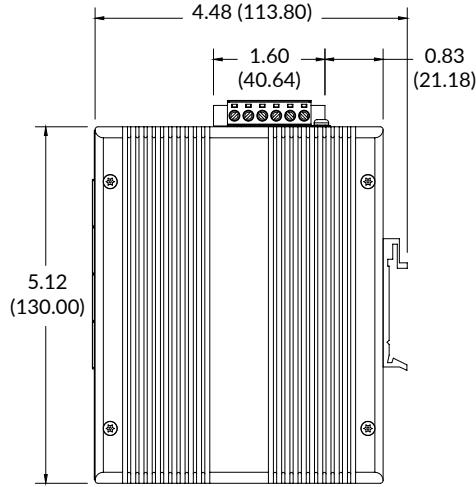

SIDE

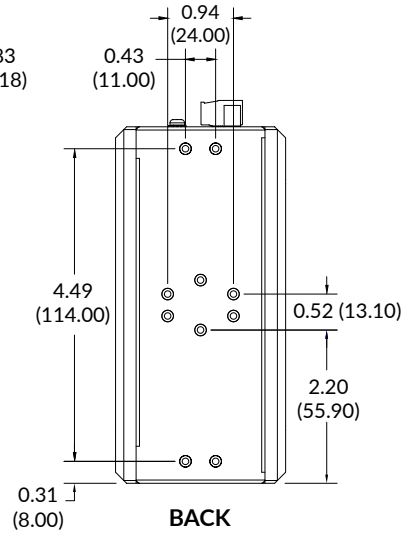

BACK

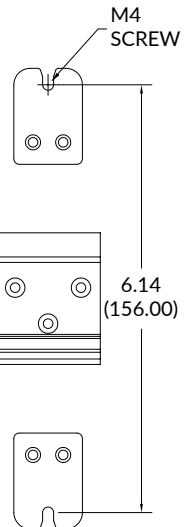

DIN RAIL/PANEL MOUNTING KIT

## NT4008-DM2-PN Specifications

CONNECTORS					
10/100/1000BaseT(X)	Six (6) RJ45 TX Copper Ports				
100BaseFX SFP Port	Up to two (2) LC SFP Fiber Transceiver Ports				
1000BaseT SFP Port	Up to two (2) RJ45 SFP Copper Transceiver Ports				
1000BaseSX/LX SFP Port	Up to two (2) LC SFP Fiber Transceiver Ports				
NETWORK MEDIA					
10BaseT	≥Cat3 cable				
100BaseTX	≥Cat5 cable				
1000BaseT	≥Cat5e cable				
100BaseFX, 1000BaseSX Multimode	50-62.5/125μm				
100BaseFXE, 1000BaseLX Singlemode	7-10/125μm				
POWER					
Power Input Options	Input Voltage Range	Steady Input Range	BTU/hr		
Redundant Input Terminals; Reverse Polarity Protection	12-58 VDC, 0.8 A	290 mA @ 24 VDC	23.75 @ 24 VDC		
ENVIRONMENTAL AND COMPLIANCES					
Operating Temperature Range	Storage Temperature Range	Humidity (non-condensing)	Operating Altitude	Operating Condition	
-40 to 75 °C	-40 to 85 °C	5 to 95% RH	Up to 6561 ft (2000 m)	OVC II and PD 2	
MECHANICAL					
Ingress Protection	Height	Width	Depth	Weight	Installation Options
IP30	5.12" (130.00 mm)	2.44" (62.00 mm)	4.13" (105.00 mm)	1.58 lbs (0.72 kg)	DIN rail or panel mount
RECOMMENDED MINIMUM WIRING CLEARANCE					
Front	4" (101.6 mm)				
Top	2" (50.8 mm)				



# NT4008-DM2-PN DIMENSIONS In inches (mm)

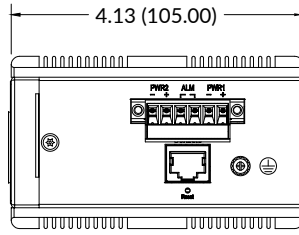

TOP

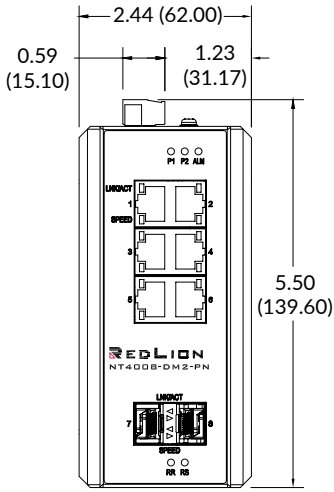

FRONT

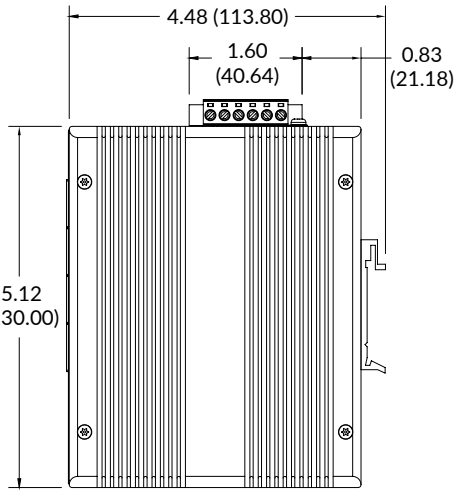

SIDE

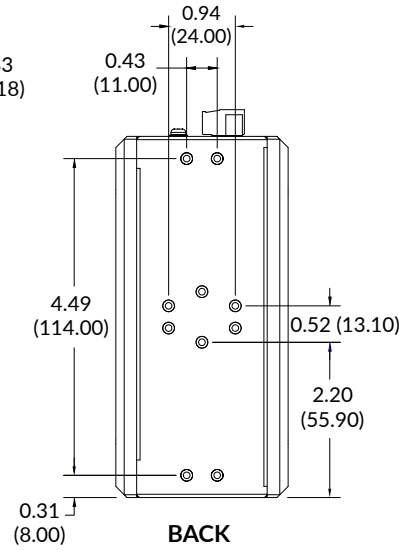

BACK

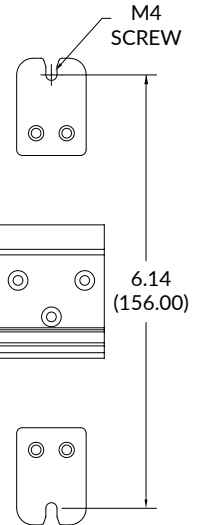

DIN RAIL/PANEL MOUNTING KIT

## LEDs

Data ports have two LEDs labeled LNK/ACT and SPEED. The LNK/ACT LED indicates link and activity status and the SPEED LED indicates port speed.

The table below describes the operating modes:

SYSTEM STATUS INDICATORS		
LED NAME	INDICATOR/COLOR	CONDITION
P1	On/Green	P1 power line has power
	Off	P1 power line is disconnected or does not have power
P2	On/Green	P2 power line has power
	Off	P2 power line is disconnected or does not have power
Alarm	On/Red	Alarm event
	Off	No alarm
RR (Ring Role)	On/Green	One of 3 Ring groups is enabled and is in the Master role
	Off	Ring is in the slave role
RS (Ring Status)	On/Green	Ring failure occurs and is detected
	Off	No ring failure detected
PORT STATUS INDICATORS		
LED NAME	INDICATOR/COLOR	CONDITION
RJ45 Port Link/Act	On/Green	Ethernet link is up but no traffic is detected
	Flashing/Green	Ethernet link is up and there is traffic detected
	Off	Ethernet link is down
RJ45 Port Speed	On/Yellow	A 1000 Mbps connection is detected
	Off	No link detected or a 10 Mbps, 100 Mbps connection is detected
SFP Port Link/Act (Ports 7 and 8) (NT4008-DM2-PN)	On/Green	Ethernet link is up
	Flashing/Green	Ethernet link is up and there is traffic detected
	Off	Ethernet link is down
SFP Speed (100/1000M) (Ports 7 and 8) (NT4008-DM2-PN)	On/Yellow	SFP port speed is 1000 Mbps
	Off	SFP port speed is 100 Mbps or link down

## Transceiver Characteristics

The following tables detail the SFP fiber transceivers that are sold separately.

### 100Base SFP Fiber Transceiver Characteristics

<b>Fiber Mode</b>	MM	SM	SM	SM
<b>Fiber Length*</b>	2 km	15 km	40 km	80 km
<b>TX Power Min.</b>	-19 dBm	-15 dBm	-5 dBm	-5 dBm
<b>RX Sensitivity Max.</b>	-31 dBm	-34 dBm	-34 dBm	-34 dBm
<b>Wavelength</b>	1310 nm	1310 nm	1310 nm	1550 nm
<b>Laser Type</b>	FP	FP	FP	DFB

### Gigabit SFP Fiber Transceiver Characteristics

<b>Fiber Mode</b>	MM	SM	SM	SM
<b>Fiber Length*</b>	550m @ 50/125 $\mu$ m 275m @ 62.5/125 $\mu$ m	10 km	40 km	80 km
<b>TX Power Min.</b>	-9.5 dBm	-9.5 dBm	-2 dBm	0 dBm
<b>RX Sensitivity Max.</b>	-17 dBm	-20 dBm	-22 dBm	-24 dBm
<b>Wavelength</b>	850 nm	1310 nm	1310 nm	1550 nm
<b>Laser Type</b>	VCSEL	FP	DFB	DFB

\* Fiber Length distances represent typical performance. Link budgets should be evaluated based on specific application conditions.



# Chapter 2 Installation

## Contents of Package

Carefully remove the switch and accessories from the shipping container and inspect them for damage. Contact Red Lion immediately if any damage is discovered.

Please verify that the box contains the following items:

- (1) DIN rail mount Ethernet switch
- (1) DIN rail mount clip
- (2) Panel mount plates
- (4) M4 screws (for panel mount plates and DIN rail clip)
- (1) DC power terminal block
- (1) Console cable
- (1) Documentation CD
- (4) RJ45 dust covers (NT4008-PN)
- (3) RJ45 and (2) SFP dust covers (NT4008-DM2-PN)

## Mounting the NT4008 Unit

A clearance of one inch should be observed on the sides, back, top and bottom to allow proper ventilation. Also, the NT4008-PN requires a cable bend radius of two inches to be observed for the front and top side of the unit. The NT4008-DM2-PN requires a cable bend radius of four inches to be observed for the front and two inches to be observed for the top side of the unit.

For hazardous location installation, the following shall be taken into consideration:

- The equipment shall only be used in an area of at least pollution degree 2, as defined in EN 60664-1.
- The equipment shall be installed in an enclosure that provides a minimum ingress protection of IP54 in accordance with EN 60079-0. The enclosure shall be accessible only with the use of a tool.

## DIN Rail Mounting Instructions

1. Screw the rugged DIN rail bracket on with the bracket and screws in the accessory kit. Tighten screws with 4.3-5.2 in-lb.

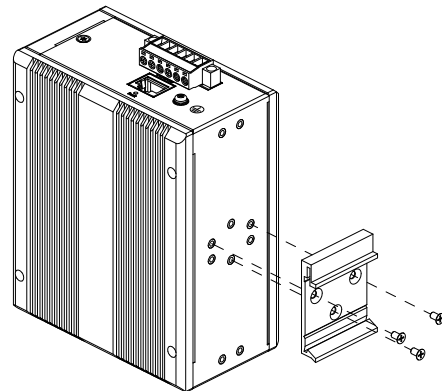

2. Hook the top of the DIN rail clip on the back of the switch to the rail.
3. Then, gently rotate the front of the switch downward, towards the panel.
4. Push the bottom of the switch towards the rail until it locks into place.
5. Apply upward force to verify the switch is securely installed.
6. Connect any communications cables to the switch.
7. Install the power and ground wires.
8. Apply power to the power supply.

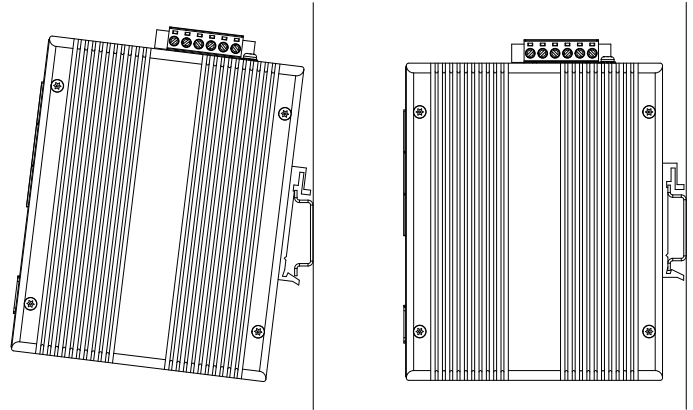



### DIN Rail Removal Instructions

1. Ensure power from the power source is off.
2. Disconnect power and ground wires.
3. Disconnect any communications cables from the unit.
4. Push the whole unit down to free the bottom of the DIN rail clip.
5. Pull the bottom of the unit away from the DIN rail.
6. Unhook the top of the unit and remove it from the DIN rail.

### Panel Mounting NT4008 Models

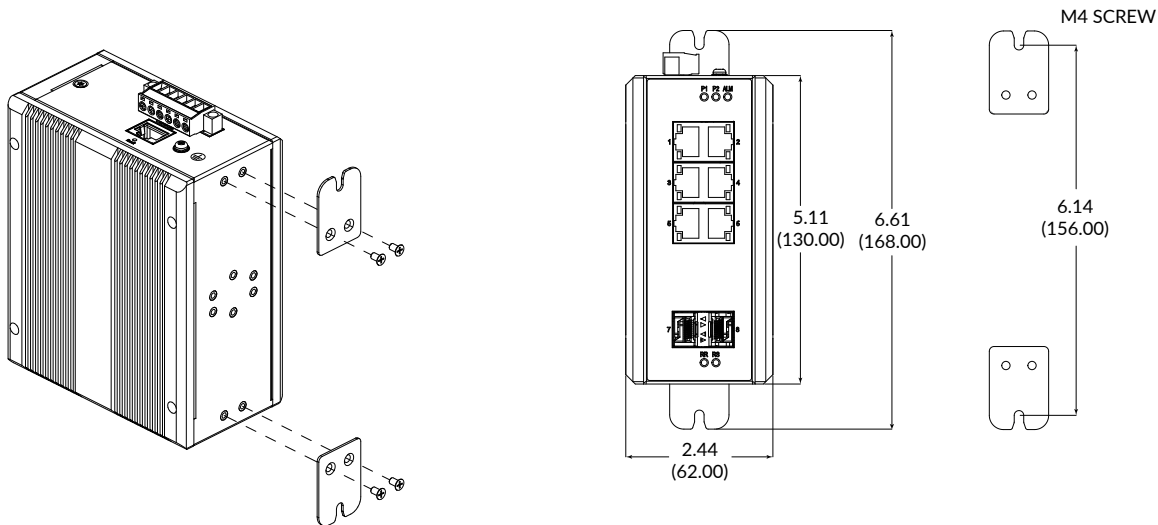
The NT4008 models are also designed for panel mounting or within an enclosure and are IP30-rated. This section includes the mechanical dimensions and drill hole placements to consider when panel mounting the unit.





**WARNING:** Panel mounting installation in non-hazardous locations only.

**AVERTISSEMENT:** Installation de montage sur panneau dans des endroits non dangereux uniquement.

## Power Source

The switch can be powered from two UL61010-2-201 certified SELV power supplies (input range 12 to 58 VDC). Unscrew and remove the DC voltage input plug from the power input header. Insert the positive and negative wires (AWG 12-20) into V+ and V- contact on the terminal block and tighten the wire-clamp screws. Tighten the wire-clamp screws with a torque value of 1.7 inch-lbs to prevent the wires from being loosened. Verify that the power LED is on.

**Note:** The DC power should be connected to a well-fused power supply. Use 20AWG-12AWG wire and screw torque value 0.5 Nm for power connection.

**Remarque:** L'alimentation en courant continu doit être connectée à une alimentation bien protégée. Utilisez un fil de 20AWG-12AWG et couple de serrage des vis 0,5 Nm pour le raccordement électrique.

**Note:** Use with Copper Conductors Only.

**Remarque:** Utiliser uniquement avec des conducteurs en cuivre.

**Note:** Cable temperature rating is at least 90 degrees or more.

**Remarque:** La température nominale du câble est d'au moins 90 degrés ou plus.

**Note:** The stripping length of the power cable is recommended to be 8-9 mm.

**Remarque:** il est recommandé de dénuder le câble d'alimentation sur une longueur de 8 à 9 mm.

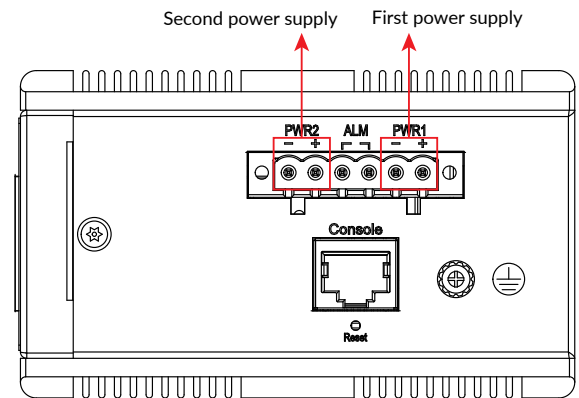

 **WARNING:** Ensure that all power sources to the chassis (power distribution panel) are turned off during the connection.

**AVERTISSEMENT:** Assurez-vous que toutes les sources d'alimentation du châssis (panneau de distribution électrique) sont éteintes pendant la connexion.

**Note:** When a DC power supply is installed, only one power supply must be connected to power for minimal operation. For redundant power operation, PWR1 and PWR2 inputs must be connected to separate DC voltage sources. This unit will draw power from the supply with higher voltage. Use 20AWG-12AWG gauge wire when connecting to the power supply.

Recommended 24 VDC power supply, similar to Red Lion's P/N NTPS-24-1-3.

Verify that the proper input voltage is connected to the NT4008 before powering on the unit. **Applying AC power to a DC NT4008 unit will damage the unit.**

**Note:** LEDs are described in detail in "LEDs" on page 14.

## Connecting to Earth Ground

The grounding of any control system is an integral part of the design. The optimum noise immunity and emissions are obtained when the NT4008 chassis is connected to earth ground via a 12 gauge wire or better. The NT4008 units provide a grounding lug (see illustration) that is used to provide a safe grounding path of the device. Torque the screw to 0.5 Nm for grounding connection. Do not over-tighten the screw.

**Note:** The NT4008 power input (V-) pins are isolated from chassis ground. Do not attempt to ground the switch to earth ground via the power input pins (V-).

**Remarque:** La NT4008 puissance d'entrée (V-) broches sont isolés de la masse du châssis. Ne pas essayer pour mettre le commutateur à la terre via les broches d'entrée d'alimentation (V-).

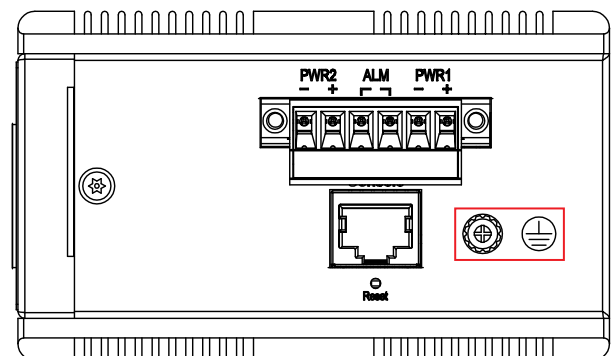

**Note:** Use with Copper Conductors Only.

**Remarque:** Utiliser uniquement avec des conducteurs en cuivre.

**Note:** The stripping length of the grounding cable is recommended to be 8-9 mm.

**Remarque:** il est recommandé de dénuder le câble de mise à la terre sur une longueur de 8 à 9 mm.

## Configurable Alarm Relay Contact

The alarm relay contact, located on the top of the NT4008, can be used to control an external warning device based on an event. The current carrying capacity is 1 A at 24 VDC. It is normally open and the relay closes when a fault condition occurs, though this can be reversed via configuration. These pins can be used to connect an external warning device such as a light in order to provide an external alarm. The conditions for generating a fault condition (closing the relay) can be configured through software.

Refer to the NT4008 Software Guide for more information.

**Note:** Use with Copper Conductors Only.

**Remarque:** Utiliser uniquement avec des conducteurs en cuivre.

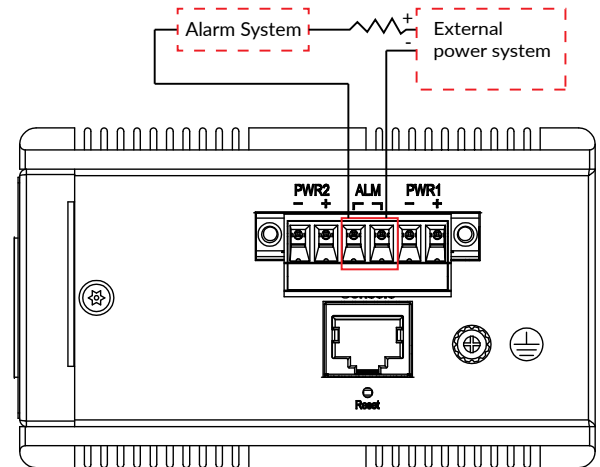

## Connecting to the Ethernet Port (RJ45 Ethernet)

For 10/100/1000BaseT(X) ports, plug a Category 5e twisted pair cable into the RJ45 connector. Connect the other end to the far end station. Verify that the LNK LEDs are ON once the connection has been completed. To connect any port to another device, use a standard Cat5 straight through or crossover cable with a minimum length of one meter and a maximum length of 100 meters.

Red Lion recommends the use of pre-manufactured Cat5e cables to ensure the best performance. If this is not an option and users must terminate their own ends on the Cat5e cables, one of the two color coded standards shown to the right should be utilized. If a user does not follow one of these standards, then the performance and maximum cable distance will be reduced significantly and may prevent the switch from establishing a link.

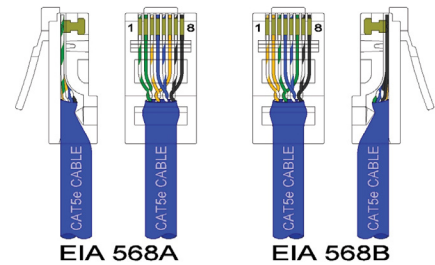

PIN #	ASSIGNMENT
1,2	T/RxA+,T/RxA-
3,6	T/RxB+,T/RxB-
4,5	T/RxC+,T/RxC-
7,8	T/RxD+,T/RxD-



**WARNING:** Creating a network loop without employing a network path protocol such as RSTP is an illegal operation that can create a network storm which will crash the network.

**AVERTISSEMENT:** La création d'un réseau sans boucle employant un chemin réseau protocole tels que RSTP est une opération illégale que peut créer une tempête du réseau qui va planter le réseau.





## Connecting to the Ethernet Port (Fiber, SFP)

For available 100 or 1000 Mbps fiber ports, use the mini-GBIC SFP. These accept plug-in fiber transceivers that typically have an LC style connector.

The connectors are available with multimode, singlemode, long-haul or special-application transceivers.

The Optical Transceiver must use a UL Certificated Class 1 laser product that shall comply with CDRH 21CFR 1040.10 and 1040.11.

	<b>DANGER:</b> Never attempt to view optical connectors that might be emitting laser energy. Do not power up the laser product without connecting the laser to the optical fiber and putting the cover in position, as laser outputs will emit infrared laser light at this point.
	<b>AVERTISSEMENT:</b> N'essayez jamais de voir des connecteurs optiques susceptibles d'émettre de l'énergie laser. Ne mettez pas le produit laser sous tension sans connecter le laser à la fibre optique et mettre le capot en place, car les sorties laser émettent une lumière laser infrarouge à ce stade.

## Console Connection

The NT4008 switches provide a console interface accessed via the console connector labeled as “Console” on the top of the NT4008 units. The console connection is used for local management through a terminal emulator or a computer with terminal emulation software.

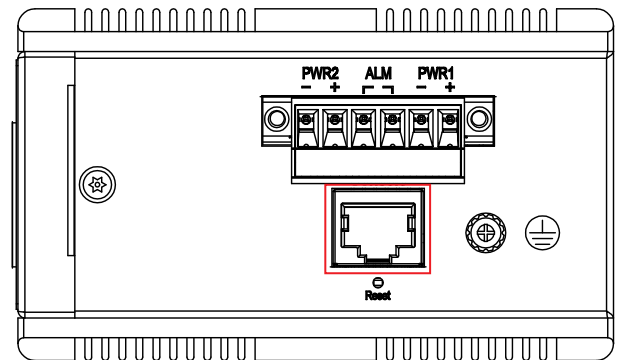

To connect the host PC to the console port, an RJ45 (male) connector to RS232 DB9 (female) connector cable is required. The RJ45 cable is connected to the CID port of the switch. The DB9 cable is connected to the PC COM port. The pin assignment of the console cable is shown to the right:

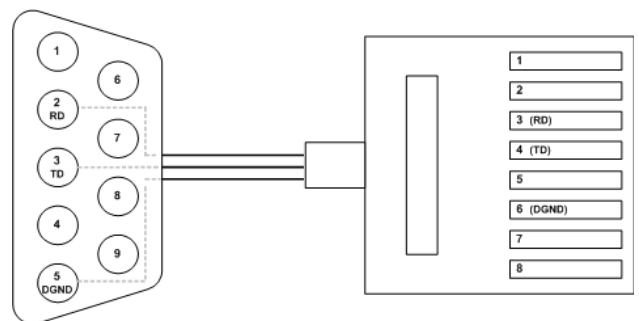

## Terminal

The following configuration should be used in HyperTerminal:

- DB9 connector to connect to computer COM port
- Port Settings: 115200 bps
- Data Bits: 8

- Parity: None
- Stop Bits: 1
- Flow Control: None



**WARNING:** The console connection is for temporary connection only. Do not use, connect, or disconnect unless the area is known to be non-hazardous. Connection or disconnection in an explosive atmosphere could result in an explosion.

**AVERTISSEMENT:** La connection à la console est pour la connexion temporaire seulement. Ne pas utiliser, connecter ou déconnecter sauf si la zone est connue pour être non dangereuse. Connexion ou la déconnexion dans une atmosphère explosive pourrait entraîner une explosion.

## Cleaning

Clean only with a damp cloth. Excess moisture or harsh chemicals can cause damage to the unit.

# Chapter 3 Accessing the Web Software Interface

1. Launch a web browser and enter the IP address of the device into the address bar. The DHCP Client is enabled by default by entering 192.168.1.201 as the fallback address.
2. The following login screen will appear.

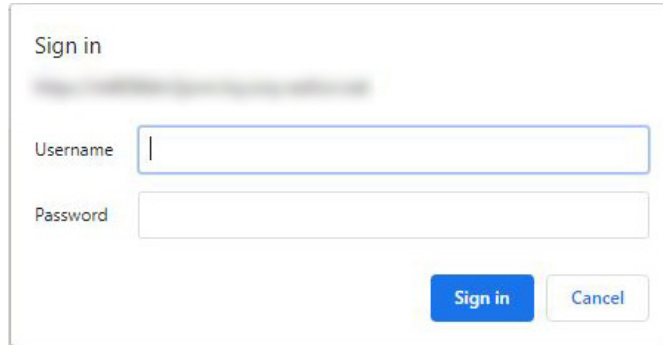

3. For the Username, enter: **admin** (all lowercase).
4. For the Password, enter: **admin** (all lowercase).  
**Note:** For security purposes, on first logon the password must be changed. The user will be prompted with the change. Canceling the change will not allow access to the device.
5. Upon successfully logging in, depending on the unit used, a screen similar to the one below will appear:



Please consult the NT4008 Software Guide for configuration options.

## Ordering Information

PART NUMBER	DESCRIPTION
NT-4008-000-PN-C	8-port Gigabit Managed Industrial Ethernet Switch (8 10/100/1000BaseT RJ45 ports), PNIO CC-B, MRC
NT-4008-000-PN-M	8-port Gigabit Managed Industrial Ethernet Switch (8 10/100/1000BaseT RJ45 ports), PNIO CC-B, MRM
NT-4008-DM2-PN-C	8-port Gigabit Managed Industrial Ethernet Switch (6 10/100/1000BaseT RJ45 ports, 2 Dual Mode 100/1000Base SFP expansion slots), PNIO CC-B, MRC
NT-4008-DM2-PN-M	8-port Gigabit Managed Industrial Ethernet Switch (6 10/100/1000BaseT RJ45 ports, 2 Dual Mode 100/1000Base SFP expansion slots), PNIO CC-B, MRM

## Accessories

PART NUMBER	DESCRIPTION
NTSFP-FX	100BaseFX Multimode Fiber SFP Transceiver (LC Style Connector, 2km)
NTSFP-FXE-15	100BaseFX Singlemode Fiber SFP Transceiver (LC Style Connector, 15km)
NTSFP-FXE-40	100BaseFX Singlemode Fiber SFP Transceiver (LC Style Connector, 40km)
NTSFP-FXE-80	100BaseFX Singlemode Fiber SFP Transceiver (LC Style Connector, 80km)
NTSFP-LX-10	1000BaseLX Singlemode Fiber SFP Transceiver (LC Style Connector, 10km)
NTSFP-LX-40	1000BaseLX Singlemode Fiber SFP Transceiver (LC Style Connector, 40km)
NTSFP-LX-80	1000BaseLX Singlemode Fiber SFP Transceiver (LC Style Connector, 80km)
NTSFP-SX	1000BaseSX Multimode Fiber SFP Transceiver (LC Style Connector, 550m)
NTSFP-TX	1000BaseT Copper SFP Transceiver (RJ45 Connector)
NTPS-24-1-3	DIN Rail Power Supply, 1.3 Amp @ 24 VDC

# Service and Support Information

## Service Information

We sincerely hope that you never experience a problem with any of our products. If you do need service, call Red Lion at 1-877-432-9908 for Technical Support. A trained specialist will help you determine the source of the problem. Many problems are easily resolved with a single phone call. If it is necessary to return a unit to us, an RO (Repair Order) can be obtained on the Red Lion website.

Red Lion tracks the flow of returned material with our RO system to ensure speedy service. You must include this RO number on the outside of the box so that your return can be processed immediately.

Be sure to have your original purchase order number and date purchased available.

We suggest that you give us a repair purchase order number in case the repair is not covered under our warranty. You will not be billed if the repair is covered under warranty.

Please supply us with as many details about the problem as you can. The information you supply will be written on the RO form and supplied to the repair department before your unit arrives. This helps us to provide you with the best service, in the fastest manner. Repairs are completed as soon as possible. If you need a quicker turnaround, ship the unit to us by air freight. We give priority service to equipment that arrives by overnight delivery.

We apologize for any inconvenience that the need for repair may cause you. We hope that our rapid service meets your needs. If you have any suggestions to help us improve our service, please give us a call. We appreciate your ideas and will respond to them.

## For Your Convenience:

Please fill in the following and keep this manual with your Red Lion system for future reference.

P.O. #: \_\_\_\_\_ Date Purchased: \_\_\_\_\_  
Purchased From: \_\_\_\_\_  
Serial Number: \_\_\_\_\_

## Product Support

### Technical Support:

Inside US: +1 (877) 432-9908  
Outside US: +1 (717) 767-6511  
Support: [support.redlion.net](http://support.redlion.net)  
Hours: 8:00 am to 6:00 pm EST

Red Lion Controls  
20 Willow Springs Circle  
York, PA 17406  
Website: [www.redlion.net](http://www.redlion.net)

## LIMITED WARRANTY

(a) Red Lion Controls Inc. (the "Company") warrants that all Products shall be free from defects in material and workmanship under normal use for the period of time provided in "Statement of Warranty Periods" (available at [www.redlion.net](http://www.redlion.net)) current at the time of shipment of the Products (the "Warranty Period"). **EXCEPT FOR THE ABOVE-STATED WARRANTY, COMPANY MAKES NO WARRANTY WHATSOEVER WITH RESPECT TO THE PRODUCTS, INCLUDING ANY (A) WARRANTY OF MERCHANTABILITY; (B) WARRANTY OF FITNESS FOR A PARTICULAR PURPOSE; OR (C) WARRANTY AGAINST INFRINGEMENT OF INTELLECTUAL PROPERTY RIGHTS OF A THIRD PARTY; WHETHER EXPRESS OR IMPLIED BY LAW, COURSE OF DEALING, COURSE OF PERFORMANCE, USAGE OF TRADE OR OTHERWISE.** Customer shall be responsible for determining that a Product is suitable for Customer's use and that such use complies with any applicable local, state or federal law.

(b) The Company shall not be liable for a breach of the warranty set forth in paragraph (a) if (i) the defect is a result of Customer's failure to store, install, commission or maintain the Product according to specifications; (ii) Customer alters or repairs such Product without the prior written consent of Company.

(c) Subject to paragraph (b), with respect to any such Product during the Warranty Period, Company shall, in its sole discretion, either (i) repair or replace the Product; or (ii) credit or refund the price of Product provided that, if Company so requests, Customer shall, at Company's expense, return such Product to Company.

(d) **THE REMEDIES SET FORTH IN PARAGRAPH (c) SHALL BE THE CUSTOMER'S SOLE AND EXCLUSIVE REMEDY AND COMPANY'S ENTIRE LIABILITY FOR ANY BREACH OF THE LIMITED WARRANTY SET FORTH IN PARAGRAPH (a).**

**BY INSTALLING THIS PRODUCT, YOU AGREE TO THE TERMS OF THIS WARRANTY, AS WELL AS ALL OTHER DISCLAIMERS AND WARRANTIES IN THIS DOCUMENT.**